

**HONDA**



The Power of Dreams

*All New*  
**CITY**



**HONDA**

As you read this manual, you will find Information that is preceded by a symbol **NOTICE**. This information is intended to help you avoid damage to your vehicle, other property, or the environment.

Symbols   on labels attached to your vehicle are to remind you to read this owner's manual for proper and safe operation of your vehicle.

 is colour-coded to indicate "danger" (red), "warning" (orange), or "caution" (amber).

 **Safety Labels** P. 85

## A Few Words About Safety

---

Your safety, and the safety of others, is very important. And operating this vehicle safely is an important responsibility.

To help you make informed decisions about safety, we have provided operating procedures and other information on labels and in this manual. This information alerts you to potential hazards that could hurt you or others.

Of course, it is not practical or possible to warn you about all the hazards associated with operating or maintaining your vehicle. You must use your own good judgement.

You will find this important safety information in a variety of forms, including:

- **Safety Labels** - on the vehicle.
- **Safety Messages** - preceded by a safety alert symbol  and one of three signal words: **DANGER**, **WARNING**, or **CAUTION**. These signal words mean:

 **DANGER**

You WILL be KILLED or SERIOUSLY HURT if you don't follow instructions.

 **WARNING**

You CAN be KILLED or SERIOUSLY HURT if you don't follow instructions.

 **CAUTION**

You CAN be HURT if you don't follow instructions.

- **Safety Headings** - such as Important Safety Precautions.
- **Safety Section** - such as Safe Driving.
- **Instructions** - how to use this vehicle correctly and safely.

This entire book is filled with important safety information - please read it carefully.

## **Event Data Recorders**

Your vehicle is equipped with several devices commonly referred to as Event Data Recorders. They record various types of real time vehicle data such as SRS airbag deployment and SRS system components failure.

This data belongs to the vehicle owner and may not be accessed by anyone else except as legally required or with the permission of the vehicle owner.

However this data may be accessed by Honda, its authorised dealers and authorised repairers, employees, representatives and contractors only for the purpose of the technical diagnosis, research and development of the vehicle.

## **Service Diagnostic Recorders**

Your vehicle is equipped with service-related devices that record information about powertrain performance and driving conditions. The data can be used to help technicians diagnose, repair and maintain the vehicle. This data may not be accessed by anyone else except as legally required or with the permission of the vehicle owner.

However this data may be accessed by Honda, its authorised dealers and authorised repairers, employees, representatives and contractors only for the purpose of the technical diagnosis, research and development of the vehicle.

This owner's manual should be considered a permanent part of the vehicle and should remain with the vehicle when it is sold.

This owner's manual covers all models of your vehicle. You may find descriptions of equipment and features that are not on your particular model.

Images throughout this owner's manual represent features and equipment that are available on some, but not all, models. Your particular model may not have some of these features.

The information and specifications included in this publication were in effect at the time of approval for printing. Honda Cars India Ltd. reserves the right, however, to discontinue or change specifications or design at any time without notice and without incurring any obligation.

## ➤ Safe Driving P. 27

For Safe Driving P. 28      Seat Belts P. 33      Airbags P. 44

## ➤ Instrument Panel P. 87

Indicators P. 88      Gauges and Displays P. 104

## ➤ Controls P. 123

Lock P. 124      Locking and Unlocking the Doors P. 126  
Windows P. 151      Sunroof\* P. 155  
Seats P. 175  
Climate Control System\* P. 194

## ➤ Features P. 199

## ➤ Driving P. 201

Before Driving P. 202      Towing a Trailer P. 205      When Driving P. 206  
Fuel Economy and CO<sub>2</sub> Emissions P. 249

## ➤ Maintenance P. 251

Before Performing Maintenance P. 252      Maintenance Schedule P. 255  
Replacing Light Bulbs P. 280  
Battery P. 303      Remote Transmitter Care P. 306  
Accessories and Modifications P. 314

## ➤ Handling the Unexpected P. 317

Tools P. 318      If a Tyre Goes Flat P. 319  
Overheating P. 338      Indicator, Coming On/Blinking P. 340

## ➤ Information P. 363

Specifications P. 364      Identification Numbers P. 368

# Contents

Child Safety P. 54

Exhaust Gas Hazard P. 84

Safety Labels P. 85

Opening and Closing the Boot P. 146

Operating the Switches Around the Steering Wheel P. 157

Interior Convenience Items P. 183

Security System P. 149

Mirrors P. 172

Cooling System\* P. 191

Braking P. 235

Parking Your Vehicle P. 240

Refueling P. 246

Maintenance Under the Bonnet P. 263

Checking and Maintaining Wiper Blades P. 294

Cooling System\*/Climate Control System\* Maintenance P. 307

Diesel Particulate Filter (DPF) Regeneration\* P. 277

Checking and Maintaining Tyres P. 296

Cleaning P. 309

Engine Does Not Start P. 329

Fuses P. 348

Jump Starting P. 333

Emergency Towing P. 362

Shift Lever Does Not Move P. 337

Devices that Emit Radio Waves\* P. 370

Quick Reference Guide P. 4

Safe Driving P. 27

Instrument Panel P. 87

Controls P. 123

Features P. 199

Driving P. 201

Maintenance P. 251

Handling the Unexpected P. 317

Information P. 363

Index P. 372

# Visual Index

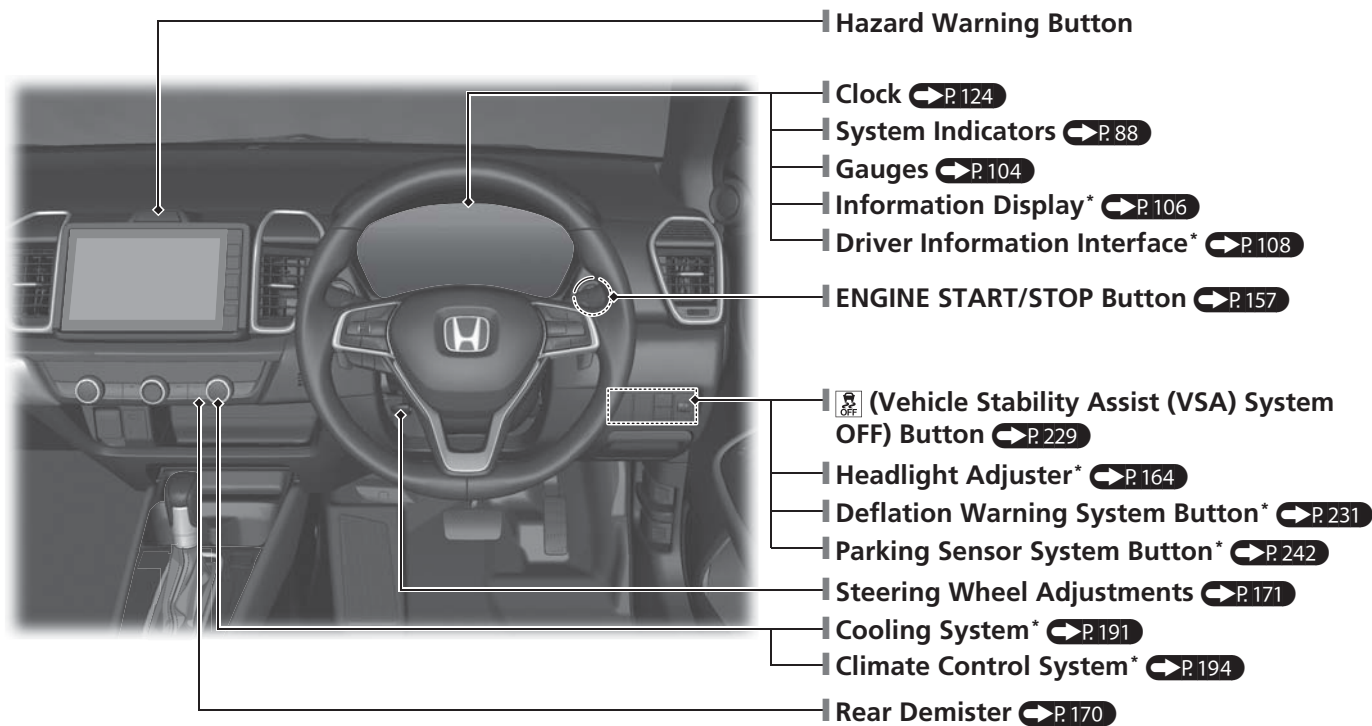

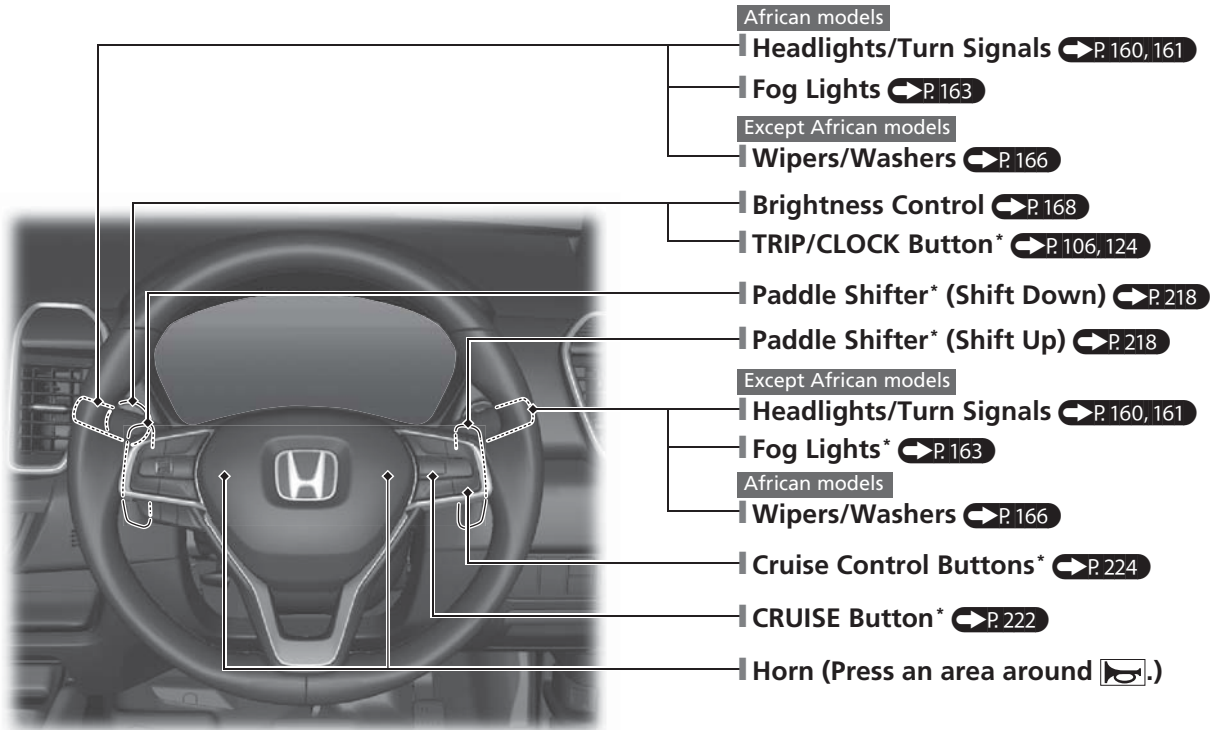

# Visual Index

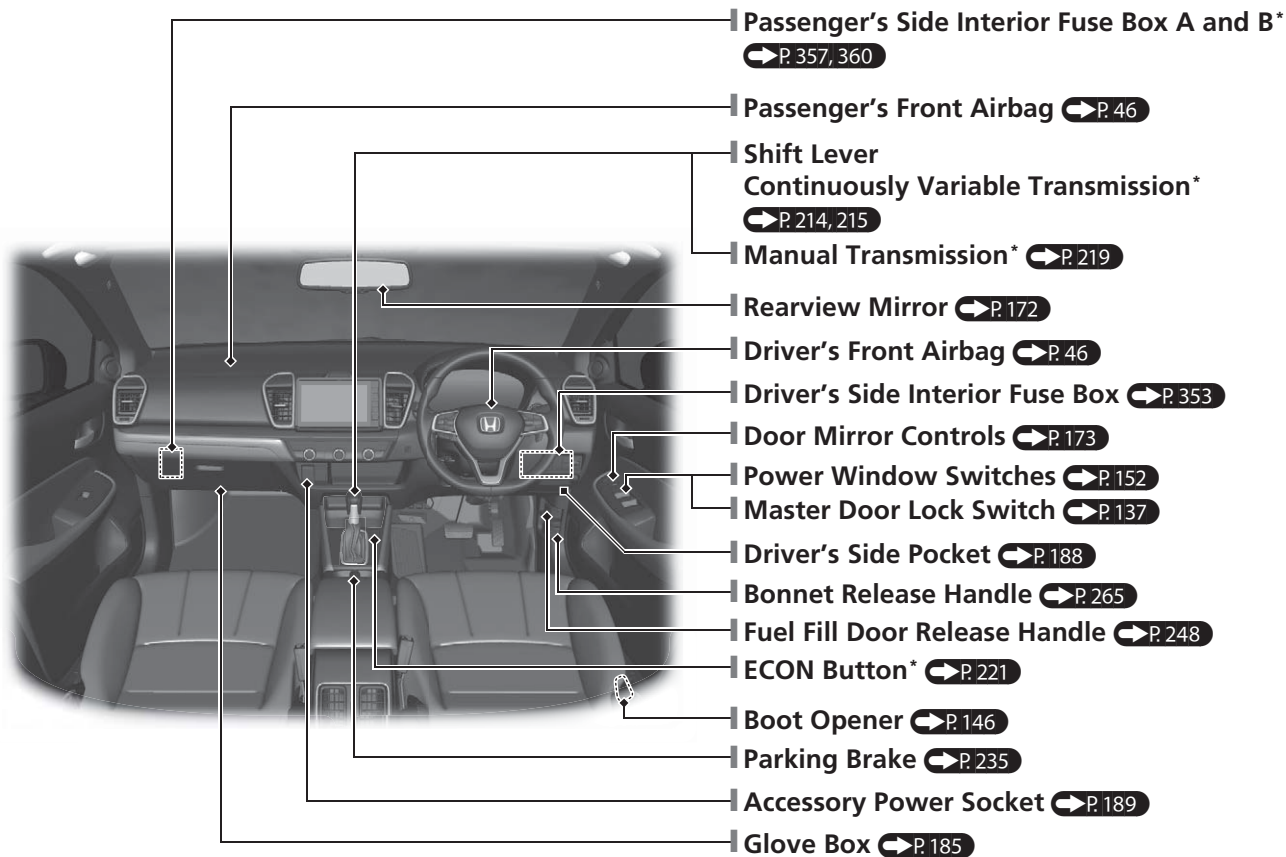



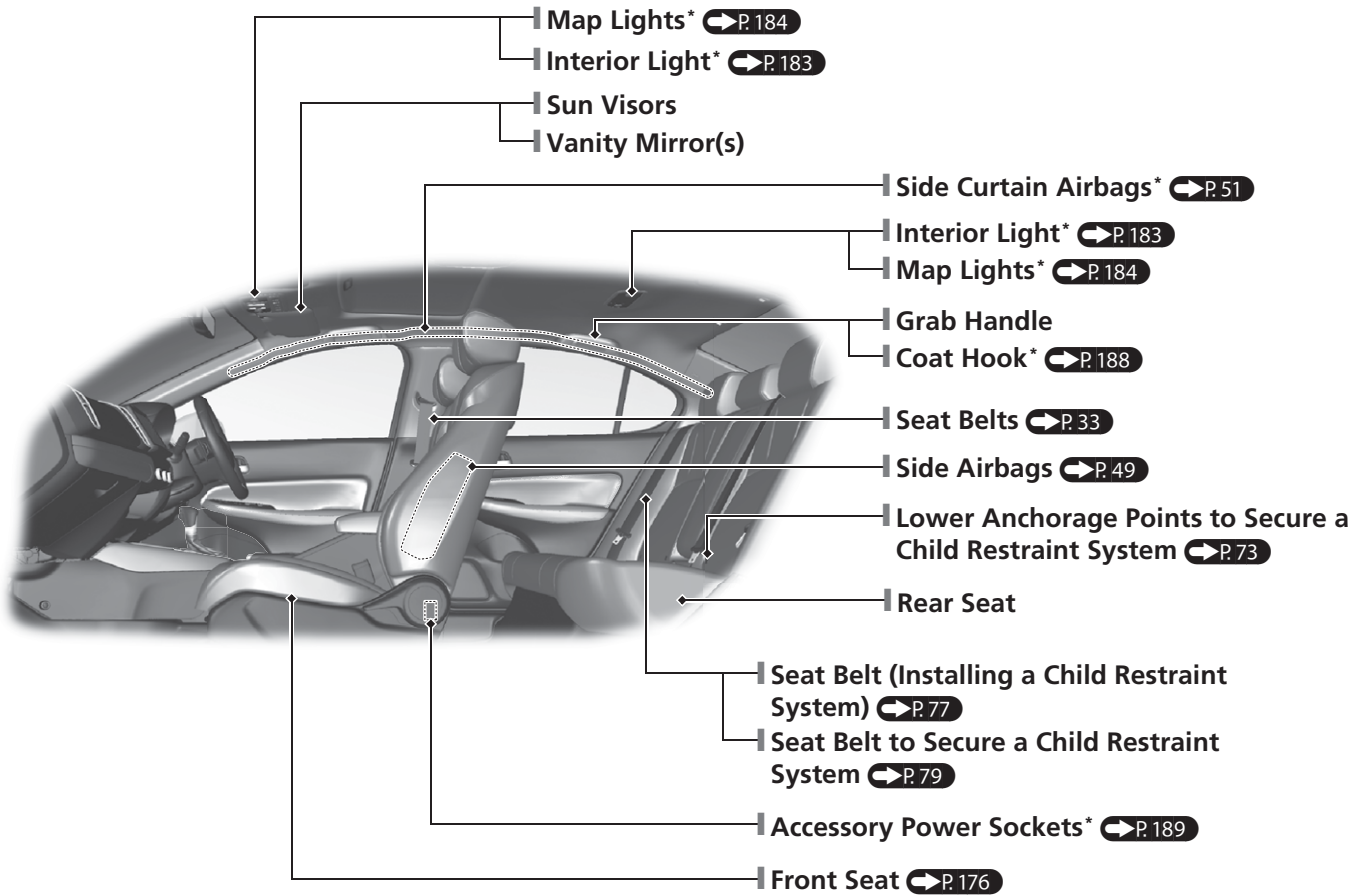

# Visual Index

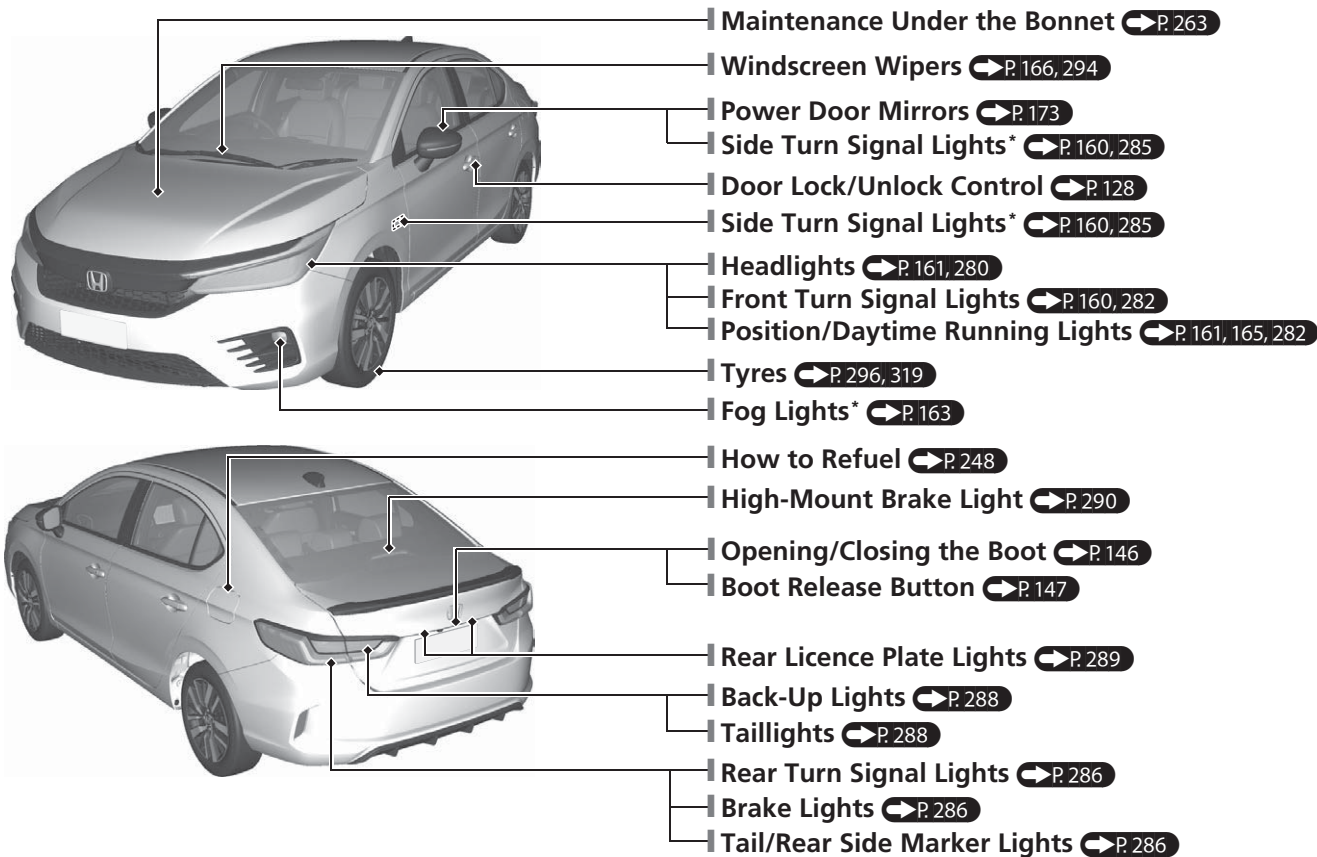

# Eco Assist System\*

## Ambient Meter

- The colour of the ambient meter changes to green to indicate that the vehicle is being driven in a fuel efficient manner.

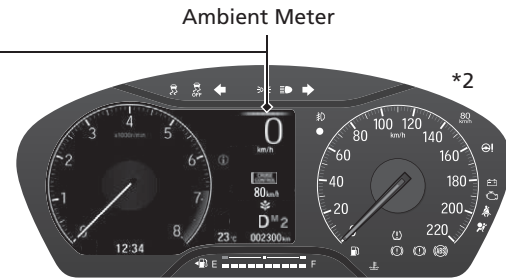
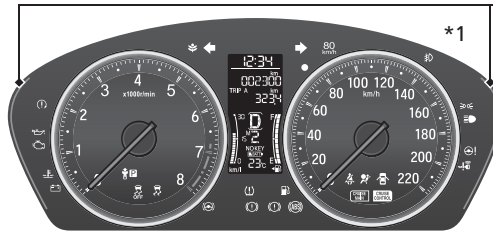

**ECON Mode Indicator**  P. 98  
Comes on when the ECON button is pressed.

\*1



\*2



**ECON Button**  P. 221  
Helps to maximise fuel economy.

\*1: Models with information display  
\*2: Models with driver information interface

# Safe Driving ➔ P.27

## Before Driving Checklist ➔ P.202

- Before driving, check that the front seats, head restraints, steering wheel, and mirrors have been properly adjusted.

## Child Safety ➔ P.54

- All children 12 and younger should be seated in the rear seat.
- Small children should be properly restrained in a front-facing child restraint system.
- Infants must be properly restrained in a rear-facing child restraint system on a rear seat.

## Exhaust Gas Hazard ➔ P.84

- Your vehicle emits dangerous exhaust gases that contain carbon monoxide. Do not run the engine in confined spaces where carbon monoxide gas can accumulate.

## Seat Belts ➔ P.33

- Fasten your seat belt and sit upright well back in the seat.
- Check that your passengers are wearing their seat belts correctly.



Fasten your lap belt as low as possible.

## Airbags ➔ P.44

- Your vehicle is fitted with airbags to help to protect you and your passengers during a moderate-to-severe collision.

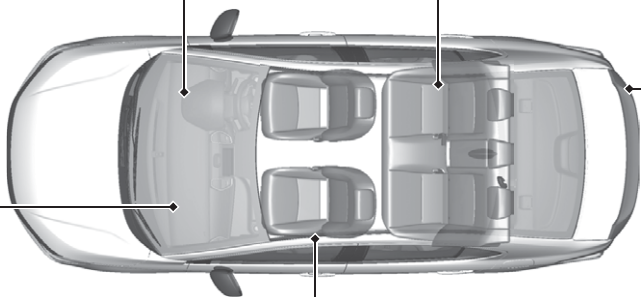

# Instrument Panel P.87

Gauges  P.104 / Information Display\*  P.106 / Driver Information Interface\*  P.108 / System Indicators  P.88

Models with information display

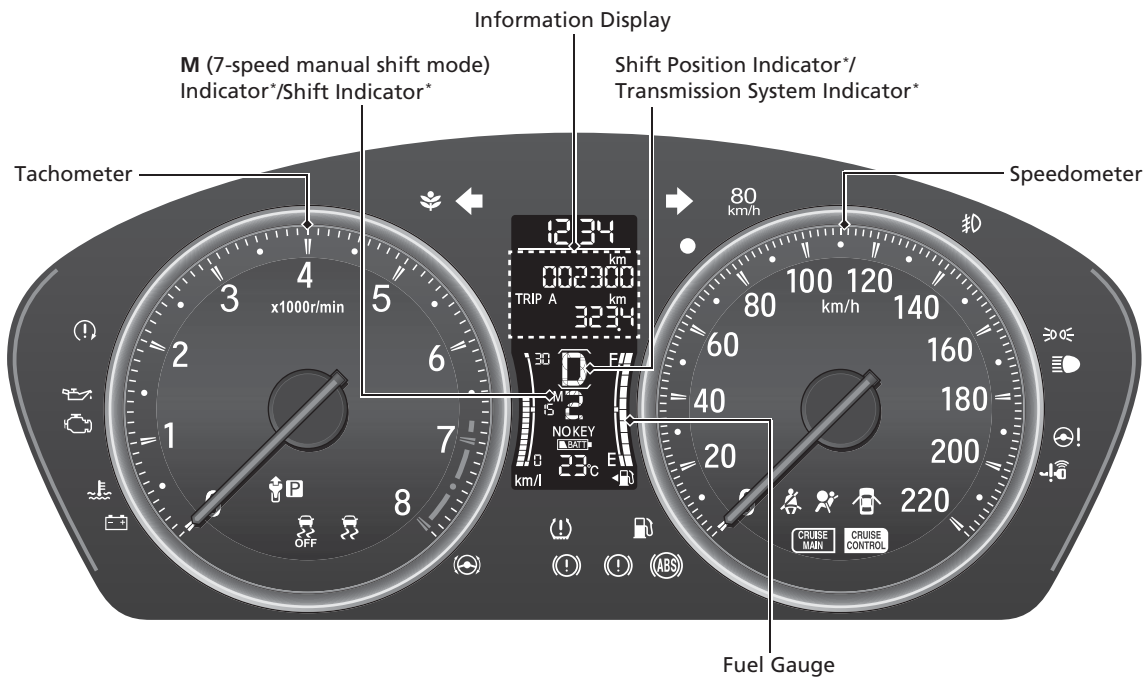

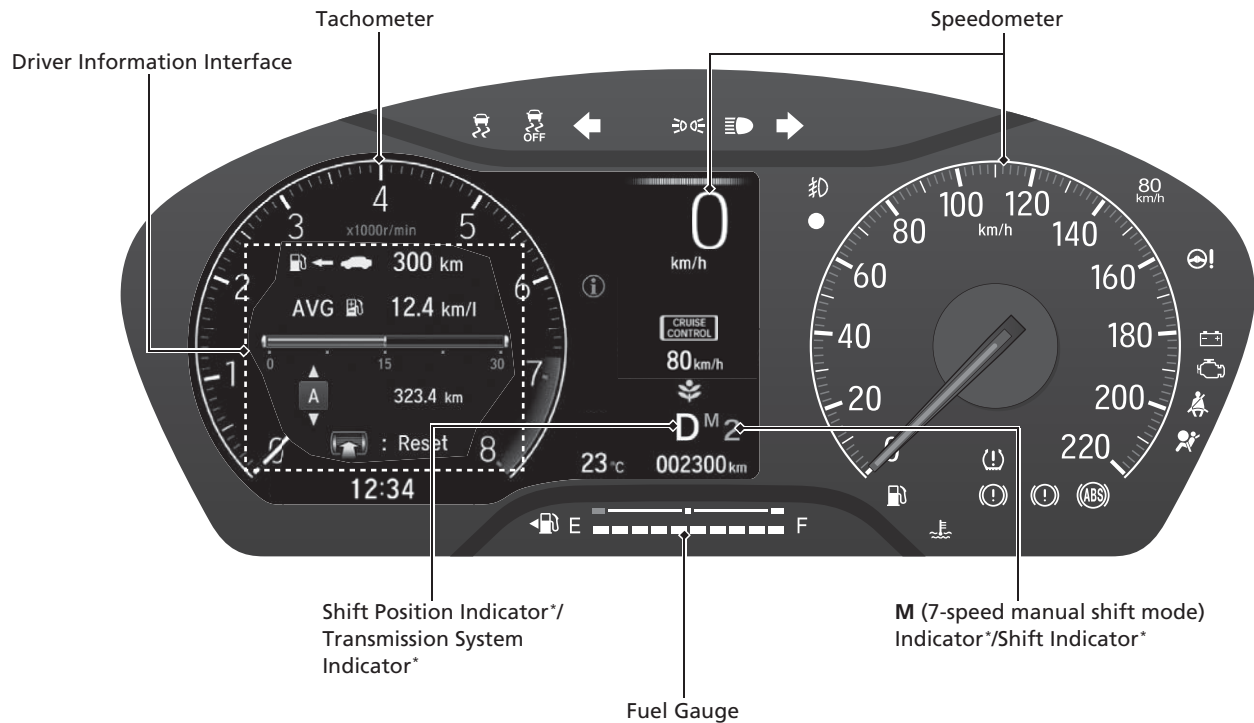

\* Not available on all models



# Controls P.123

## Clock P.124

Models with information display

You can adjust the time in the information display using the **TRIP/CLOCK**,  or  button.



Models with driver information interface

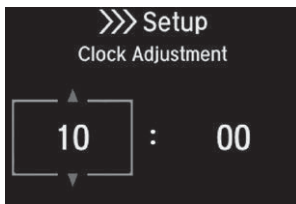

## ENGINE START/STOP Button P.157

Press the button to change the vehicle's power mode.

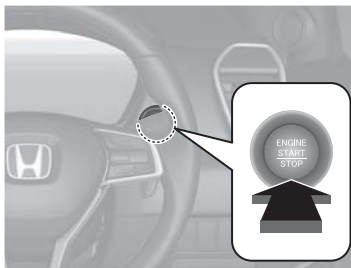

## Turn Signals P.160

Turn Signal Control Lever



## Lights P.161

### Light Control Switches

#### Models without automatic lighting control

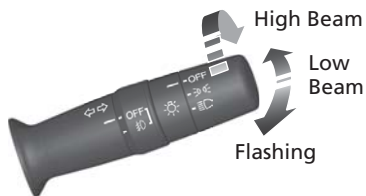

#### Models with automatic lighting control

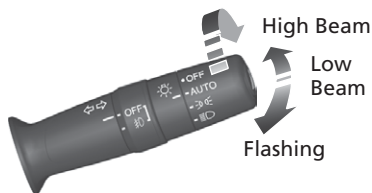

## Wipers and Washers

### P.166

### Wiper/Washer Control Lever

**MIST** —  
**OFF**  
**INT:** Low speed with intermittent  
**LO:** Low speed wipe  
**HI:** High speed wipe

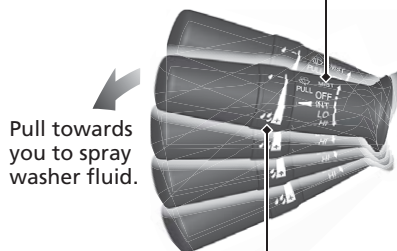

**Adjustment Ring\***  
: Lower speed, fewer sweeps  
: Higher speed, more sweeps

## Steering Wheel P.171

- To adjust, push the adjustment lever down, adjust to the desired position, then lock the lever back in place.

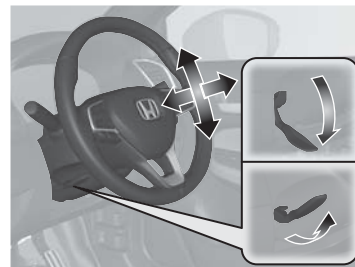

## Unlocking the Front Door from the Inside P.136

#### Except African and Latin American models

- Pull the driver's door inner handle to unlock and open it at the same time.

#### African and Latin American models

- Pull either front door inner handle to unlock and open it at the same time.

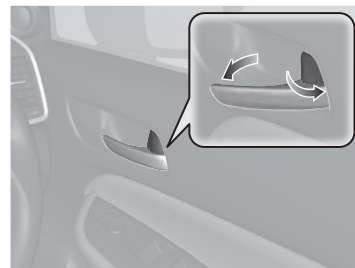



## Boot P.146

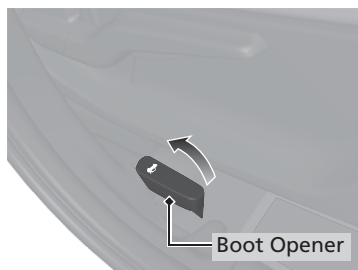

- Pull the boot opener on the outside of the driver's seat to unlock and open the boot.
- Press the boot release button on the boot lid to unlock and open the boot.
- Press the boot release button on the remote to unlock and open the boot.

## Power Door Mirrors

 P.173

- With the power mode in ON, move the selector switch to L or R.
- Push the appropriate edge of the adjustment switch to adjust the mirror.
- Press the folding button\* to fold in and out the door mirrors.

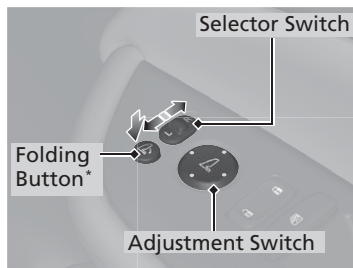





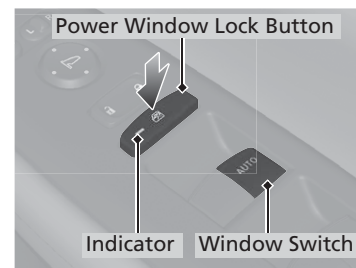





## Power Windows P.151

- With the power mode in ON, open and close the power windows.
- If the power window lock button is in the off position, each passenger's window can be opened and closed with its own switch.
- If the power window lock button is in the on position (indicator on), each passenger's window switch is disabled.





## Cooling System \* P.191



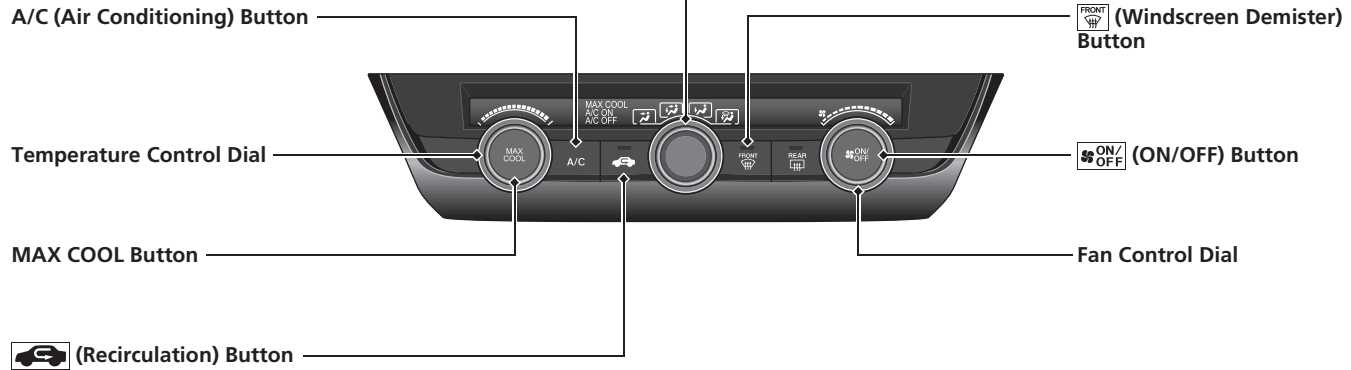

- Press the  button to turn the system on or off.
- Rotate the fan control dial to adjust the fan speed.
- Turn the mode control dial to  /  /  /  to select the vents air flows from.
- Rotate the temperature control dial to adjust the temperature.
- Press the  button to defrost the windscreen.

-  Air flows from dashboard vents and back of the console compartment.
-  Air flows from floor and dashboard vents, and back of the console compartment.
-  Air flows from floor vents.
-  Air flows from floor and windscreen demister vents.



# Climate Control System\* P. 194

- Press the **AUTO** button to activate the climate control system.
- Press the  button to turn the system on and off.
- Press the  button to defrost the windscreen.

-  Air flows from dashboard vents and back of the console compartment\*.
-  Air flows from floor and dashboard vents, and back of the console compartment\*.
-  Air flows from floor vents.
-  Air flows from floor and windscreen demister vents.

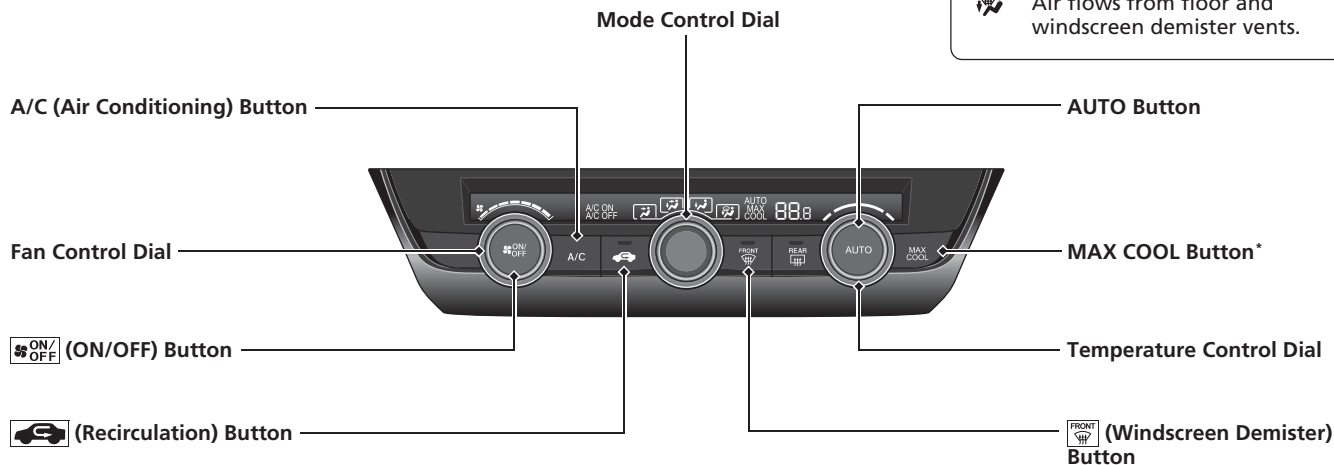

\* Not available on all models

# Driving

## Manual Transmission\*

## Continuously Variable Transmission\*



- Shift to **P** and depress the brake pedal when starting the engine.

### Shifting

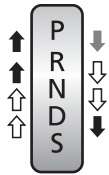

- ↓ Depress the brake pedal and press the release button to move out of **P**.
- ↕ Move the shift lever without pressing the release button.
- ↕ Press the release button to move the shift lever.



- P** **Park**
    - Turn off or start the engine.
    - Transmission is locked.
  - R** **Reverse**
    - Used when reversing.
  - N** **Neutral**
    - Transmission is not locked.
  - D** **Drive**
    - Normal driving.
    - On models with paddle shifter, 7-speed manual shift mode can be used temporarily.
- Models with paddle shifter**
- S** **Drive (S)**
    - 7-speed manual shift mode can be used.

### 7-Speed Manual Shift Mode\*

- Allows you to manually shift the transmission up or down without releasing your hands from the steering wheel.

#### When the shift lever is in **S**

- Pulling a paddle shifter changes the mode from continuously variable transmission to 7-speed manual shift mode.
- The **M** indicator and the selected speed number are displayed in the shift indicator.

#### When the shift lever is in **D**

- Pulling a paddle shifter temporarily changes the mode from continuously variable transmission to 7-speed manual shift mode. The selected speed number is displayed in the shift indicator.

#### Models with driver information interface

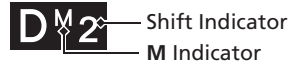

#### Models with information display

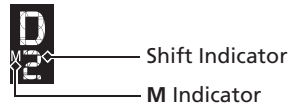

Paddle Shifter (-)      Paddle Shifter (+)

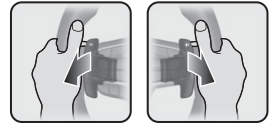

#### Models without paddle shifter

- S** **Drive (S)**
  - Better acceleration
  - Increased engine braking
  - Going up or down hills



## VSA On and Off P.229

- The Vehicle Stability Assist (VSA) system helps to stabilise the vehicle during cornering, and helps to maintain traction while accelerating on loose or slippery road surfaces.
- VSA comes on automatically every time you start the engine.
- To partially disable or fully restore VSA function, press and hold the button until you hear a beep.

## Cruise Control\* P.222

- Cruise control allows you to maintain a set speed without keeping your foot on the accelerator pedal.
- To use cruise control, press the **CRUISE** button, then press **SET/-** once you have achieved the desired speed (above 40 km/h).

## Deflation Warning System\* P.231

- Detects a change in tyre conditions and overall dimensions due to decrease in tyre pressures.
- The deflation warning system is turned on automatically every time you start the engine.
- An initialisation procedure must be performed when certain conditions arise.

# Refueling P. 246

## Petrol models

### Fuel recommendation:

#### Indonesian models

**Unleaded petrol, research octane number 90 or higher**

#### Except Indonesian models

**Unleaded petrol, research octane number 91 or higher**

**Fuel tank capacity: 40 L**

## Diesel models

### Fuel recommendation:

**Automotive Diesel Fuel**

**Fuel tank capacity: 40 L**

- 1** Pull on the fuel fill door release handle under the dashboard at the driver's side.



- 2** Turn the fuel fill cap slowly to remove the cap.

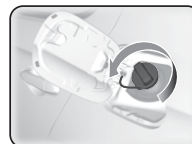

- 3** Place the cap in the holder on the fuel fill door.



- 4** After refueling, screw the cap back on until it clicks at least once.

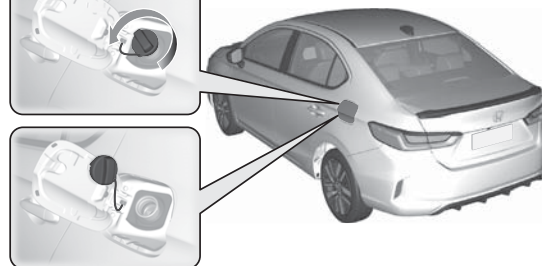

# Maintenance ↔ P. 251

## Under the Bonnet ↔ P. 263

- Check engine oil, engine coolant, and windscreen washer fluid. Add when necessary.
- Check brake/clutch\* fluid.
- Check the battery condition monthly.

- 1 Pull the bonnet release handle under the driver's side lower outside corner of the dashboard.



- 2 Locate the bonnet latch lever, pull it up, and then raise the bonnet. Once you have raised the bonnet slightly, you can release the lever.



- 3 When finished, close the bonnet and make sure it is firmly locked in place.

## Wiper Blades ↔ P. 294

- Replace blades if they leave streaks across the windscreen.



## Tyres ↔ P. 296

- Inspect tyres and wheels regularly.
- Check tyre pressures regularly.
- Install winter tyres for winter driving.

## Lights ↔ P. 280

- Inspect all lights regularly.

# Handling the Unexpected ↔ P.317

## Flat Tyre ↔ P.319

- Park in a safe place and replace the flat tyre with the spare tyre in the boot.



## Engine Won't Start ↔ P.329

- If the battery is dead, jump start using a booster battery.



## Overheating ↔ P.338

- Park in a safe location. If you do not see steam under the bonnet, open the bonnet, and let the engine cool down.



## Indicators Come On ↔ P.340

↔ P.340

- Identify the indicator and consult the owner's manual.



## Blown Fuse ↔ P.348

- Check for a blown fuse if an electrical device does not operate.

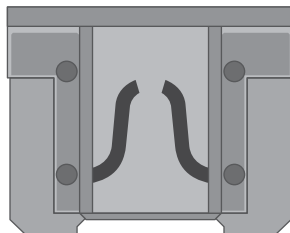

## Emergency Towing ↔ P.362

- Call a professional towing service if you need to tow your vehicle.





# What to Do If

**Q** The power mode does not change from **VEHICLE OFF (LOCK)** to **ACCESSORY**. Why?

**A**

- The steering wheel may be locked.
- Move the steering wheel left and right after pressing the **ENGINE START/STOP** button.



**Q** **Continuously variable transmission models**  
The power mode does not change from **ACCESSORY** to **VEHICLE OFF (LOCK)**. Why?

**A** The shift lever should be moved to **P**.



**Q** Why does the brake pedal pulsate slightly when applying the brakes?

**A** This can occur when the ABS activates and does not indicate a problem. Apply firm, steady pressure on the brake pedal. Never pump the brake pedal.

▶ Anti-lock Brake System (ABS) P. 237

**Q** The rear door cannot be opened from inside the vehicle. Why?

**A** Check if the childproof lock is in the lock position. If so, open the rear door with the outside door handle. To cancel this function, slide the lever up to the unlock position.

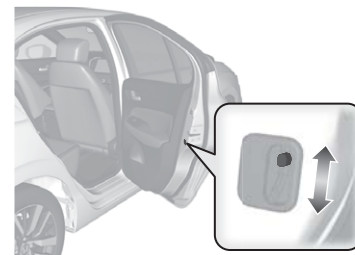

**Q** Why do the doors lock after I unlocked the doors?

**A** If you do not open the doors within 30 seconds, the doors are relocked automatically for security.

**Q** Why does the beeper sound when I open the driver's door?

**A** The beeper sounds when:

- The power mode is in ACCESSORY.
- The exterior lights are left on.

**Q** Models with driver information interface  
Why does a beeper sound when I walk away from the vehicle after I close the door?

**A** The beeper sounds if you move outside the walk away auto lock operating range before the door completely closes.

➤ Locking the doors and boot (Walk away auto lock\*) ➔ P.130

---

**Q** Why does the beeper sound when I start driving?

**A** The beeper sounds when:

- Driver and/or front passenger are not wearing their seat belts.
- The parking brake lever is not fully released.

---

**Q** **Models with deflation warning system**  
I'm seeing an amber indicator of a tyre with an exclamation point. What is that?

**A** The Deflation Warning System needs attention. If you recently inflated or changed a tyre, you have to recalibrate the system.

➤ Deflation Warning System\* ➔ P.231

---

**Q** Why do I hear a screeching sound when I apply the brake pedal?

**A** The brake pads may need to be replaced. Have your vehicle inspected by a dealer.

---



# Safe Driving

You can find many safety recommendations throughout this chapter, and throughout this manual.

## For Safe Driving

Important Safety Precautions.....	28
Your Vehicle's Safety Features.....	30
Safety Checklist .....	31

## Seat Belts

About Your Seat Belts.....	33
Fastening a Seat Belt.....	39
Seat Belt Inspection.....	42
Anchorage Points.....	43

## Airbags

Airbag System Components.....	44
Types of Airbags .....	46

Front Airbags (SRS) .....	46
Side Airbags.....	49
Side Curtain Airbags* .....	51
Airbag System Indicators.....	52
Airbag Care .....	53

## Child Safety

Protecting Child Passengers .....	54
Safety of Infants and Small Children...	58
Safety of Larger Children .....	81

## Exhaust Gas Hazard

Carbon Monoxide Gas.....	84
--------------------------	----

## Safety Labels

Label Locations .....	85
-----------------------	----

\* Not available on all models

The following pages explain your vehicle's safety features and how to use them properly. The safety precautions below are ones that we consider to be among the most important.

## Important Safety Precautions

### ■ Always wear your seat belt

A seat belt is your best protection in all types of collisions. Airbags are designed to supplement seat belts, not replace them. So even though your vehicle is equipped with airbags, make sure you and your passengers always wear your seat belts, and wear them properly.

### ■ Restrain all children

Children aged 12 and under should ride properly restrained in a back seat, not the front seat. Infants and small children should be restrained in a child restraint system. Larger children should use a booster seat and a lap/shoulder seat belt until they can use the belt properly without a booster seat.

### ■ Be aware of airbag hazards

While airbags can save lives, they can cause serious or fatal injuries to occupants who sit too close to them, or are not properly restrained. Infants, young children, and short adults are at the greatest risk. Be sure to follow all instructions and warnings in this manual.

### ■ Don't drink and drive

Alcohol and driving don't mix. Even one drink can reduce your ability to respond to changing conditions, and your reaction time gets worse with every additional drink. So don't drink and drive, and don't let your friends drink and drive, either.

### ▣ Important Safety Precautions

Some countries prohibit the use of mobile phones other than hands-free devices by the driver while driving.

**■ Pay appropriate attention to the task of driving safely**

Engaging in mobile phone conversation or other activities that keep you from paying close attention to the road, other vehicles, and pedestrians could lead to a crash. Remember, situations can change quickly, and only you can decide when it is safe to divert some attention away from driving.

**■ Control your speed**

Excessive speed is a major factor in crash injuries and deaths. Generally, the higher the speed, the greater the risk, but serious injuries can also occur at lower speeds. Never drive faster than is safe for current conditions, regardless of the maximum speed posted.

**■ Keep your vehicle in safe condition**

Having a tyre blowout or a mechanical failure can be extremely hazardous. To reduce the possibility of such problems, check your tyre pressures and condition frequently, and perform all regularly scheduled maintenance.

**■ Do not leave children unattended in the vehicle**

Children, pets and people needing assistance left unattended in the vehicle may be injured if they activate one or more of the vehicle controls. They may also cause the vehicle to move, resulting in a crash in which they and/or another person(s) can be injured or killed. Also, depending on the ambient temperature, the temperature of the interior may reach extreme levels, which can result in harm or death. Even if the cooling or climate control system is on, never leave them in the vehicle unattended as the cooling or climate control system can shut off at any time.

## Your Vehicle's Safety Features

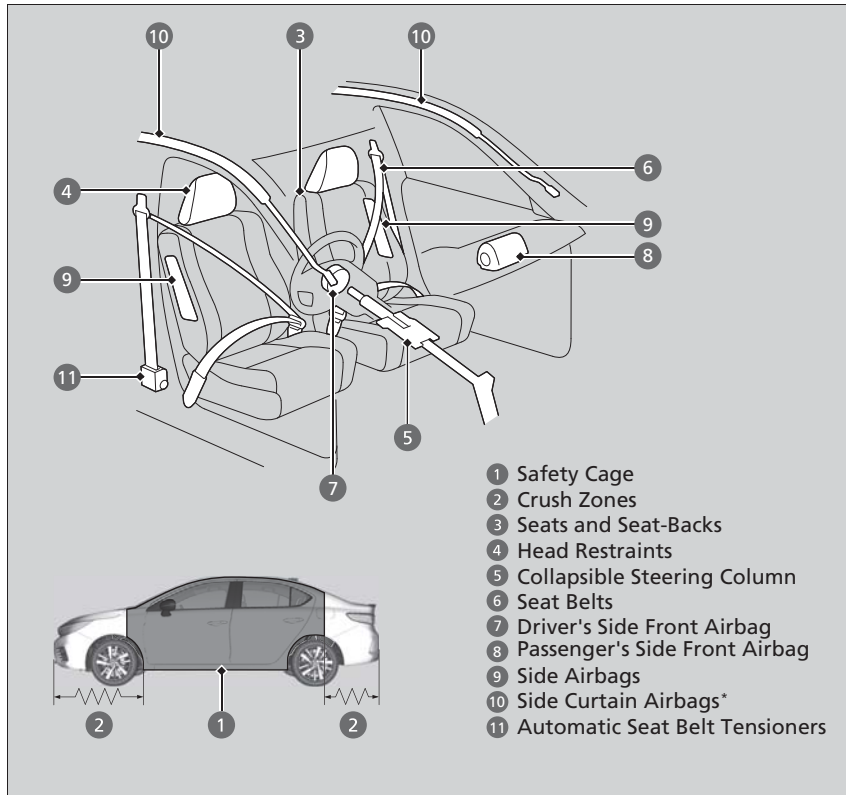

The following checklist will help you take an active role in protecting yourself and your passengers.

### ► Your Vehicle's Safety Features

Your vehicle is equipped with many features that work together to help to protect you and your passengers during a crash.

Some features do not require any action on your part. These include a strong steel framework that forms a safety cage around the passenger compartment, front and rear crush zones, a collapsible steering column, and tensioners that tighten the front seat belts in a sufficient crash.

However, you and your passengers cannot take full advantage of these features unless you remain seated in the correct position and always wear your seat belts. In fact, some safety features can contribute to injuries if they are not used properly.



## Safety Checklist

For the safety of you and your passengers, make a habit of checking these items each time before you drive.

- Adjust your seat to a position suitable for driving. Be sure the front seats are adjusted as far to the rear as possible while allowing the driver to control the vehicle. Sitting too close to a front airbag can result in serious or fatal injury in a crash.
  - **Seats** P. 175
- Adjust head restraints to the proper position. Head restraints are most effective when the centre of the head restraint aligns with the centre of your head. Taller persons should adjust their head restraint to the highest position.
  - **Adjusting the Front Head Restraints** P. 178
- Always wear your seat belt, and make sure you wear it properly. Confirm that any passengers are properly belted as well.
  - **Fastening a Seat Belt** P. 39
- Protect children by using seat belts or child restraint systems according to a child's age, height and weight.
  - **Child Safety** P. 54

### » Safety Checklist

#### Models with information display

If the door/boot open indicator is on, a door and/or boot is not completely closed. Close all doors and the boot tightly until the indicator goes off.

➤ **Door and Boot Open Indicator\*** P. 95



\* Not available on all models

*Continued*

» Safety Checklist

**Models with driver information interface**

If the door and/or boot open message appears on the driver information interface, a door and/or the boot is not completely closed. Close all doors and the boot tightly until the message disappears.

» **Driver Information Interface** \* P. 108



## About Your Seat Belts

Seat belts are the single most effective safety device because they keep you connected to the vehicle so that you can take advantage of many built-in safety features. They also help to keep you from being thrown against the inside of the vehicle, against any passengers, or out of the vehicle. When worn properly, seat belts also keep your body properly positioned in a crash so that you can take full advantage of the additional protection provided by the airbags.

In addition, seat belts help to protect you in almost every type of crash, including:

- frontal impacts
- side impacts
- rear impacts
- rollovers

### » About Your Seat Belts

#### **WARNING**

**Not wearing a seat belt properly increases the chance of serious injury or death in a crash, even though your vehicle has airbags.**

**Be sure you and your passengers always wear seat belts and wear them properly.**

**WARNING:** Seat belts are designed to bear upon the bony structure of the body, and should be worn low across the front of the pelvis or the pelvis, chest and shoulders, as applicable; wearing the lap section of the belt across the abdominal area must be avoided.

**WARNING:** Seat belts should be adjusted as firmly as possible, consistent with comfort, to provide the protection for which they have been designed. A slack belt will greatly reduce the protection afforded to the wearer.

**WARNING:** Belts should not be worn with straps twisted.

**WARNING:** Each belt assembly must only be used by one occupant; it is dangerous to put a belt around a child being carried on the occupant's lap.

### ■ Lap/shoulder seat belts

All five seating positions are equipped with lap/shoulder seat belts with emergency locking retractors. In normal driving the retractor lets you move freely while keeping some tension on the belt. During a collision or sudden stop the retractor locks to restrain your body.

The seat belt must be properly secured when using a front-facing child restraint system.

➤ **Installing a Child Restraint System with a Lap/Shoulder Seat Belt** P. 77

### ➤ About Your Seat Belts

Seat belts cannot completely protect you in every crash. But in most cases, seat belts can reduce your risk of serious injury.

Most countries require you to wear seat belts. Take time to familiarise with the legal requirements of the countries in which you will drive.

If you extend the seat belt too quickly, it will lock in place. If this happens, slightly retract the seat belt, then extend it slowly.

**■ Proper use of seat belts**

Follow these guidelines for proper use:

- All occupants should sit upright, well back in the seat, and remain in that position for the duration of the trip. Slouching and leaning reduce the effectiveness of the belt and can increase the chance of serious injury in a crash.
- Never place the shoulder part of a lap/shoulder seat belt under your arm or behind your back. This could cause very serious injuries in a crash.
- Two people should never use the same seat belt. If they do, they could be very seriously injured in a crash.
- Do not put any accessories on the seat belts. Devices intended to improve comfort or reposition the shoulder part of a seat belt can reduce the protective capability and increase the chance of serious injury in a crash.

## ■ Seat Belt Reminder

### ■ Front seats

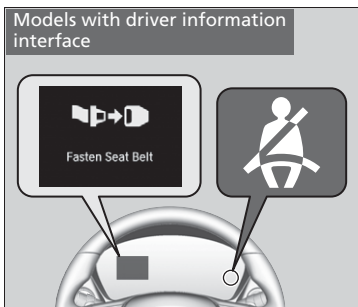
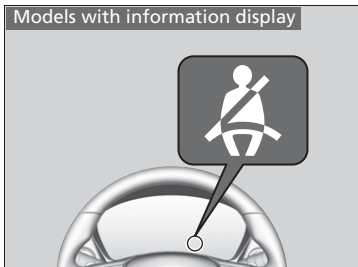

The seat belt system includes an indicator on the instrument panel to remind the driver or a front passenger or both to fasten their seat belts.

If you set the power mode to ON before the driver's seat belt is fastened, the indicator will blink. If the driver does not fasten the belt, the indicator will remain on.

The beeper will periodically sound and the indicator will blink while the vehicle is moving until the seat belt is fastened.

### ▶▶ Seat Belt Reminder

The indicator will also come on if a front passenger does not fasten their seat belt within six seconds after the power mode is set to ON.

When no one is sitting in the front passenger's seat, the indicator will not come on and the beeper will not sound.

If the indicator comes on or the beeper sounds with no one sitting in the front passenger's seat. Check if:

- There is nothing heavy placed on the front passenger seat.
- The driver's seat belt is fastened.

If the indicator does not light when the passenger is seated and is not fastened, something may be interfering with the occupant detection sensor. Check if:

- A cushion is placed on the seat.
- The front passenger is not sitting properly.

If none of these conditions exist, have your vehicle checked by a dealer.

## ■ Rear seats\*

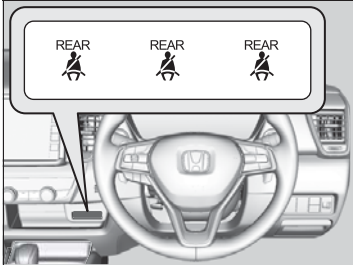

Your vehicle monitors rear seat belt use. Rear seat belt reminder indicator notifies you if any of the rear seat belts are not used.

The indicator comes on when:

- A rear door is opened and closed.
- Any of the rear passengers fastened or unfastened their seat belt.

The rear seat belt reminder indicator blinks and beeper sounds if any rear passenger's seat belt is unlatched while driving.

\* Not available on all models

## ■ Automatic Seat Belt Tensioners

The front seats are equipped with automatic seat belt tensioners to enhance safety.

The tensioners automatically tighten the front seat belts during a moderate-to-severe frontal collision, sometimes even if the collision is not severe enough to inflate the front airbags.

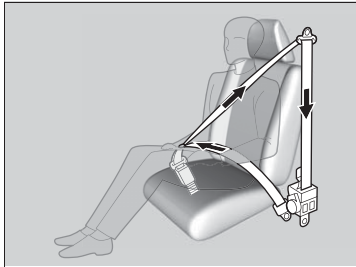

## ▶▶ Automatic Seat Belt Tensioners

The seat belt tensioners can only operate once. If a tensioner is activated, the SRS indicator will come on. Have a dealer replace the tensioner and thoroughly inspect the seat belt system as it may not offer protection in a subsequent crash.

### Models with side curtain airbags

During a moderate-to-severe side impact, the tensioner on that side of the vehicle also activates.



## Fastening a Seat Belt

After adjusting a front seat to the proper position, and while sitting upright and well back in the seat:

➤ Seats P. 175

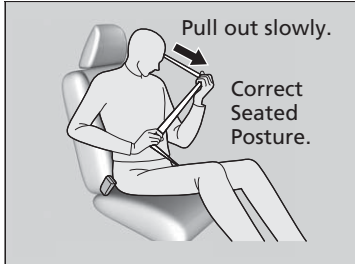

1. Pull the seat belt out slowly.

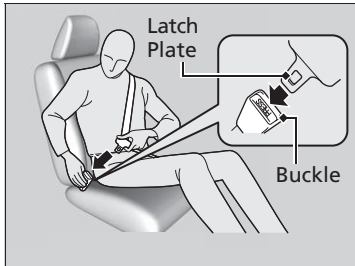

2. Insert the latch plate into the buckle, then tug on the belt to make sure the buckle is secure.

▶ Make sure that the belt is not twisted or caught on anything.

### Fastening a Seat Belt

No one should sit in a seat with an inoperative seat belt or one that does not appear to be working correctly. Using a seat belt that is not working properly may not protect the occupant in a crash. Have a dealer check the belt as soon as possible.

If the seat belt appears to be locked in a fully retracted position, firmly pull out on the shoulder belt once, then push it back in.

Then smoothly pull it out of the retractor and fasten. If you are unable to release the seat belt from a fully retracted position, do not allow anyone to sit in the seat, and take your vehicle to a dealer for repair.

➤ About Your Seat Belts P. 33

➤ Seat Belt Inspection P. 42



3. Position the lap part of the belt as low as possible across your hips, then pull up on the shoulder part of the belt so the lap part fits snugly. This lets your strong pelvic bones take the force of a crash and reduces the chance of internal injuries.
4. If necessary, pull up on the belt again to remove any slack, then check that the belt rests across the centre of your chest and over your shoulder. This spreads the forces of a crash over the strongest bones in your upper body.

▶ Fastening a Seat Belt

**⚠ WARNING**

Improperly positioning the seat belts can cause serious injury or death in a crash.

**Make sure all seat belts are properly positioned before driving.**

To release the belt, push the red **PRESS** button and then guide the belt by hand until it has retracted completely.

When exiting the vehicle, be sure the belt is properly stowed so that it will not get caught in the closing door.

Never insert any foreign objects into the buckle or retractor mechanism.

## Advice for Pregnant Women

If you are pregnant, the best way to protect yourself and your unborn child when driving or riding in a vehicle is to always wear a seat belt and keep the lap part of the belt as low as possible across the hips.

Wear the shoulder belt across the chest avoiding the abdomen.



Wear the lap part of the belt as low as possible across the hips.

## Advice for Pregnant Women

Each time you have a checkup, ask your doctor if it is okay for you to drive.

To reduce the risk of injuries to both you and your unborn child that can be caused by an inflating front airbag:

- When driving, sit upright and adjust the seat as far back as possible while allowing full control of the vehicle.
- When sitting in the front passenger's seat, adjust the seat as far back as possible.

## Seat Belt Inspection

Regularly check the condition of your seat belts as follows:

- Pull each belt out fully, and look for frays, cuts, burns, and wear.
- Check that the latch plates and buckles work smoothly and the belts retract easily.
  - ▶ If a belt does not retract easily, cleaning the belt may correct the problem. Only use a mild soap and warm water. Do not use bleach or cleaning solvents. Make sure the belt is completely dry before allowing it to retract.

Any belt that is not in good condition or working properly will not provide proper protection and should be replaced as soon as possible.

A belt that has been worn during a crash may not provide the same level of protection in a subsequent crash. Have your seat belts inspected by a dealer after any collision.

### ▶▶ Seat Belt Inspection

#### **WARNING**

**Not checking or maintaining seat belts can result in serious injury or death if the seat belts do not work properly when needed.**

**Check your seat belts regularly and have any problem corrected as soon as possible.**

**WARNING:** No modifications or additions should be made by the user which will either prevent the seat belt adjusting devices from operating to remove slack, or prevent the seat belt assembly from being adjusted to remove slack.

**WARNING:** It is essential to replace the entire assembly after it has been worn in a severe impact even if damage to the assembly is not obvious.

**WARNING:** Care should be taken to avoid contamination of the webbing with polishes, oils and chemicals, and particularly battery acid. Cleaning may safely be carried out using mild soap and water. The belt should be replaced if webbing becomes frayed, contaminated or damaged.

## Anchorage Points

Front Seat



When replacing the seat belts, use the anchorage points shown in the images. The front seat has a lap/shoulder belt.

Rear Seat

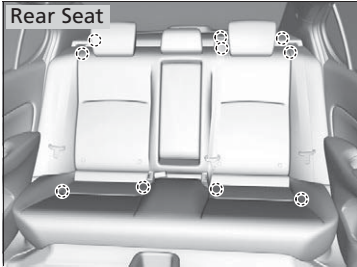

The rear seat has three lap/shoulder belts.

## Airbag System Components

The front, front side, and side curtain\* airbags are deployed according to the direction and severity of impact. The airbag system includes:

- Two SRS (Supplemental Restraint System) front airbags. The driver's airbag is stored in the centre of the steering wheel; the front passenger's airbag is stored in the dashboard. Both are marked **SRS AIRBAG**.
- Two side airbags, one for the driver and one for a front passenger. The airbags are stored in the outer edges of the seat-backs. Both are marked **SIDE AIRBAG**.

### Models with side curtain airbags

- Two side curtain airbags, one for each side of the vehicle. The airbags are stored in the ceiling, above the side windows. The front and rear pillars are marked **SIDE CURTAIN AIRBAG**.

- An electronic control unit that, when the power mode is in ON, continually monitors information about the various impact sensors, seat and buckle sensors, airbag activators, seat belt tensioners, and other vehicle information. During a crash event the unit can record such information.
- Automatic front seat belt tensioners.
- Impact sensors that can detect a moderate-to-severe front or side impact.
- An indicator on the instrument panel that alerts you to a possible problem with your airbag system or seat belt tensioners.

## Important Facts About Your Airbags

Airbags can pose serious hazards. To do their job, airbags must inflate with tremendous force. So, while airbags help to save lives, they can cause burns, bruises, and other minor injuries, sometimes even fatal ones if occupants are not wearing their seat belts properly and sitting correctly.

**What you should do:** Always wear your seat belt properly, and sit upright and as far back from the steering wheel as possible while allowing full control of the vehicle. A front passenger should move their seat as far back from the dashboard as possible.

Remember, however, that no safety system can prevent all injuries or deaths that can occur in a severe crash, even when seat belts are properly worn and the airbags deploy.

**Do not place hard or sharp objects between yourself and a front airbag.**

Carrying hard or sharp objects on your lap, or driving with a pipe or other sharp object in your mouth, can result in injuries if your front airbag inflates.

**Do not attach or place objects on the front airbag covers.** Objects on the covers marked **SRS AIRBAG** could interfere with the proper operation of the airbags or be propelled inside the vehicle and hurt someone if the airbags inflate.

## Important Facts About Your Airbags

Do not attempt to deactivate your airbags. Together, airbags and seat belts provide the best protection.

When driving, keep hands and arms out of the deployment path of the front airbag by holding each side of the steering wheel. Do not cross an arm over the airbag cover.

## Types of Airbags

Your vehicle is equipped with three types of airbags:

- **Front airbags:** Airbags in front of the driver's and front passenger's seats.
- **Side airbags:** Airbags in the driver's and front passenger's seat-backs.
- **Side curtain airbags\*:** Airbags above the side windows.

Each is discussed in the following pages.

### Front Airbags (SRS)

The front SRS airbags inflate in a moderate-to-severe frontal collision to help to protect the head and chest of the driver and/or front passenger.

**SRS** (Supplemental Restraint System) indicates that the airbags are designed to supplement seat belts, not replace them. Seat belts are the occupant's primary restraint system.

#### Housing Locations

The front airbags are housed in the centre of the steering wheel for the driver, and in the dashboard for the front passenger. Both airbags are marked **SRS AIRBAG**.

#### Types of Airbags

The airbags can inflate whenever the power mode is set to ON.

After an airbag inflates in a crash, you may see a small amount of smoke. This is from the combustion process of the inflator material and is not harmful. People with respiratory problems may experience some temporary discomfort. If this occurs, get out of the vehicle as soon as it is safe to do so.



## ■ Operation

Front airbags are designed to inflate during moderate-to-severe frontal collisions. When the vehicle decelerates suddenly, the sensors send information to the control unit which signals one or both front airbags to inflate.

A frontal collision can be either head-on or angled between two vehicles, or when a vehicle crashes into a stationary object, such as a concrete wall.

## ■ How the Front Airbags Work

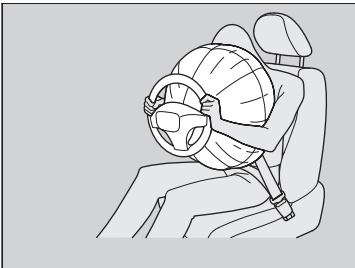

While your seat belt restrains your torso, the front airbag provides supplemental protection for your head and chest.

The front airbags deflate immediately so that they won't interfere with the driver's visibility or the ability to steer or operate other controls.

The total time for inflation and deflation is so fast that most occupants are not aware that the airbags deployed until they see them lying in front of them.

### ■ When front airbags should not deploy

**Minor frontal crashes:** Front airbags were designed to supplement seat belts and help to save lives, not to prevent minor scrapes, or even broken bones that might occur during a less than moderate-to-severe frontal crash.

**Side impacts:** Front airbags can provide protection when a sudden deceleration causes a driver or front passenger to move towards the front of the vehicle. Side airbags and side curtain airbags\* have been specifically designed to help to reduce the severity of injuries that can occur during a moderate-to-severe side impact which can cause the driver or passenger to move towards the side of the vehicle.

**Rear impacts:** Head restraints and seat belts are your best protection during a rear impact. Front airbags cannot provide any significant protection and are not designed to deploy in such collisions.

**Rollovers:** Seat belts and side curtain airbags\* offer the best protection in a rollover. Because front airbags could provide little if any protection, they are not designed to deploy during a rollover.

### ■ When front airbags deploy with little or no visible damage

Because the airbag system senses sudden deceleration, a strong impact to the vehicle framework or suspension might cause one or more of the airbags to deploy. Examples include running into a curb, the edge of a hole, or other low fixed object that causes a sudden deceleration in the vehicle chassis. Since the impact is underneath the vehicle, damage may not be readily apparent.

### ■ When front airbags may not deploy, even though exterior damage appears severe

Since crushable body parts absorb crash energy during an impact, the amount of visible damage does not always indicate proper airbag operation. In fact, some collisions can result in severe damage but no airbag deployment because the airbags would not have been needed or would not have provided protection even if they had deployed.

## Side Airbags

The side airbags help to protect the torso and pelvis of the driver or a front passenger during a moderate-to-severe side impact.

### Housing Locations

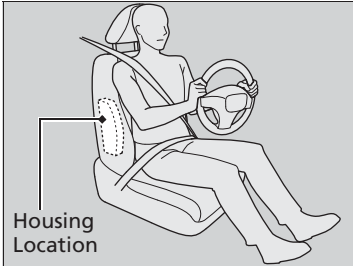

The side airbags are housed in the outside edge of the driver's and passenger's seat-backs.

Both are marked **SIDE AIRBAG**.

### Side Airbags

Do not let the front passenger lean sideways with their head in the deployment path of the side airbag. An inflating side airbag can strike with strong force and seriously injure the passenger.

Do not attach accessories on or near the side airbags. They can interfere with the proper operation of the airbags, or hurt someone if an airbag inflates.

## ■ Operation

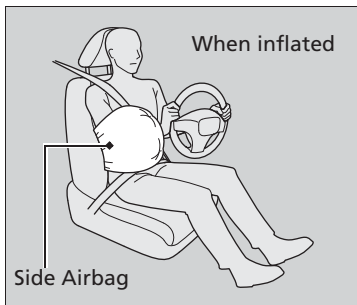

When the sensors detect a moderate-to-severe side impact, the control unit signals the side airbag on the impact side to immediately inflate.

### ■ When a side airbag deploys with little or no visible damage

Because the airbag system senses sudden acceleration, a strong impact to the side of the vehicle's framework can cause a side airbag to deploy. In such cases, there may be little or no damage, but the side impact sensors detected a severe enough impact to deploy the airbag.

### ■ When a side airbag may not deploy, even though visible damage appears severe

It is possible for a side airbag not to deploy during an impact that results in apparently severe damage. This can occur when the point of impact was towards the far front or rear of the vehicle, or when the vehicle's crushable body parts absorbed most of the crash energy. In either case, the side airbag would not have been needed nor provided protection even if it had deployed.

## ▶ Side Airbags

Do not cover or replace the front seat-back covers without consulting a dealer. Improperly replacing or covering front seat-back covers can prevent your side airbags from properly deploying during a side impact.

# Side Curtain Airbags\*

The side curtain airbags help to protect the heads of the driver and passengers in outer seating positions during a moderate-to-severe side impact.

## ■ Housing Locations

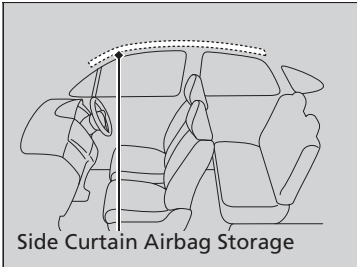

Side Curtain Airbag Storage

The side curtain airbags are located in the ceiling above the side windows on both sides of the vehicle.

## ■ Operation

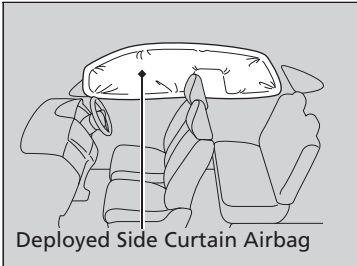

Deployed Side Curtain Airbag

The side curtain airbag is designed to deploy in a moderate-to-severe side impact.

### ■ When side curtain airbags deploy in a frontal collision

One or both side curtain airbags may also inflate in a moderate-to-severe angled frontal collision.

### ▶▶ Side Curtain Airbags\*

The side curtain airbags are most effective when an occupant is wearing their seat belt properly and sitting upright, well back in their seat.

Do not attach any objects to the side windows or roof pillars as they can interfere with the proper operation of the side curtain airbags.

#### Models with coat hook

Do not put a coat hanger or hard objects on a coat hook. This could result in injuries if your side curtain airbag inflates.

\* Not available on all models

## Airbag System Indicators

### Models with information display

If a problem occurs in the airbag system, the SRS indicator will come on.

### Models with driver information interface

If a problem occurs in the airbag system, the SRS indicator will come on and a message appears on the driver information interface.

## ■ Supplemental Restraint System (SRS) Indicator

### Models with information display



### ■ When the power mode is set to ON

The indicator comes on for a few seconds, then goes off. This tells you the system is working properly.

If the indicator comes on at any other time, or does not come on at all, have the system checked by a dealer as soon as possible. If you don't, your airbags and seat belt tensioners may not work properly when they are needed.

### Models with driver information interface



### ▶▶ Supplemental Restraint System (SRS) Indicator

## ⚠ WARNING

Ignoring the SRS indicator can result in serious injury or death if the airbag systems or tensioners do not work properly.

Have your vehicle checked by a dealer as soon as possible if the SRS indicator alerts you to a possible problem.

## Airbag Care

---

You do not need to, and should not, perform any maintenance on or replace any airbag system components yourself. However, you should have your vehicle inspected by a dealer in the following situations:

### ■ When the airbags have deployed

If an airbag has inflated, the control unit and other related parts must be replaced. Similarly, once an automatic seat belt tensioner has been activated, it must be replaced.

### ■ When the vehicle has been in a moderate-to-severe collision

Even if the airbags did not inflate, have your dealer inspect the following: front seat belt tensioners, and each seat belt that was worn during the crash.

#### ⓘ Airbag Care

The removal of airbag components from the vehicle is prohibited.

In case of malfunction, or shutdown, or after the airbag inflation/seat belt tensioner operation, ask a qualified personnel for handling.

We recommend against the use of salvaged airbag system components, including the airbag, tensioners, sensors, and control unit.

## Protecting Child Passengers

Each year, many children are injured or killed in vehicle crashes because they are either unrestrained or not properly restrained. In fact, vehicle crashes are the number one cause of death of children aged 12 and under.

To reduce the number of child deaths and injuries, infants and children should be properly restrained when they ride in a vehicle.

**Children should sit properly restrained in a rear seat.** This is because:

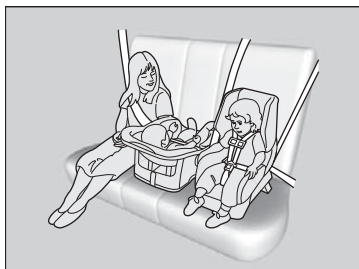

- An inflating front or side airbag can injure or kill a child sitting in the front seat.
- A child in the front seat is more likely to interfere with the driver's ability to safely control the vehicle.
- Statistics show that children of all sizes and ages are safer when they are properly restrained in a rear seat.

### Protecting Child Passengers

Front Passenger's Sun Visor

#### **WARNING**



**NEVER** use a rearward facing child restraint on a seat protected by an **ACTIVE AIRBAG** in front of it, **DEATH** or **SERIOUS INJURY** to the **CHILD** can occur.



- Any child who is too small to wear a seat belt must be properly restrained in an approved child restraint system that is properly secured to the vehicle using the seat belt or the child restraint anchorage system.
- Never hold a child on your lap because it is impossible to protect them in the event of a collision.
- Never put a seat belt over yourself and a child. During a crash, the belt would likely press deep into the child and cause serious or fatal injuries.
- Never let two children use the same seat belt. Both children could be very seriously injured in a crash.

#### ▶▶ Protecting Child Passengers

### **WARNING**

**Children who are unrestrained or improperly restrained can be seriously injured or killed in a crash.**

**Any child too small for a seat belt should be properly restrained in an approved child restraint system. A larger child should be properly restrained with a seat belt, using a booster seat if necessary.**

In many countries, the law requires all children aged 12 and under, and whose height are shorter than 150 cm be properly restrained in a rear seat.

In many countries, it is required to use an officially approved and suitable child restraint system for transporting a child on any passenger seat. Check your local legal requirement.

We recommend that child restraint systems meet UN Regulation No. 44 or No. 129\*, or the regulations of the subject countries.

\* Not available on all models

- Do not allow children to operate the doors, windows or seat adjustments.
- Do not leave children in the vehicle unattended, especially in hot weather when the inside of the vehicle can get hot enough to kill them. They could also activate vehicle controls causing it to move unexpectedly.

▶▶ Protecting Child Passengers

Front Passenger's Doorjamb\*

**⚠ WARNING**



**Extreme Hazard!**

**DO NOT use a rear-facing child restraint on a seat protected by an airbag in front of it!**

**WARNING:** Use the power window lock button to prevent children from opening the windows. Using this feature will prevent children from playing with the windows, which could expose them to hazards or distract the driver.

**🔒 Opening/Closing the Power Windows**

P. 151

**WARNING:** Always take the ignition key with you whenever you leave the vehicle alone or with other occupants.

▶▶ Protecting Child Passengers

To remind you of the passenger's front airbag hazard and child safety, your vehicle has the warning label on the passenger's side sun visor.

Please read and follow the instructions on this label.

▶ **Safety Labels** P. 85

## Safety of Infants and Small Children

### ■ Protecting Infants

An infant must be properly restrained in a rear-facing, reclining child restraint system until the infant reaches the child restraint system manufacturer's weight or height limit for the seat, and the infant is at least one year old.

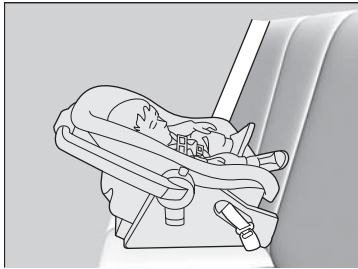

#### ■ Positioning a rear-facing child restraint system

Child restraint system must be placed and secured in a rear seating position.

- ▶ We recommend that you install the child restraint system directly behind the front passenger's seat, move the seat as far forward as needed, and leave it unoccupied.
- ▶ Make sure that there is no contact between the child restraint system and the seat in front of it.  
If there is, you may wish to get a smaller rear-facing child restraint system.

### ▶▶ Protecting Infants

#### **⚠ WARNING**

Placing a rear-facing child restraint system in the front seat can result in serious injury or death if the passenger's front airbag inflates.

Always place a rear-facing child restraint system in the back seat, not the front.

When properly installed, a rear-facing child restraint system may prevent the driver or a front passenger from moving their seat all the way back, or from locking their seat-back in the desired position.

▶▶ Protecting Infants

As required by UN Regulation No. 94:

<b>⚠ WARNING</b>		
<b>⚠ AIRBAG</b>		
<b>NEVER use a rearward facing child restraint on a seat protected by an ACTIVE AIRBAG in front of it, DEATH or SERIOUS INJURY to the CHILD can occur.</b>		

If the passenger's front airbag inflates, it can hit the rear-facing child restraint system with great force, which can dislodge or strike the system, and seriously injure the child.

Rear-facing child restraint systems should never be installed in a front-facing position.

Always refer to the child restraint system manufacturer's instructions before installation.

## ■ Protecting Smaller Children

If a child is at least one year old and has exceeded the weight and height limitations of a rear-facing child restraint system, the child should be properly restrained in a firmly secured front-facing child restraint system until they exceed the weight and height limitations for the front-facing child restraint system.

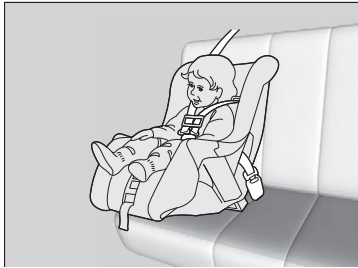

### ■ Front-facing child restraint system placement

We strongly recommend placing a front-facing child restraint system in a rear seating position.

Placing a front-facing child restraint system in the front seat can be hazardous. A rear seat is the safest place for a child.

## ▶▶ Protecting Smaller Children

### ⚠ WARNING

Placing a front-facing child restraint system in the front seat can result in serious injury or death if the front airbag inflates.

If you must place a front-facing child restraint system in front, move the vehicle seat as far back as possible, and properly restrain the child.

Educate yourself about the laws and regulations regarding child restraint system use where you are driving, and follow the child restraint system manufacturer's instructions.

Many experts recommend use of a rear-facing child restraint system for a child up to two years old if the child's height and weight are appropriate for a rear-facing child restraint system.

## ■ Selecting a Child Restraint System

Some child restraint systems are lower anchorage compatible. Some have a rigid-type connector, while others have a flexible-type connector. Both are equally easy to use. Some existing and previously owned child restraint systems can only be installed using the seat belt. Whichever type you choose, follow the child restraint system manufacturer's use and care instructions including recommended expiration dates as well as the instructions in this manual. Proper installation is key to maximising your child's safety.

The flexible type may not be available in your country.

In seating positions and vehicles not equipped with lower anchorages, install a child restraint system using the seat belt and a top tether for added security. This is because all child restraint systems must be secured with the seat belt when the lower anchorage system is not in use. In addition, the child restraint system manufacturer may advise that a seat belt be used to attach an ISOFIX restraint system once a child reaches a specified weight. Please read the child restraint system owner's manual for proper installation instructions.

### ■ Important consideration when selecting a child restraint system

Make sure the child restraint system meets the following three requirements:

- The child restraint system is the correct type and size for the child.
- The child restraint system is the correct type for the seating position.
- The child restraint system is compliant with safety standards. We recommend a child restraint system compliant with UN Regulation No. 44 or No. 129\*, or the regulations of the subject countries. Look for the approval mark on the system and the manufacturer's statement of compliance on the box.

### ▶▶ Selecting a Child Restraint System

Installation of a lower anchorage-compatible child restraint system is simple.

Lower anchorage-compatible child restraint systems have been developed to simplify the installation process and reduce the likelihood of injuries caused by incorrect installation.

We recommend a rear-facing or a front-facing Honda genuine ISOFIX child restraint system for infants or small children, respectively. Ask your dealer.

\* Not available on all models

### ■ Child Restraint Systems Standards

If a child restraint system (whether an i-Size/ISOFIX type or one that is fitted with a seat belt) meets the relevant UN Regulation, it will be affixed with an approval label as shown in the adjacent table. Before purchasing or using any child restraint system, make sure to check the approval label and ensure that it is compatible with your vehicle and the child, and that it complies with the relevant UN Regulation.

#### ▶▶ Selecting a Child Restraint System

Example of UN Regulation No. 44 approval label

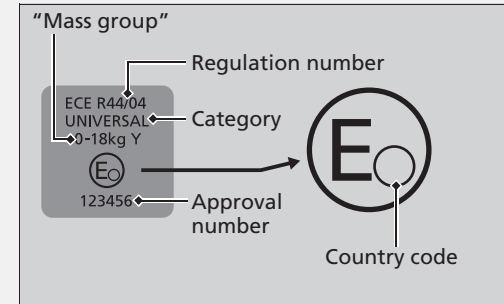

Example of UN Regulation No. 129 approval label\*

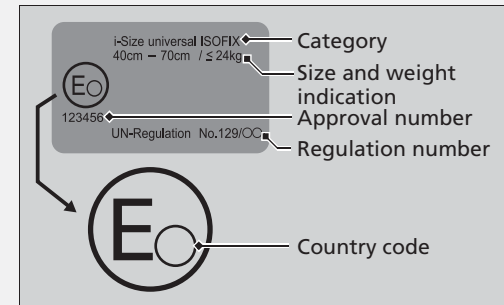



Indian Models

■ ISOFIX Child Restraint Systems

MASS Group	Size Class	Fixture	Vehicle ISOFIX positions				Recommended Child Restraint Systems* <sup>1</sup>
			Front passenger	Rear seat			
				L-Side	R-Side	Centre	
Carrycot	F	ISO/L1	X	X	X	X	
	G	ISO/L2	X	X	X	X	
Group 0 up to 10 kg	E	ISO/R1	X	IL	IL	X	Honda genuine ISOFIX (Rear facing)
Group 0+ up to 13 kg	E	ISO/R1	X	IL	IL	X	Honda genuine ISOFIX (Rear facing)
	D	ISO/R2	X	IL	IL	X	Honda genuine ISOFIX (Rear facing)
	C	ISO/R3	X	IL	IL	X	Honda genuine ISOFIX (Rear facing)
Group I 9 to 18 kg	D	ISO/R2	X	IL	IL	X	
	C	ISO/R3	X	IL	IL	X	
	B	ISO/F2	X	IUF, IL	IUF, IL	X	IL: Honda genuine ISOFIX (Front facing)
	B1	ISO/F2X	X	IUF, IL	IUF, IL	X	IL: Honda genuine ISOFIX (Front facing)
	A	ISO/F3	X	IUF, IL	IUF, IL	X	IL: Honda genuine ISOFIX (Front facing)
Group II 15 to 25 kg			X	X	X	X	
Group III 22 to 36 kg			X	X	X	X	

☒ ISOFIX Child Restraint Systems

When purchasing a child restraint systems, make sure to check the ISOFIX size class or the fixture to ensure that the seat is compatible with your vehicle.

ISOFIX Size Class	Fixture (CRF)	Description
G	ISO/L2	Right lateral-facing (carrycot) infant seat
F	ISO/L1	Left lateral-facing (carrycot) infant seat
E	ISO/R1	Rearward-facing infant seat
D	ISO/R2	Reduced-size rearward-facing child restraint systems
C	ISO/R3	Full-size rearward-facing child restraint systems
B1	ISO/F2X	Reduced-height forward-facing child restraint systems
B	ISO/F2	Reduced-height forward-facing child restraint systems
A	ISO/F3	Full-height, forward-facing child restraint systems

- 
- IUF: Suitable for forward-facing ISOFIX child restraints system of universal category approved for use in this mass group.
- IL: Suitable for particular ISOFIX child restraint systems (CRS), including those listed in the corresponding box in the right column of the table. These ISOFIX CRS are those of the 'specific vehicle', 'restricted' or 'semi-universal' categories.
- X: Seat position not suitable for children in this mass group.
- \* 1: The named Child Restraint Systems (CRS) reflect Honda's recommendations at the date of publication. You should speak to an authorised dealer for up-to-date details relating to our recommended CRSs. Other CRS may also be suitable - please consult CRS manufacturers for recommended vehicle lists.
-

## ■ Child Restraint Systems to be Installed with a Lap/Shoulder Seat Belt

Not all of the various types of child restraint systems are suitable for use in your vehicle. Before you purchase or use a child restraint system, refer to the following table to ensure that the child restraint system is appropriate for the vehicle, the seating position, and the child's weight (mass group) and size.

### ☒ Child Restraint Systems to be Installed with a Lap/Shoulder Seat Belt

Mass group is specified for some child restraint systems. Make sure to check the mass group as indicated in the manufacturer's instructions as well as on the package and labels of the child restraint system.

The particular child restraint systems listed in the table are genuine Honda products. They are available from your dealer.

For correct installation, refer to the instructions manual that came with the child restraint system.

Indian Models

■ Child Restraint Systems installed with Seat Belt

MASS Group	Seating position				Recommended Child Restraint Systems*1
	Front passenger seat	Rear seat			
		L-side	R-side	Centre	
Group 0 up to 10 kg	X	U	U	X	
Group 0+ up to 13 kg	X	U	U	X	
Group I 9 kg to 18 kg	UF*2	U	U	UF	
Group II 15 kg to 25 kg	UF*2	U	U	UF	
Group III 22 kg to 36 kg	UF*2	U	U	UF	

- U: Suitable for 'universal' category restraints approved for use in this mass group.
- UF: Suitable for forward facing 'universal' category restraints approved for use in this mass group.
- L: Suitable for particular child restraint systems given in this list. These restraints may be of the "specific vehicle," "restricted," or "semi-universal" category.
- X: Seat position not suitable for children in this mass group.
- \*1: The named Child Restraint Systems (CRS) reflect Honda's recommendations at the date of publication. You should speak to an authorised dealer for up to date details relating to our recommended CRSs. Other CRS may also be suitable - please consult CRS manufacturers for recommended vehicle lists.
- \*2: Move the front seat to its slide rail rearmost position and adjust the front seat-back angle to its most upright position. And if the CRS and headrest interfere, remove the headrest. The removed headrest should be stored in the luggage compartment so that it does not fly during sudden braking or collision.  
Also, remove the CRS and if an adult is seated, attach the headrest restraint to the original seat and make sure it is locked.

#### Indian Models

A size class is specified for some child restraint systems. Make sure to check the size class as indicated on the manufacturer's instructions, package, and labels of the child restraint.

For a correct installation, please refer to the Child Restraint Instruction Manual.

Malaysian models

■ Locations for Child Restraint System Installation



	Suitable for universal restraint systems installed with vehicle safety belts.
	Suitable for forward facing universal restraint systems installed with vehicle safety belts.
	Suitable for i-Size and ISOFIX child restraints systems.
	Suitable for forward facing restraint systems only.
	Never use a rearward facing child restraint system.
	Seat position equipped with Top Tether anchorages.

\*1: Adjust the seat slide to the rearmost position and adjust the seat back to the most front lock position.

\*2: Forward facing only

\*4: The head restraint must be removed when attaching a forward facing booster seat approved by UN R129. Store the removed head restraint in the luggage compartment so that it does not fly during sudden braking or collision. Also, when the booster seat is removed, attach the head restraint to the original seat again and make sure it is locked.

\*5: If you can not fix the child restraint system stably, adjust the seat-back angle to be parallel with the back side of the child restraint system, still keeping it forward of the seat belt shoulder anchor.

Child restraint systems with support legs can be installed on non i-Size seating positions. However, the centre seat is excluded.

Seat position number	Size groups Weight Stature		Seating position			
			①	②	③	④
			Front passenger* <sup>1, *5</sup>	2nd row		
Left	Centre	Right				
Seating position suitable for universal belted (yes/no)	Group 0	Up to 10 kg	No	Yes	No	Yes
	Group 0+	Up to 13 kg				
	Group I	9-18 kg	Yes* <sup>2</sup>	Yes	Yes* <sup>2</sup>	Yes
	Group II	15-25 kg				
	Group III	22-36 kg				
i-Size seating position (yes/no)	≤ 150 cm		No	Yes	No	Yes
Seating position suitable for recommended genuine CRS* <sup>3</sup>	Refer to genuine CRS list		No	Yes	No	Yes
Seating position suitable for lateral fixture (L1/L2)	—		No	No	No	No
Largest suitable rearward facing fixture (R1/R2X/R2/R3)	Group 0	Up to 10 kg	No	R3	No	R3
	Group 0+	Up to 13 kg				
	Group I	9-18 kg				
Largest suitable forward facing fixture (F2X/F2/F3)	Group I	9-18 kg	No	F3	No	F3
Largest suitable booster fixture (B2/B3)	≤ 150 cm		B3* <sup>4</sup>	B3	B3	B3

- \*1: Adjust the seat slide to the rearmost position and adjust the seat back to the most front lock position.
- \*2: Forward facing only
- \*3: The named Child Restraint Systems (CRS) reflect Honda's recommendations at the date of publication. You should speak to an authorised dealer for up to date details relating to our recommended CRSs. Other CRS may also be suitable - please consult CRS manufacturers for recommended vehicle lists.
- \*4: The head restraint must be removed when attaching a forward facing booster seat approved by UN R129. Store the removed head restraint in the luggage compartment so that it does not fly during sudden braking or collision. Also, when the booster seat is removed, attach the head restraint to the original seat again and make sure it is locked.
- \*5: If you can not fix the child restraint system stably, adjust the seat-back angle to be parallel with the back side of the child restraint system, still keeping it forward of the seat belt shoulder anchor.

Child restraint systems with support legs can be installed on non i-Size seating positions. However, the centre seat is excluded.

► Locations for Child Restraint System Installation

When purchasing a child restraint systems, make sure to check the ISOFIX size class or the fixture to ensure that the seat is compatible with your vehicle.

Fixture (CRF)	Description
ISO/L1	Left lateral-facing (carrycot) infant seat
ISO/L2	Right lateral-facing (carrycot) infant seat
ISO/R1	Rearward-facing infant seat
ISO/R2X	Reduced-size rearward-facing child restraint systems
ISO/R2	Reduced-size rearward-facing child restraint systems
ISO/R3	Full-size rearward-facing child restraint systems
ISO/F2X	Reduced-height forward-facing child restraint systems
ISO/F2	Reduced-height forward-facing child restraint systems
ISO/F3	Full-height, forward-facing child restraint systems
ISO/B2	Reduced width forward-facing booster seat
ISO/B3	Full width forward-facing booster seat



**■ Malaysian Genuine CRS List**

**R44**

Mass Group	Child Restraint System	Category
Group 0 up to 10 kg	—	—
Group 0+ up to 13 kg	—	—
Group I 9 to 18 kg	—	—
Group II, III 15 to 36 kg	—	—

**R129**

Range of application	Child Restraint System	Category
40 to 83 cm up to 13 kg (Birth - 15 months)	Honda Baby & Kids i-size	i-Size Universal ISOFIX (Rear facing)
76 to 105 cm 8 to 22 kg (15 months - 4 years)	Honda Baby & Kids i-size	i-Size Universal ISOFIX

■ Indian Genuine CRS List

R44

Mass Group	Child Restraint System	Category
Group 0 up to 10 kg	Honda genuine ISOFIX	Semi-universal ISOFIX (Rear facing)
Group 0+ up to 13 kg	Honda genuine ISOFIX	Semi-universal ISOFIX (Rear facing)
Group I 9 to 18 kg	Honda genuine ISOFIX	Semi-universal ISOFIX (Front facing)
Group II, III 15 to 36 kg	—	—

## ■ Installing a Lower Anchorage-Compatible Child Restraint System

A lower anchorage-compatible child restraint system can be installed in either of the two outer rear seats. A child restraint system is attached to the lower anchorages with either the rigid or flexible type of connectors.

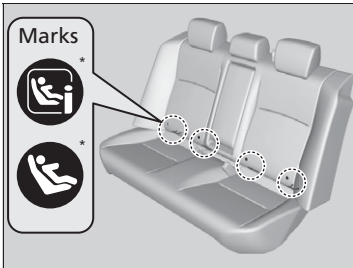

1. Locate the lower anchorages under the marks.

\* Not available on all models

## ▶▶ Installing a Lower Anchorage-Compatible Child Restraint System

### ⚠ WARNING

Never attach two child restraint systems to the same anchor. In a collision, one anchor may not be strong enough to hold two child restraint system attachments and may break, causing serious injury or death.

Some child restraint systems come with optional guide-cups, which avoid possible damage to the seat surface. Follow the manufacturer's instructions when using the guide-cups, and attach them to the lower anchorages as shown in the image.

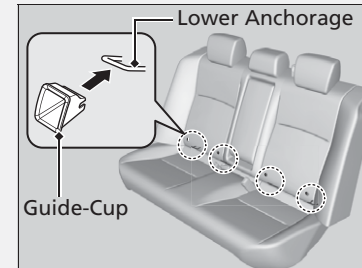

Continued

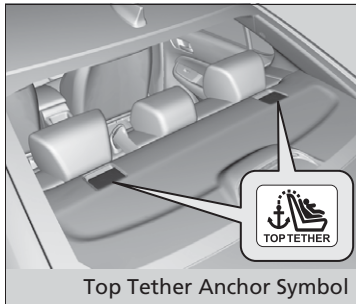
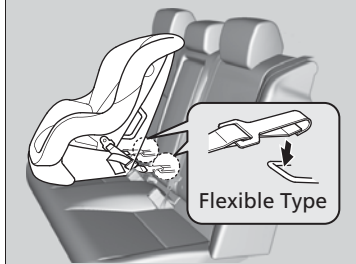
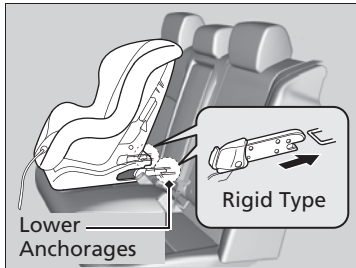

2. Place the child restraint system on the vehicle seat, then attach the child restraint system to the lower anchorages according to the instructions that came with the child restraint system.

▶ When installing the child restraint system, make sure that the lower anchorages are not obstructed by the seat belt or any other object.

#### ▶▶ Installing a Lower Anchorage-Compatible Child Restraint System

For your child's safety, when using a child restraint system installed using the lower anchorage system, make sure that the child restraint system is properly secured to the vehicle.

A child restraint system that is not properly secured will not adequately protect a child in a crash and may cause injury to the child or other vehicle occupants.

The flexible type may not be available in your country.

**WARNING:** Never use a hook that does not come with a Top Tether anchor symbol when securing an installed child restraint system.

#### Child restraint system with tether strap

3. Open the tether anchorage cover behind the head restraint or pillow.

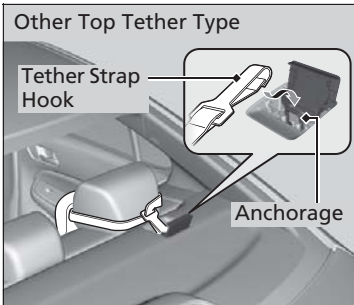
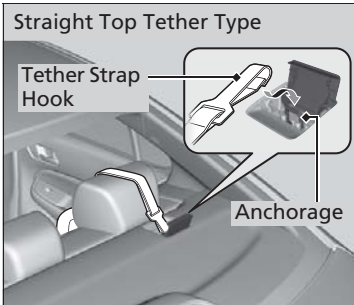

4. Route the tether strap as shown, and secure the tether strap hook to the anchorage. Make sure the strap is not twisted.
5. Tighten the tether strap as instructed by the child restraint system manufacturer.
6. Make sure the child restraint system is firmly secured by rocking it forward and back, and side to side; little movement should be felt.
7. Make sure any unused seat belt that a child can reach is buckled, the lockable retractor is activated, and the belt is fully retracted and locked.

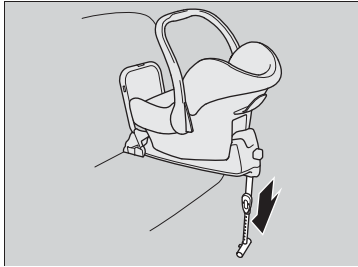

**Child restraint system with support leg\***

- 3.** Extend the support leg until it touches the floor as instructed by the child restraint system manufacturer.
  - ▶ Confirm that the section of the floor on which the support leg rests is level. If the section is not level, the support leg will not provide adequate support.
  - ▶ Make sure that there is no contact between the child restraint system and the seat in front of it.

## ■ Installing a Child Restraint System with a Lap/Shoulder Seat Belt

A child seat can be installed with a lap/shoulder belt in any rear seat or, if absolutely necessary, the front passenger seat.

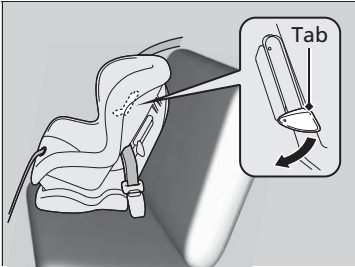
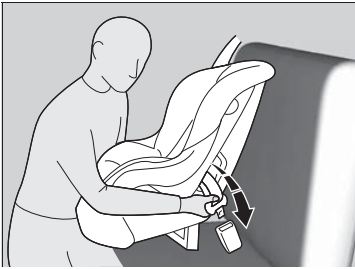

1. Place the child restraint system on the vehicle seat.
2. Route the seat belt through the child restraint system according to the child restraint system manufacturer's instructions, and insert the latch plate into the buckle.
  - ▶ Insert the latch plate fully until it clicks.
3. Push down the tab. Route the shoulder part of the belt into the slit at the side of the restraint.
4. Grab the shoulder part of the belt near the buckle, and pull up to remove any slack from the lap part of the belt.
  - ▶ When doing this, place your weight on the child restraint system and push it into the vehicle seat.
5. Position the belt properly and push up the tab. Make sure the belt is not twisted.
  - ▶ When pushing up the tab, pull up the upper shoulder part of the belt to remove any slack from the belt.

## ⊠ Installing a Child Restraint System with a Lap/Shoulder Seat Belt

A child restraint system that is not properly secured will not adequately protect a child in a crash and may cause injury to the child or other vehicle occupants.

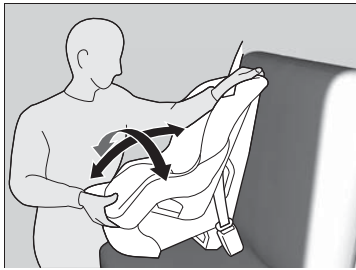

6. Make sure the child restraint system is firmly secured by rocking it forward and back, and side to side; little movement should be felt.
7. Make sure any unused seat belt that a child can reach is buckled.

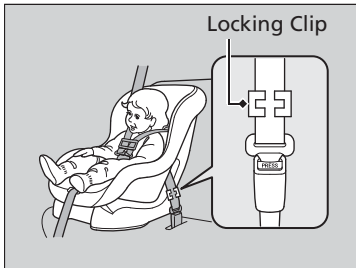

If your child restraint system does not come with a mechanism that secures the belt, install a locking clip on the seat belt.

After going through the step 1 and 2, pull up the shoulder part of the belt and make sure there is no slack in the lap portion.

3. Tightly grasp the belt near the latch plate. Pinch both parts of the belt together so they do not slip through the latch plate. Unbuckle the seat belt.
4. Install the locking clip as shown in the image. Position the clip as close as possible to the latch plate.
5. Insert the latch plate into the buckle. Go to step 6 and 7.



## ■ Adding Security with a Tether

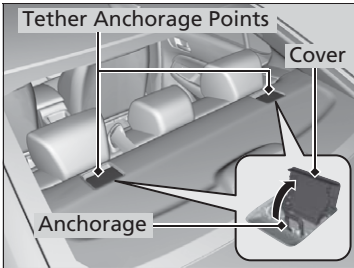

A tether anchorage point is provided behind each of rear outer seating position. If you have a child restraint system that comes with a tether but can be installed with a seat belt, the tether may be used for additional security.

1. Locate the appropriate tether anchorage point.

## ▣ Adding Security with a Tether

**WARNING:** Child restraint anchorages are designed to withstand only those loads imposed by correctly fitted child restraints. Under no circumstances are they to be used for adult seat belts, harnesses or for attaching other items or equipment to the vehicle.

Always use a tether for front-facing child restraint system when using the seat belt or lower anchorages.

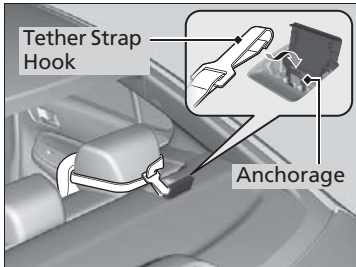
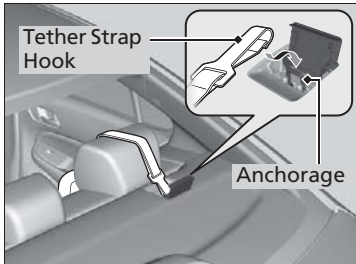

2. Route the tether strap as shown, and secure the tether strap hook to the anchorage. Make sure the strap is not twisted.
3. Secure the tether strap hook to the anchorage.
4. Tighten the tether strap as instructed by the child restraint system manufacturer.

## Safety of Larger Children

### ■ Protecting Larger Children

The following pages give instructions on how to check proper seat belt fit, what kind of booster seat to use if one is needed, and important precautions for a child who must sit in front.

### ■ Checking Seat Belt Fit

When a child is too big for a child restraint system, secure the child in a rear seat using the lap/shoulder seat belt. Have the child sit upright and all the way back, then answer the following questions.

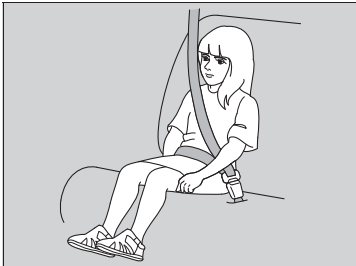

#### ■ Checklist

- Do the child's knees bend comfortably over the edge of the seat?
- Does the shoulder belt cross between the child's neck and arm?
- Is the lap part of the seat belt as low as possible, touching the child's thighs?
- Will the child be able to stay seated like this for the whole trip?

If you answer yes to all these questions, the child is ready to wear the lap/shoulder seat belt correctly. If you answer no to any question, the child needs to ride on a booster seat until the seat belt fits properly without a booster seat.

### ▶▶ Safety of Larger Children

#### ⚠ WARNING

Allowing a child aged 12 or under to sit in front can result in injury or death if the passenger's front airbag inflates.

If a larger child must ride in front, move the vehicle seat as far to the rear as possible, have the child sit up properly and wear the seat belt properly, using a booster seat if needed.

## Booster Seats



If a lap/shoulder seat belt cannot be used properly, position the child in a booster seat in the rear seat. For the child's safety, check that the child meets the booster seat manufacturer's recommendations.

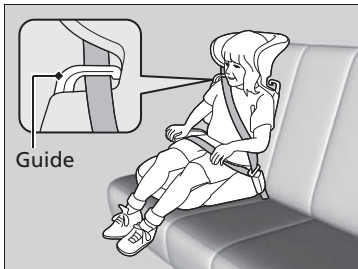

A backrest is available for a specific booster seat. Install the backrest to the booster seat and adjust it to the vehicle seat according to the booster seat manufacturer's instructions. Make sure the seat belt is properly routed through the guide at the shoulder of the backrest and the belt does not touch and cross the child's neck.

## Booster Seats

When installing a booster seat, make sure to read the instructions that came with it, and install the seat accordingly.

There are high- and low-type booster seats. Choose a booster seat that allows the child to wear the seat belt correctly.

We recommend a booster seat with a backrest as it is easier to adjust the shoulder belt.

## ■ Protecting Larger Children - Final Checks

Your vehicle has a rear seat where children can be properly restrained. If you ever have to carry a group of children, and a child must ride in front:

- Make sure you read and fully understand the instructions and safety information in this manual.
- Move the front passenger seat as far back as possible.
- Have the child sit upright and well back in the seat.
- Check that the seat belt is properly positioned so that the child is secure in the seat.

## ■ Monitoring child passengers

We strongly recommend that you keep an eye on child passengers. Even older, more mature children sometimes need to be reminded to fasten their seat belts and sit up properly.

## Carbon Monoxide Gas

The engine exhaust from this vehicle contains carbon monoxide, a colourless, odourless, and highly toxic gas. As long as you properly maintain your vehicle, carbon monoxide gas will not get into the interior.

### ■ Have the exhaust system inspected for leaks whenever

- The exhaust system is making an unusual noise.
- The exhaust system may have been damaged.
- The vehicle is raised for an oil change.

When you operate a vehicle with the boot open, airflow can pull exhaust gas into the interior and create a hazardous condition. If you must drive with the boot open, open all the windows and set the cooling system or climate control system as shown below.

1. Select the fresh air mode.
2. Select the  mode.
3. Set the fan speed to high.
4. Set the temperature control to a comfortable setting.

Adjust the cooling system or climate control system in the same manner if you sit in your parked vehicle with the engine running.

### Carbon Monoxide Gas

## WARNING

Carbon monoxide gas is toxic.

Breathing it can cause unconsciousness and even kill you.

Avoid any enclosed areas or activities that expose you to carbon monoxide.

An enclosed area such as a garage can quickly fill up with carbon monoxide gas.

Do not run the engine with the garage door closed. Even when the garage door is open, drive out of the garage immediately after starting the engine.

## Label Locations

These labels are in the locations shown. They warn you of potential hazards that can cause serious injury or death. Read these labels carefully.

If a label comes off or becomes hard to read, contact a dealer for a replacement.

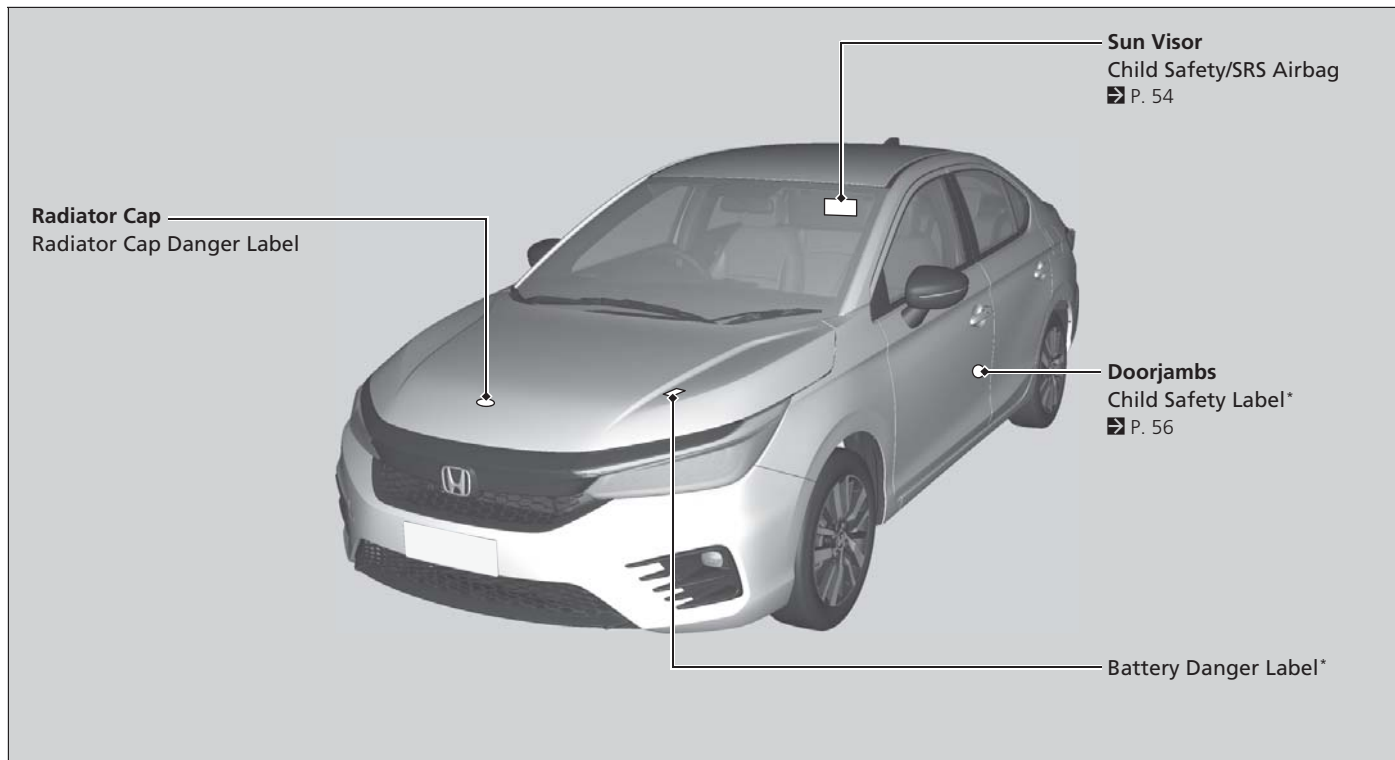

\* Not available on all models





# Instrument Panel



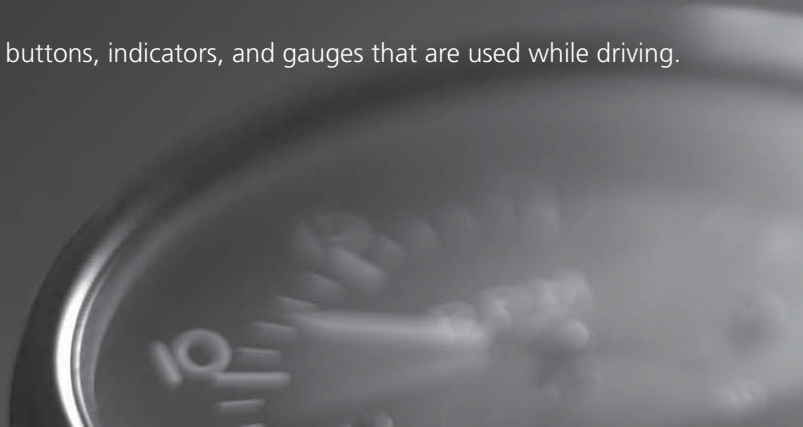



















This chapter describes the buttons, indicators, and gauges that are used while driving.



<b>Indicators</b> .....	88
<b>Gauges and Displays</b> .....	104
Gauges .....	104
Information Display* .....	106
Driver Information Interface* .....	108

\* Not available on all models























Indicators come on/blink depending on the condition of the vehicle. Messages may display on the driver information interface\* at the same time. Please take the appropriate action outlined in the message, such as contacting a dealer.

 *1	Parking Brake and Brake System Indicator (Red) → P. 90	 *2	Shift Position Indicator* → P. 92	 *1	High Temperature Indicator (Red)*/ Low Temperature Indicator (Blue) → P. 94
 *1	Brake System Indicator (Amber) → P. 90	 *3	Seat Belt Reminder Indicator → P. 93	 *1	Door and Boot Open Indicator* → P. 95
 *1	Low Oil Pressure Indicator* → P. 91	 *1	Rear Seat Belt Reminder Indicators* → P. 93	 *1	Vehicle Stability Assist (VSA) System Indicator → P. 95
 *1	Malfunction Indicator Lamp → P. 91	 *1	Low Fuel Indicator → P. 93	 *1	VSA <b>OFF</b> Indicator → P. 95
 *1	Charging System Indicator → P. 91	 *1	Anti-lock Brake System (ABS) Indicator → P. 94	 *1	Electric Power Steering (EPS) System Indicator → P. 96
 *2	Transmission System Indicator* → P. 92	 *1	Supplemental Restraint System Indicator → P. 94	 *1	Turn Signal and Hazard Warning Indicators → P. 96
 *3	M (7-speed manual shift mode) Indicator*/ Shift Indicator* → P. 92	 *1		 *1	High-Beam Indicator → P. 96
 *2					
 *3					



\*1: When you set the power mode to ON, these indicators come on to indicate that system checks are being performed. They go off a few seconds later or after the engine has started. If an indicator does not come on or turn off, there may be a malfunction in the corresponding system. To resolve the issue, follow the instructions in the owner's manual.



\*2: Models with information display

\*3: Models with driver information interface



	Lights On Indicator	→ P. 96		<sup>*2</sup> <b>CRUISE CONTROL</b>	<b>CRUISE CONTROL</b> Indicator*	→ P. 98		Diesel Particulate Filter (DPF) Indicator*	→ P. 101
	Fog Light Indicator*	→ P. 96		<sup>*3</sup> <b>CRUISE CONTROL</b>				Glow Plugs Indicator*	→ P. 102
	<sup>*1</sup> Light Control Indicator*	→ P. 97		<sup>*1</sup>	Starter System Indicator*	→ P. 99		<sup>*1</sup> PGM-FI Indicator*	→ P. 102
	<sup>*1</sup> Keyless Access System Indicator*	→ P. 98			Rotate Wheel Indicator*	→ P. 99		Water in Fuel Indicator*	→ P. 102
	ECON Mode Indicator*	→ P. 98			Shift to Park Indicator*	→ P. 99		<b>NO KEY</b> <b>NO KEY</b> Indicator*	→ P. 103
<b>ECO</b>	ECO Indicator*	→ P. 98		<sup>*1</sup>	Low Tyre Pressure/Deflation Warning System Indicator*	→ P. 100		<b>KEY BATT</b> Indicator*	→ P. 103
	<sup>*2</sup> <b>CRUISE MAIN</b> Indicator*	→ P. 98		<sup>*1</sup>	Speed Alarm Indicator*	→ P. 101		Immobilizer System Indicator	→ P. 97
	<sup>*3</sup> <b>CRUISE MAIN</b> Indicator*				System Message Indicator*	→ P. 101		Security System Alarm Indicator	→ P. 97

\*1: When you set the power mode to ON, these indicators come on to indicate that system checks are being performed. They go off a few seconds later or after the engine has started. If an indicator does not come on or turn off, there may be a malfunction in the corresponding system. To resolve the issue, follow the instructions in the owner's manual.  
 \*2: Models with information display  
 \*3: Models with driver information interface

Indicator	Name	On/Blinking	Explanation
 (Red)	Parking Brake and Brake System Indicator (Red)	<ul style="list-style-type: none"> <li>• Comes on when the parking brake is applied, and goes off when it is released.</li> </ul>	<ul style="list-style-type: none"> <li>• The beeper sounds and the indicator comes on if you drive with the parking brake not fully released.</li> </ul>
		<ul style="list-style-type: none"> <li>• Comes on when the brake fluid level is low.</li> </ul>	<ul style="list-style-type: none"> <li>• <b>Comes on while driving</b> - Make sure the parking brake is released. Stop in a safe place and check the brake fluid level.                      ➤ <b>What to do when the indicator comes on while driving</b> P. 343</li> </ul>
		<ul style="list-style-type: none"> <li>• Comes on if there is a problem with the brake system.</li> </ul>	<ul style="list-style-type: none"> <li>• <b>Comes on along with the ABS indicator</b> - Have your vehicle checked by a dealer.                      ➤ <b>If the Brake System Indicator (Red) Comes On</b> P. 343</li> </ul>
 (Amber)	Brake System Indicator (Amber)	<ul style="list-style-type: none"> <li>• Comes on if there is a problem with a system related to braking other than the conventional brake system.</li> </ul>	<ul style="list-style-type: none"> <li>• <b>Comes on while driving</b> - Have your vehicle checked by a dealer.</li> <li>• With this indicator on, your vehicle still has normal braking ability.</li> </ul>



Indicator	Name	On/Blinking	Explanation
	Low Oil Pressure Indicator*	<ul style="list-style-type: none"> <li>Comes on when the engine oil pressure is low.</li> </ul>	<ul style="list-style-type: none"> <li><b>Comes on while driving</b> - Immediately stop in a safe place.                             <ul style="list-style-type: none"> <li>➤ <b>If the Low Oil Pressure Indicator Comes On</b> P. 340</li> </ul> </li> <li><b>Diesel models</b> <ul style="list-style-type: none"> <li>➤ <b>Starting the Engine</b> P. 206</li> </ul> </li> </ul>
	Malfunction Indicator Lamp	<ul style="list-style-type: none"> <li>Comes on if there is a problem with the emissions control systems.</li> <li><b>Petrol models</b></li> <li>Blinks when a misfire in the engine's cylinders is detected.</li> </ul>	<ul style="list-style-type: none"> <li>➤ <b>If the Malfunction Indicator Lamp Comes On or Blinks</b> P. 343</li> </ul>
	Charging System Indicator	<ul style="list-style-type: none"> <li>Comes on when the battery is not charging.</li> </ul>	<ul style="list-style-type: none"> <li>Stop in a safe place and have your vehicle checked by a dealer immediately.                             <ul style="list-style-type: none"> <li>➤ <b>If the Charging System Indicator Comes On</b> P. 342</li> </ul> </li> </ul>

\* Not available on all models





Indicator	Name	On/Blinking	Explanation
	Transmission System Indicator*	<ul style="list-style-type: none"> <li>Blinks if the transmission system has a problem.</li> </ul>	<ul style="list-style-type: none"> <li><b>Blinks while driving</b> - Avoid sudden starts and acceleration and have your vehicle checked by a dealer immediately.</li> </ul>
		<p><b>Models with paddle shifters</b></p> <ul style="list-style-type: none"> <li>Blinks if the transmission system has a problem and the paddle shifters cannot be used.</li> </ul>	<ul style="list-style-type: none"> <li>Have your vehicle checked by a dealer immediately.</li> </ul>
	M (7-speed manual shift mode) Indicator*/Shift Indicator*	<ul style="list-style-type: none"> <li>Comes on when the 7-speed manual shift mode is applied.</li> </ul>	<p>➤ <b>7-Speed Manual Shift Mode</b> P. 217</p>
	Shift Position Indicator*	<ul style="list-style-type: none"> <li>Indicates the current shift position.</li> </ul>	<p>➤ <b>Shifting</b> P. 215</p>

\*1:Models with information display





\*2:Models with driver information interface

Indicator	Name	On/Blinking	Explanation
	Seat Belt Reminder Indicator	<ul style="list-style-type: none"> <li>• Comes on if you are not wearing a seat belt when you set the power mode to ON.</li> <li>• If the front passenger is not wearing a seat belt, the indicator comes on a few seconds later.</li> <li>• Blinks while driving if you and/or the front passenger has not fastened a seat belt. The beeper sounds and the indicator blinks at regular intervals.</li> </ul>	<ul style="list-style-type: none"> <li>• The beeper stops and the indicator goes off when you and the front passenger fasten their seat belts.</li> <li>• <b>Stays on after you and/or the front passenger has fastened the seat belt(s)</b> - A detection error may have occurred in the sensor. Have your vehicle checked by a dealer. <ul style="list-style-type: none"> <li>➤ <b>Seat Belt Reminder</b> P. 36</li> </ul> </li> </ul>
<p>REAR</p> 	Rear Seat Belt Reminder Indicators*	<ul style="list-style-type: none"> <li>• Comes on if the rear seat belts are unfastened when you set the power mode to ON.</li> <li>• Blinks and the beeper sounds while driving if the rear seat belts are unfastened.</li> </ul>	<ul style="list-style-type: none"> <li>• Goes off when the rear passengers have fastened their seat belts. <ul style="list-style-type: none"> <li>➤ <b>Seat Belt Reminder</b> P. 36</li> </ul> </li> </ul>
	Low Fuel Indicator	<ul style="list-style-type: none"> <li>• Comes on when the fuel reserve is running low (approximately 6.0 Litres left).</li> <li>• Blinks if there is a problem with the fuel gauge.</li> </ul> <p><b>Diesel models</b></p> <ul style="list-style-type: none"> <li>• The fuel gauge dot disappeared.</li> </ul>	<ul style="list-style-type: none"> <li>• <b>Comes on</b> - Refuel your vehicle as soon as possible.</li> <li>• <b>Blinks</b> - Have your vehicle checked by a dealer.</li> <li>• Even if you depress the accelerator pedal, the engine speed (RPM) will not increase.</li> <li>• Refuel your vehicle as soon as possible then restart the engine. The vehicle speed limit will be released when refueling 10.0 Litres or more. <ul style="list-style-type: none"> <li>➤ <b>Refueling</b> P. 246</li> </ul> </li> </ul>





\* Not available on all models





Indicator	Name	On/Blinking	Explanation
	Anti-lock Brake System (ABS) Indicator	<ul style="list-style-type: none"> <li>Comes on if there is a problem with the ABS.</li> </ul>	<ul style="list-style-type: none"> <li><b>Stays on constantly</b> - Have your vehicle checked by a dealer. With this indicator on, your vehicle still has normal braking ability but no anti-lock function.                             <ul style="list-style-type: none"> <li>➤ <b>Anti-lock Brake System (ABS)</b> P. 237</li> </ul> </li> </ul>
	Supplemental Restraint System Indicator	<ul style="list-style-type: none"> <li>Comes on if a problem with any of the following is detected:                             <ul style="list-style-type: none"> <li>- Supplemental restraint system</li> <li>- Side airbag system</li> <li>- Side curtain airbag system*</li> <li>- Seat belt tensioner</li> </ul> </li> </ul>	<ul style="list-style-type: none"> <li><b>Stays on constantly</b> - Have your vehicle checked by a dealer.</li> </ul>
	High Temperature Indicator (Red)*	<ul style="list-style-type: none"> <li>Blinks when the engine coolant temperature goes up, and stays on if the temperature continues to rise.</li> </ul>	<ul style="list-style-type: none"> <li>Comes on blue when the engine coolant temperature is low.</li> <li><b>Blinks while driving</b> - Drive slowly to prevent overheating.</li> <li><b>Stays on while driving</b> - Immediately stop in a safe place and allow the engine to cool.                             <ul style="list-style-type: none"> <li>➤ <b>Overheating</b> P. 338</li> </ul> </li> </ul>
	Low Temperature Indicator (Blue)	<ul style="list-style-type: none"> <li>Comes on when the engine coolant temperature is low.</li> </ul>	<ul style="list-style-type: none"> <li>If the indicator stays on after the engine has reached normal operating temperature, there may be a problem with the temperature sensors. Have your vehicle inspected by a dealer.</li> </ul>









Indicator	Name	On/Blinking	Explanation
	Door and Boot Open Indicator*	<ul style="list-style-type: none"> <li>• Comes on if any door or the boot is not completely closed.</li> <li>• The beeper sounds and the indicator comes on if the boot or any door is opened while driving.</li> </ul>	<ul style="list-style-type: none"> <li>• Goes off when the boot and all doors are closed.</li> </ul>
	Vehicle Stability Assist (VSA) System Indicator	<ul style="list-style-type: none"> <li>• Blinks when VSA is active.</li> <li>• Comes on if there is a problem with the VSA system, brake assist system, hill start assist system.</li> <li>• Comes on if the VSA system is deactivated temporarily after the battery has been disconnected, then re-connected.</li> </ul>	<p>—</p> <ul style="list-style-type: none"> <li>• <b>Stays on constantly</b> - Have your vehicle checked by a dealer.   <b>Vehicle Stability Assist (VSA) System</b>                      P. 228</li> <li>• Drive a short distance at more than 20 km/h. The indicator should go off. If it does not, have your vehicle checked by a dealer.</li> </ul>
	Vehicle Stability Assist (VSA) <b>OFF</b> Indicator	<ul style="list-style-type: none"> <li>• Comes on when you partially disable VSA.</li> <li>• Comes on if the VSA system is deactivated temporarily after the battery has been disconnected, then re-connected.</li> </ul>	<ul style="list-style-type: none"> <li>•  <b>VSA On and Off</b> P. 229</li> <li>• Drive a short distance at more than 20 km/h. The indicator should go off. If it does not, have your vehicle checked by a dealer.</li> </ul>

\* Not available on all models

Indicator	Name	On/Blinking	Explanation
	Electric Power Steering (EPS) System Indicator	<ul style="list-style-type: none"> <li>Comes on if there is a problem with the EPS System.</li> </ul>	<ul style="list-style-type: none"> <li><b>Comes on while driving</b> - Immediately stop in a safe place.</li> <li><b>Stays on constantly</b> - Have your vehicle checked by a dealer.                             <ul style="list-style-type: none"> <li>➤ <b>If the Electric Power Steering (EPS) System Indicator Comes On</b> P. 344</li> </ul> </li> </ul>
	Turn Signal and Hazard Warning Indicators	<ul style="list-style-type: none"> <li>Blinks when you operate the turn signal lever.</li> <li>Blink along with all turn signals when you press the hazard warning button.</li> </ul>	<ul style="list-style-type: none"> <li><b>Does not blink or blinks rapidly</b> <ul style="list-style-type: none"> <li>➤ <b>Replacing Light Bulbs</b> P. 282, 285, 286</li> </ul> </li> </ul>
		<ul style="list-style-type: none"> <li>Blink along with all turn signals when you depress the brake pedal while the high speed driving.</li> </ul>	<ul style="list-style-type: none"> <li>➤ <b>Emergency Stop Signal</b> P. 239</li> </ul>
	High-Beam Indicator	<ul style="list-style-type: none"> <li>Comes on when the high beam headlights are on.</li> </ul>	—
	Lights On Indicator	<ul style="list-style-type: none"> <li>Comes on when the position, tail, and other external lights are on.</li> </ul>	<ul style="list-style-type: none"> <li>➤ <b>Light Switches</b> P. 161</li> </ul>
	Fog Light Indicator*	<ul style="list-style-type: none"> <li>Comes on when the fog lights are on.</li> </ul>	<ul style="list-style-type: none"> <li>➤ <b>Fog Lights*</b> P. 163</li> </ul>



Indicator	Name	On/Blinking	Explanation
	Light Control Indicator*	<p><b>Models with automatic lighting control</b></p> <ul style="list-style-type: none"> <li>Comes on if there is a problem with the automatic lighting control system.</li> </ul>	<ul style="list-style-type: none"> <li><b>Comes on while driving</b> - Manually turn the lights on, and have your vehicle checked by a dealer.</li> </ul>
		<p><b>Models with LED headlights</b></p> <ul style="list-style-type: none"> <li>Comes on if there is a problem with the headlights.</li> </ul>	<ul style="list-style-type: none"> <li><b>Comes on while driving</b> - The headlights may not be on. When conditions allow you to drive safely, have your vehicle checked by a dealer as soon as possible.</li> </ul>
	Immobilizer System Indicator	<ul style="list-style-type: none"> <li>Blinks if the immobilizer system cannot recognise the key information.</li> </ul>	<ul style="list-style-type: none"> <li><b>Blinks</b> - You cannot start the engine. Set the power mode to VEHICLE OFF, then select the ON mode again.</li> <li><b>Repeatedly blinks</b> - The system may be malfunctioning. Have your vehicle checked by a dealer.</li> <li>Do not attempt to alter this system or add other devices to it. Electrical problems can occur.</li> </ul>
	Security System Alarm Indicator	<ul style="list-style-type: none"> <li>Blinks when the security system alarm has been set.</li> </ul>	<p> <b>Security System Alarm</b> P. 149</p>

\* Not available on all models

Indicator	Name	On/Blinking	Explanation
	Keyless Access System Indicator*	<ul style="list-style-type: none"> <li>Comes on as soon as a problem is detected in the keyless access system* or keyless starting system.</li> </ul>	<ul style="list-style-type: none"> <li><b>Stays on constantly or does not come on at all</b> - Have your vehicle checked by a dealer.</li> </ul>
	ECON Mode Indicator*	<ul style="list-style-type: none"> <li>Comes on when the ECON mode is on.</li> </ul>	➔ <b>ECON Mode*</b> P. 221
ECO	ECO Indicator*	<ul style="list-style-type: none"> <li>Comes on while the engine is operating in its most economical range.</li> </ul>	—
 *1  *2	<b>CRUISE MAIN</b> Indicator*	<ul style="list-style-type: none"> <li>Comes on when you press the <b>CRUISE</b> button.</li> </ul>	➔ <b>Cruise Control*</b> P. 222
 *1  *2	<b>CRUISE CONTROL</b> Indicator*	<ul style="list-style-type: none"> <li>Comes on if you have set a speed for cruise control.</li> </ul>	➔ <b>Cruise Control*</b> P. 222





\*1:Models with information display

\*2:Models with driver information interface



Indicator	Name	On/Blinking	Explanation
	Starter System Indicator*	<ul style="list-style-type: none"> <li>Comes on if the starting system has a problem.</li> </ul>	<ul style="list-style-type: none"> <li>As a temporary measure, press and hold the <b>ENGINE START/STOP</b> button for 15 seconds while pressing the brake pedal and clutch pedal (manual transmission), and manually start the engine. Have your vehicle checked by a dealer.</li> </ul>
	Rotate Wheel Indicator*	<ul style="list-style-type: none"> <li>Comes on when the steering wheel is locked.</li> </ul>	<ul style="list-style-type: none"> <li>Move the steering wheel left and right while pressing the <b>ENGINE START/STOP</b> button.</li> </ul>
	Shift to Park Indicator*	<ul style="list-style-type: none"> <li>Blinks if you push the <b>ENGINE START/STOP</b> button to turn the engine off without the shift lever in <b>P</b>.</li> </ul>	<ul style="list-style-type: none"> <li>Push the <b>ENGINE START/STOP</b> button twice after moving the shift lever to <b>P</b>.</li> </ul>

\* Not available on all models



Indicator	Name	On/Blinking	Explanation
	Low Tyre Pressure/Deflation Warning System Indicator*	<ul style="list-style-type: none"> <li>• May come on briefly if the power mode is set to ON and the vehicle is not moved within 45 seconds, to indicate the initialise process is not yet complete.</li> <li>• Comes on and stays on when:                             <ul style="list-style-type: none"> <li>- One or more tyres' pressures are determined to be significantly low.</li> <li>- The system has not been initialised.</li> </ul> </li> </ul>	<ul style="list-style-type: none"> <li>• <b>Comes on while driving</b> - Stop in a safe place, check tyre pressures, and inflate the tyre(s) if necessary.</li> <li>• <b>Stays on after the tyres are inflated to the recommended pressures</b> - The system needs to be initialised.                             <ul style="list-style-type: none"> <li>▣ <b>Deflation Warning System Initialisation</b> P. 232</li> </ul> </li> </ul>
		<ul style="list-style-type: none"> <li>• Blinks for about one minute, and then stays on if there is a problem with the deflation warning system, or when a compact spare tyre* is temporarily installed.</li> </ul>	<ul style="list-style-type: none"> <li>• <b>Blinks and remains on</b> - Have your vehicle checked by a dealer. If the vehicle is fitted with a compact spare tyre*, get your regular tyre repaired or replaced and put back on your vehicle as soon as you can.</li> </ul>
		<ul style="list-style-type: none"> <li>• Comes on if the deflation warning system is deactivated temporarily after the battery has been disconnected, then re-connected.</li> </ul>	<ul style="list-style-type: none"> <li>• Drive a short distance at more than 20 km/h. The indicator should go off. If it does not, have your vehicle checked by a dealer.</li> </ul>

Indicator	Name	On/Blinking	Explanation
	Speed Alarm Indicator*	<ul style="list-style-type: none"> <li>Comes on when your vehicle speed exceeds 80 km/h. A reminder tone sounds about every two minutes.</li> <li>Blinks when your vehicle speed exceeds 120 km/h. A reminder tone sounds continuously.</li> </ul>	<ul style="list-style-type: none"> <li>This indicator keeps illuminating while your vehicle speed is faster than 80 km/h.</li> <li>This indicator keeps blinking while your vehicle speed is faster than 120 km/h.</li> </ul>
	System Message Indicator*	<ul style="list-style-type: none"> <li>Comes on along with a beep when a problem is detected. A system message on the driver information interface appears at the same time.</li> </ul>	<ul style="list-style-type: none"> <li>While the indicator is on, press the  (home) button, and select <b>Information</b> to see the message again.                             <ul style="list-style-type: none"> <li>➤ <b>Switching the Display</b> P. 108</li> </ul> </li> <li>Refer to the Indicators information in this chapter when a system message appears on the driver information interface. Respond to the message accordingly.</li> <li>The driver information interface does not return to the normal screen unless the warning is cancelled, or the left selector wheel is pressed.</li> </ul>
	Diesel Particulate Filter (DPF) Indicator*	<ul style="list-style-type: none"> <li>Blinks when you need to regenerate the diesel particulate filter (DPF). This is not a DPF failure.</li> <li>Comes on when you ignore it blinking. Particulate matter has started clogging the DPF system. This is a problem.</li> </ul>	<ul style="list-style-type: none"> <li>➤ <b>Diesel Particulate Filter (DPF)</b> P. 277</li> <li>Have your vehicle checked by a dealer.</li> </ul>

\* Not available on all models

Indicator	Name	On/Blinking	Explanation
	Glow Plugs Indicator*	<ul style="list-style-type: none"> <li>• Comes on for a while when you set the power mode to ON under the extremely low engine coolant temperature condition, then goes off.</li> </ul>	<ul style="list-style-type: none"> <li>• <b>Stays on</b> - The engine is cold. The engine can be started once the indicator goes off.                             <ul style="list-style-type: none"> <li>➤ <b>Starting the Engine</b> P. 206</li> </ul> </li> <li>• If you still find it hard to start the engine, have your vehicle inspected by your dealer.</li> </ul>
		<ul style="list-style-type: none"> <li>• Comes on if the engine is cold when you press the <b>ENGINE START/STOP</b> button.</li> </ul>	<ul style="list-style-type: none"> <li>• The engine automatically starts when the indicator goes off.                             <ul style="list-style-type: none"> <li>➤ <b>Starting the Engine</b> P. 206</li> </ul> </li> </ul>
	PGM-FI Indicator*	<ul style="list-style-type: none"> <li>• Comes on while driving if there is a problem with the engine control system.</li> </ul>	<ul style="list-style-type: none"> <li>➤ <b>If the PGM-FI Indicator Comes On</b> P. 346</li> </ul>
		<ul style="list-style-type: none"> <li>• Comes on if you do not use the proper fuel for the climate or regional conditions.</li> </ul>	<ul style="list-style-type: none"> <li>• Use of inadequate fuel may reduce engine power.                             <ul style="list-style-type: none"> <li>➤ <b>Fuel recommendation</b> P. 247</li> </ul> </li> </ul>
	Water in Fuel Indicator*	<ul style="list-style-type: none"> <li>• Comes on when water has accumulated in the fuel system.</li> <li>• Comes on if you have parked your vehicle for an extended period.</li> </ul>	<ul style="list-style-type: none"> <li>• Have a dealer drain off the water from the system as soon as possible. Accumulated water may cause damage to the fuel system.</li> <li>• Have your vehicle checked by a dealer.</li> </ul>



Indicator	Name	On/Blinking	Explanation
	<b>NO KEY</b> Indicator*	<ul style="list-style-type: none"> <li>Comes on when you close the door with the power mode in ON without the keyless remote inside the vehicle.</li> </ul>	<ul style="list-style-type: none"> <li>The indicator goes off when you bring the keyless remote back inside the vehicle, and close the door.</li> </ul>
	<b>KEY BATT</b> Indicator*	<ul style="list-style-type: none"> <li>Comes on when the keyless remote's battery becomes weak.</li> </ul>	<ul style="list-style-type: none"> <li>Replace the battery as soon as possible.   <b>Replacing the Button Battery</b> P. 306</li> </ul>

\* Not available on all models

## Gauges

Gauges include the speedometer, fuel gauge, and other related indicators. They are displayed when the power mode is in ON.

### ■ Speedometer

Displays your driving speed in km/h.

### ■ Fuel Gauge

Displays the amount of fuel left in the fuel tank.

### ■ Tachometer

Shows the number of engine revolutions per minute.

#### Models with information display

### ■ Instant Fuel Economy

Shows the instant fuel economy as a bar graph in km/l\* or l/100 km\*.

#### » Fuel Gauge

##### NOTICE

You should refuel when the reading approaches [E]. Running out of fuel can cause the engine to misfire, damaging the catalytic converter.

The actual amount of remaining fuel may differ from the fuel gauge reading.

#### » Instant Fuel Economy

##### Diesel models

You may temporarily find the instant fuel economy lower than in normal driving while the DPF (diesel particulate filter) system is in operation.

## ■ Outside Temperature

Shows the outside temperature in Celsius.

If the outside temperature has been below 3°C at the time you set the power mode to ON, the outside temperature indicator blinks for 10 seconds.

### ■ Adjusting the outside temperature display

Adjust the temperature reading up to ±3°C if the temperature reading seems incorrect.

#### Models with information display

1. Set the power mode to ON.
2. Press and hold the **TRIP/CLOCK** button for 10 seconds or more while the outside temperature is shown on the information display.
  - ▶ The information display goes into temperature adjustment mode. The display starts showing from -3°C to +3°C.
3. Release the **TRIP/CLOCK** button when the right adjustment amount is shown.
  - ▶ The adjustment is complete.

## ■ Clock

Shows the clock.

#### Models with driver information interface

## ■ Odometer

Shows the total number of kilometres that your vehicle has accumulated.

### ⌘ Outside Temperature

The temperature sensor is in the front bumper. Road heat and exhaust from another vehicle can affect the temperature reading when your vehicle speed is less than 30 km/h.

It may take several minutes for the display to be updated after the temperature reading has stabilised.

#### Models with driver information interface

You can adjust the temperature reading.

➤ **Settings** P. 116

### ⌘ Clock

You can adjust the time manually or change the clock display to show the 12 hour clock or 24 hour clock on the information display\* or driver information interface\*.

➤ **Settings** P. 116

➤ **Clock** P. 124

\* Not available on all models

## Information Display\*

The information display shows the odometer, trip meter, and other gauges.

### ■ Switching the Display

Press the **TRIP/CLOCK** button to change the display.

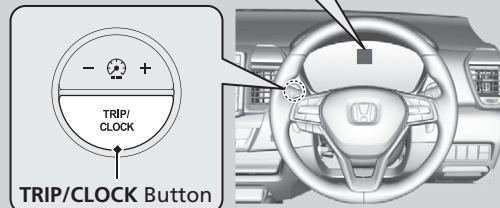
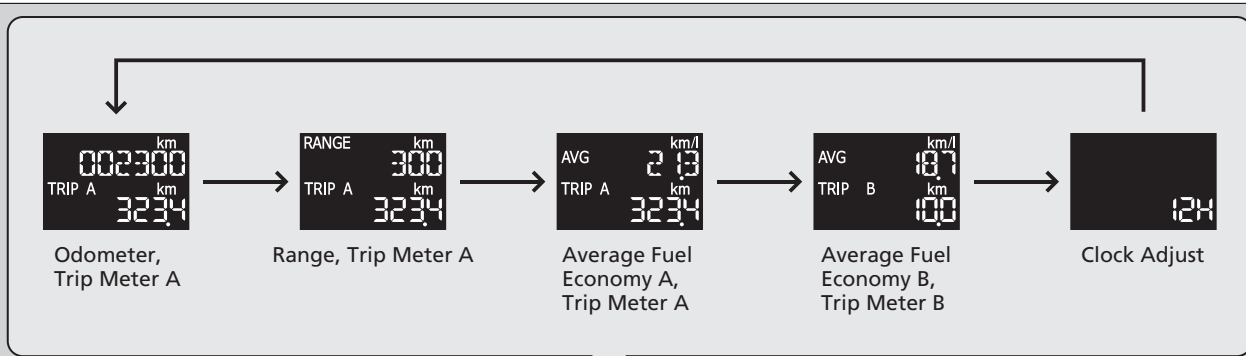

## ■ Odometer

Shows the total number of kilometres that your vehicle has accumulated.

## ■ Trip Meter

Shows the total number of kilometres driven since the last reset. Meters A and B can be used to measure two separate trips.

### ■ Resetting a trip meter

To reset a trip meter, display it, then press and hold the **TRIP/CLOCK** button. The trip meter is reset to **0.0**.

## ■ Average Fuel Economy

Shows the estimated average fuel economy of each trip meter in km/l\* or l/100 km\*. The display is updated at set intervals. When a trip meter is reset, the average fuel economy is also reset.

## ■ Range

Shows the estimated distance you can travel on the remaining fuel. This estimated distance is based on the vehicle's current fuel economy.

### ☒ Trip Meter

Switch between trip meter A and trip meter B by pressing the **TRIP/CLOCK** button.

\* Not available on all models

## Driver Information Interface \*

The driver information interface shows information such as the estimated travelable distance and fuel economy of the vehicle. It also displays messages such as warnings and other helpful information.

When a warning message displays, please check the message and contact a dealer and have the vehicle inspected if necessary. Please refer to the pages below if the “**Engine Oil Pressure Low**” or “**Engine Temperature Too Hot**” message is displayed.

➤ **If the Low Oil Pressure Warning Appears** P. 341

➤ **Overheating** P. 338

### Diesel models

Please refer to the page below if the “**Engine Control System Problem**” message is displayed.

➤ **If the PGM-FI Symbol Appears** P. 347

## Switching the Display

Press the  (home) button, then roll the left selector wheel to scroll to the content you want to see. Press the left selector wheel to see detailed information.

### Switching the Display

If a warning initially appears, you can - after reading it - press the  (home) button to proceed immediately to the content or to any other warning(s).

To go back to the home screen, press the  (home) button.

You can add or delete the meter contents.

➤ **Customize Display** P. 115

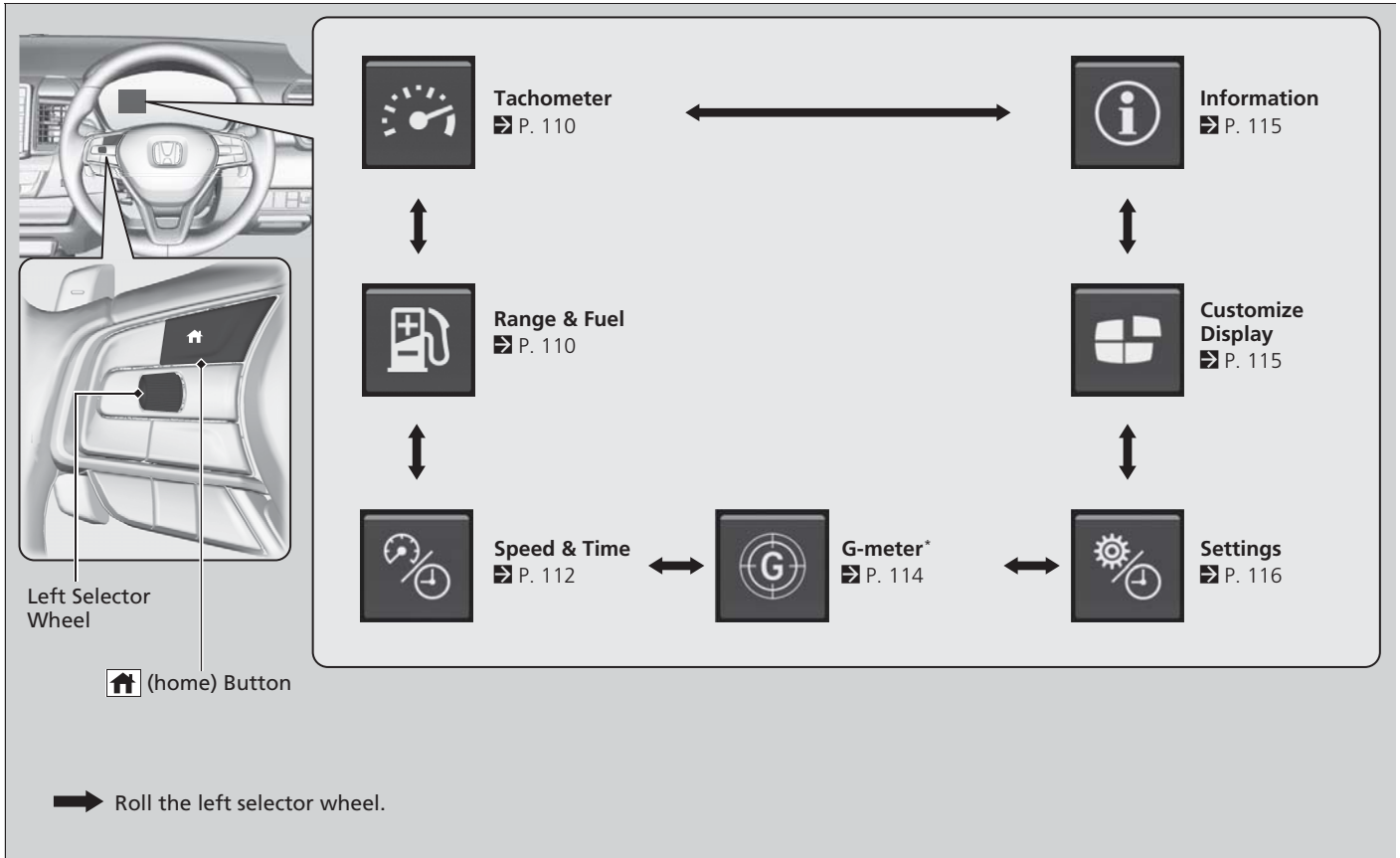

Instrument Panel

\* Not available on all models

## ■ Tachometer

Shows the number of engine revolutions per minute and other contents will hide.

## ■ Range/Fuel/Trip Meter

Roll the left selector wheel to switch between trip meter A and trip meter B.

**Left Selector Wheel**  
 Roll the left selector wheel.

**Trip Meter A**

- Range: 300 km
- AVG Fuel Economy: 12.4 km/k
- Instant Fuel Economy: 323.4 km
- Trip Meter: 323.4 km
- Reset button

**Trip Meter B**

- Range: 300 km
- AVG Fuel Economy: 14.0 km/l
- Trip Meter: 10.0 km
- Reset button

## ▶▶ Tachometer

The tachometer can be turned on and off using **Settings**.

▶ **Settings** P. 116

Even if you have turned off the tachometer using **Settings**, if **Tachometer** is selected on the driver information interface, it will change to a tachometer-only display.



### ■ Trip meter

Shows the total number of kilometres driven since the last reset. Meters A and B can be used to measure two separate trips.

### Resetting a trip meter

To reset the trip meter, display it, press the left selector wheel and then select **Reset**.

- ▶ The trip meter is reset to **0.0**.

### ■ Average fuel economy

Shows the estimated average fuel economy of each trip meter in km/l\* or l/100 km\*. The display is updated at set intervals. When a trip meter is reset, the average fuel economy is also reset.

### ■ Instant fuel economy

Shows the instant fuel economy as a bar graph in km/l\* or l/100 km\*.

### ■ Range

Shows the estimated distance you can travel on the remaining fuel. This estimated distance is based on the vehicle's current fuel economy.

#### ▶▶ Trip meter

Switch between trip meter A and trip meter B by rolling the left selector wheel.

#### ▶▶ Average fuel economy

You can change when to reset the average fuel economy.

- ➔ **Settings** P. 116

#### ▶▶ Instant fuel economy

##### Diesel models

You may temporarily find the instant fuel economy lower than in normal driving while the DPF (diesel particulate filter) system is in operation.

\* Not available on all models

## ■ Speed & Time

Roll the left selector wheel to switch between trip meter A and trip meter B.

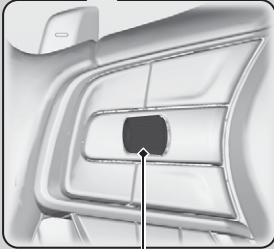
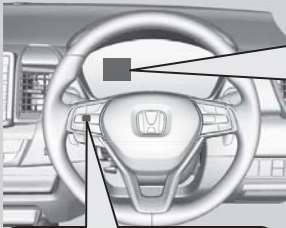

Left Selector Wheel

➔ Roll the left selector wheel.

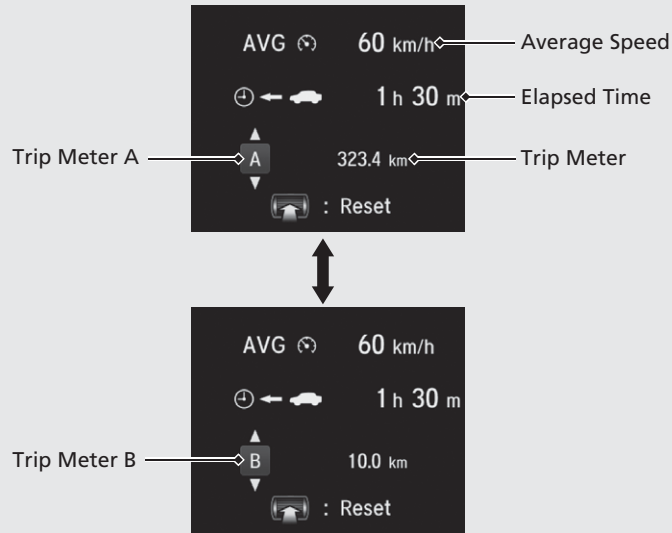

## ■ Trip meter

➤ Trip meter P. 111

## ■ Elapsed Time

Shows the time elapsed since the last time Trip A or Trip B was reset.

## ■ Average Speed

Shows the average speed in km/h since the last time Trip A or Trip B was reset.

### ⌘ Elapsed Time

You can change when to reset the elapsed time.

➤ Settings P. 116

### ⌘ Average Speed

You can change when to reset the average speed.

➤ Settings P. 116

### ■ G-meter\*

Displays the strength (G) and direction of the load that is applied to the vehicle during driving.

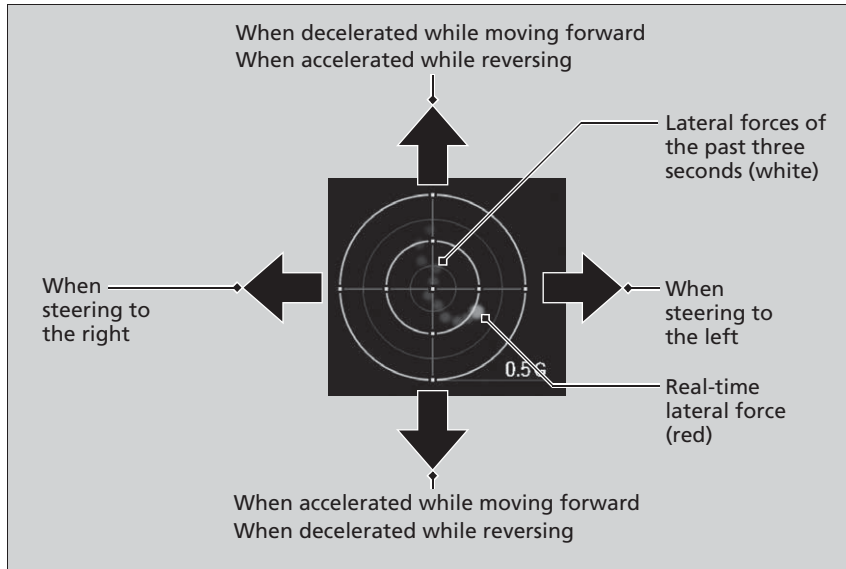

### ▣ G-meter\*

The meter does not display a lateral force larger than 0.5 G.

## ■ Customize Display

Change the settings to your liking.

### ■ Arrange content

You can choose which icons to display on the home screen.



1. Roll the left selector wheel to scroll to select **Customize Display**, then press the left selector wheel.
2. Roll the left selector wheel to scroll to select **Hide/Show**, then press the left selector wheel.

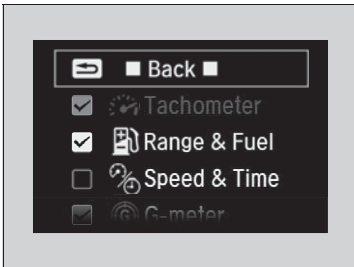

3. Roll the left selector wheel to scroll between icons, then press the left selector wheel to check or uncheck them.

## ■ Information

You can check if there are any active warning messages.

### ⌘ Customize Display

Icons that are gray cannot be removed from the home screen.



### ⌘ Information

If there are multiple warnings or informations, you can roll the left selector wheel to see other warnings.

## ■ Settings

Use the driver information interface to customize certain features.

### ■ How to customize

Select the  screen by pressing the  (home) button and rolling the left selector wheel while the power mode is in ON, and the vehicle is at a complete stop. Press the left selector wheel.

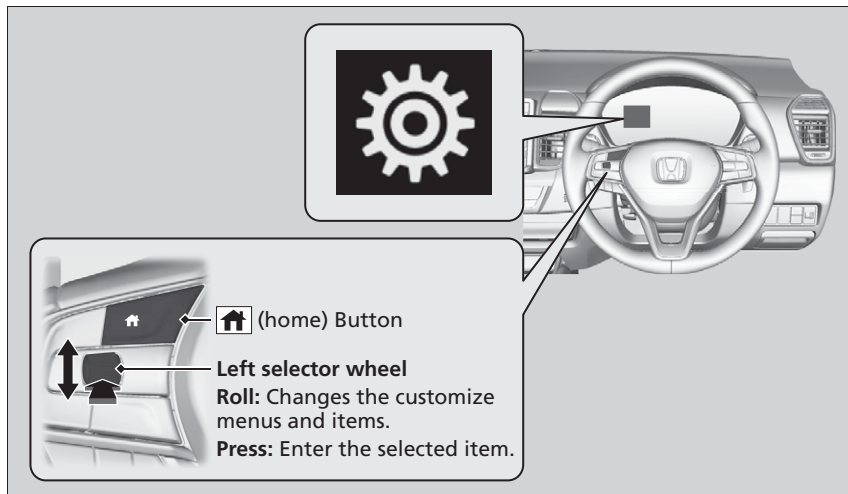

## ▶▶ Settings

To customize other features, roll the left selector wheel.

- ▶ **List of customizable options** P. 117
- ▶ **Example of customization settings** P. 121

### Continuously variable transmission models

When you customize settings, shift to **P**.

### Manual transmission models

When you customize settings, set the parking brake.

■ List of customizable options

Setup Group	Customizable Features	Description	Selectable Settings
<b>Deflation Warning System*</b>	—	Initialises the deflation warning system.	<b>Initialise/Cancel</b>
<b>Clock Setup</b>	<b>Clock Adjustment</b>	Adjusts the time. <input checked="" type="checkbox"/> <b>Adjusting the Clock</b> P. 124	—
	<b>Clock Display</b>	Sets time display 24 hour, 12 hour or off.	<b>24h/12h*<sup>1</sup>/OFF</b>
<b>Meter Setup</b>	<b>Adjust Outside Temp. Display</b>	Adjusts the temperature reading by a few degrees.	<b>-3°C ~ ±0°C*<sup>1</sup> ~ +3°C</b>
	<b>“Trip A” Reset Timing</b>	Changes the setting of how to reset trip meter A, average fuel economy A, average speed A, and elapsed time A.	<b>When Fully Refueled/When Ignition Is Turned OFF/Manual Reset*<sup>1</sup></b>
	<b>“Trip B” Reset Timing</b>	Changes the setting of how to reset trip meter B, average fuel economy B, average speed B, and elapsed time B.	<b>When Fully Refueled/When Ignition Is Turned OFF/Manual Reset*<sup>1</sup></b>
	<b>Alarm Volume Control</b>	Changes the alarm volume, such as buzzers, warnings, turn signal sound, and so on.	<b>Max/Mid*<sup>1</sup>/Min</b>
	<b>Fuel Efficiency Backlight</b>	Turns the ambient meter feature on and off.	<b>ON*<sup>1</sup>/OFF</b>
	<b>Tachometer</b>	Selects whether the tachometer is displayed on the driver information interface.	<b>ON*<sup>1</sup>/OFF</b>

\*1:Default Setting

\* Not available on all models

Setup Group	Customizable Features	Description	Selectable Settings
<b>Keyless Access Setup</b>	<b>Door Unlock Mode*</b>	Changes which doors unlock when you grab the driver's door handle.	<b>Driver Door Only*<sup>1</sup>/All Doors</b>
	<b>Keyless Access Beep Volume</b>	Changes the beep tone that sounds when you have a keyless remote and grab a front door handle.	<b>High*<sup>1</sup>/Low</b>
	<b>Keyless Access Beep</b>	Sets the beeper sound or not when you grab either front door handle.	<b>ON*<sup>1</sup>/OFF</b>
	<b>Remote Start System ON/OFF*</b>	Turns the remote engine start feature on and off.	<b>ON*<sup>1</sup>/OFF</b>
<b>Lighting Setup</b>	<b>Interior Light Dimmer Duration</b>	Changes the length of time the interior lights stay on after you close the doors.	<b>60sec/30sec*<sup>1</sup>/15sec</b>
	<b>Headlight Auto OFF Timer</b>	Changes the length of time the exterior lights stay on after you close the driver's door.	<b>60sec/30sec/15sec*<sup>1</sup>/0sec</b>
	<b>Instrument Illumination Sensitivity</b>	Changes the sensitivity of the brightness of the instrument panel when the headlight switch is in the <b>AUTO</b> position.	<b>Max/High/Mid*<sup>1</sup>/Low/Min</b>
	<b>Headlight Integration With Wipers</b>	Changes the settings for the wiper operation when the headlights automatically come on while the headlight switch is in the <b>AUTO</b> position.	<b>ON*<sup>1</sup>/OFF</b>

\*1:Default Setting



Setup Group	Customizable Features	Description	Selectable Settings
Door Setup	<b>Auto Door Lock</b>	Changes the setting for when the doors automatically lock.	<b>With Vehicle Speed*<sup>1</sup>/Shift From P*<sup>2</sup>/OFF</b>
	<b>Auto Door Unlock</b>	Changes the setting for when the doors automatically unlock.	<b>Indian models</b> <b>Shift To P*<sup>2</sup>, *<sup>3</sup>/IGN OFF*<sup>4</sup>/OFF</b>
			<b>African models</b> <b>Driver Door With Shift To P*<sup>1</sup>/Driver Door With IGN OFF/All Doors With Shift To P/All Doors With IGN OFF/OFF</b>
	<b>Key And Remote Unlock Mode*</b>	Sets up either the driver's door or all doors to unlock on the first operation of the remote.	<b>Driver Door Only*<sup>1</sup>/All Doors</b>
<b>Walk Away Lock</b>	Changes the settings for the automatic locking the doors when you walk away from the vehicle while carrying the keyless access remote.	<b>ON/OFF*<sup>1</sup></b>	

\*1:Default Setting

\*2:Continuously variable transmission models

\*3:Default Setting for continuously variable transmission

\*4:Default Setting for manual transmission



Setup Group	Customizable Features	Description	Selectable Settings
Door Setup	<b>Keyless Lock Notification</b>	LOCK/UNLOCK- The exterior lights flash. LOCK (2nd push)- The beeper sounds.	<b>ON*<sup>1</sup>/OFF</b>
	<b>Security Relock Timer</b>	Changes the time it takes for the doors to relock and the security system to set after you unlock the vehicle without opening any door.	<b>90sec/60sec/30sec*<sup>1</sup></b>
	<b>Auto Folding Door Mirror*</b>	Changes how you can fold the door mirrors.	<b>Auto Fold With Keyless*<sup>1</sup>/ Manual Only</b>
<b>Default All</b>	—	Cancels customized changes you have made or restores them to their default setting.	<b>Cancel/OK</b>

\*1:Default Setting

### ■ Example of customization settings

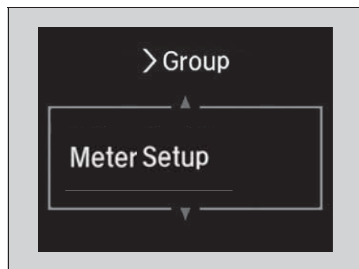
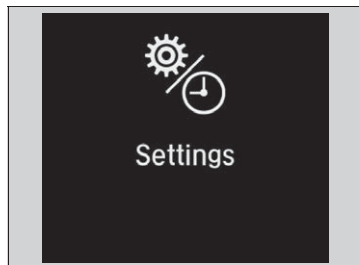
The steps for changing the “**Trip A**” **Reset Timing** setting to **When Fully Refueled** are shown below. The default setting for “**Trip A**” **Reset Timing** is **Manual Reset**.



1. Press the  (home) button and roll the left selector wheel to select , then press the left selector wheel.
2. Roll the left selector wheel until **Meter Setup** appears on the display.
3. Press the left selector wheel.
  - ▶ **Adjust Outside Temp. Display** appears first on the display.

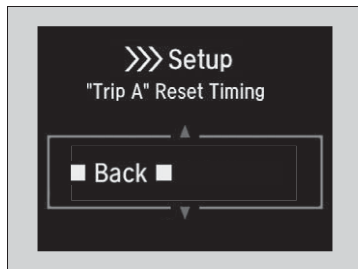
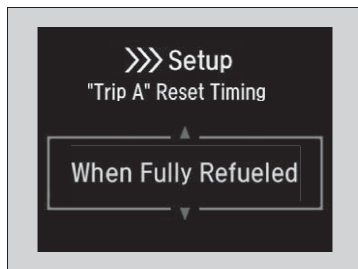
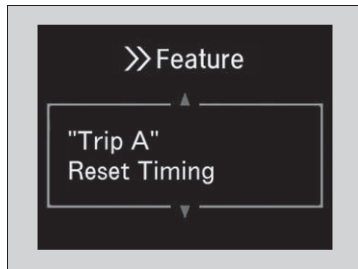

4. Roll the left selector wheel until **"Trip A" Reset Timing** appears on the display, then press the left selector wheel.
  - ▶ The display switches to the customization setup screen, where you can select **When Fully Refueled, When Ignition Is Turned OFF, Manual Reset, or Back**.
5. Roll the left selector wheel and select **When Fully Refueled**, then press the left selector wheel.
  - ▶ The display will return to the customization menu screen.
6. Roll the left selector wheel until **Back** appears on the display, then press the left selector wheel.
7. Repeat Step 6 until you return to the normal screen.

# Controls

This chapter explains how to operate the various controls necessary for driving.

<b>Clock</b> .....	124	<b>Security System Alarm</b> .....	149	<b>Adjusting the Steering Wheel</b> .....	171
<b>Locking and Unlocking the Doors</b>		<b>Windows</b> .....	151	<b>Mirrors</b>	
Key .....	126	<b>Sunroof*</b> .....	155	Interior Rearview Mirror .....	172
Locking/Unlocking the Doors from the Outside .....	128	<b>Operating the Switches Around the   Steering Wheel</b>		Power Door Mirrors .....	173
Locking/Unlocking the Doors from the Inside .....	135	ENGINE START/STOP Button.....	157	<b>Seats</b>	
Childproof Door Locks .....	138	Turn Signals .....	160	Front Seats .....	175
Auto Door Locking/Unlocking* .....	139	Light Switches.....	161	Armrest* .....	182
Customizing the Auto Door Locking/ Unlocking Setting* .....	140	Fog Lights* .....	163	<b>Interior Convenience Items</b> .....	183
<b>Opening and Closing the Boot</b> .....	146	Headlight Adjuster* .....	164	<b>Cooling System*</b>	
<b>Security System</b>		Daytime Running Lights .....	165	Using Vents and A/C.....	191
Immobilizer System .....	149	Wipers and Washers .....	166	<b>Climate Control System*</b>	
		Brightness Control .....	168	Using Automatic Climate Control ....	194
		Rear Demister Button.....	170	Automatic Climate Control Sensors...	197

\* Not available on all models

## Adjusting the Clock

You can adjust the time in the clock display with the power mode in ON.

### Adjusting the Time

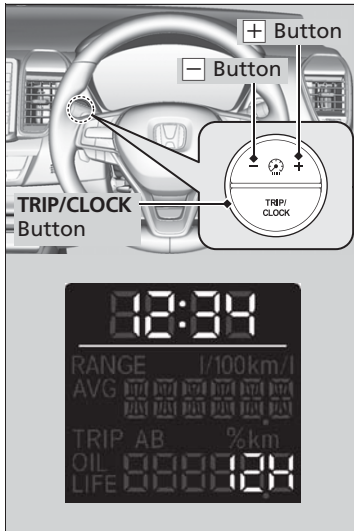

#### Models with information display

1. Press the **TRIP/CLOCK** button repeatedly until the displayed time begins flashing.
2. Press and hold the **TRIP/CLOCK** button to change the setting between 12h and 24h, or to turn off the clock.
3. Press the **+** or **-** button to adjust the minutes.  
As you increase or decrease the minutes, the hour moves forward or backward.
4. Press the **TRIP/CLOCK** button to complete clock adjustment.

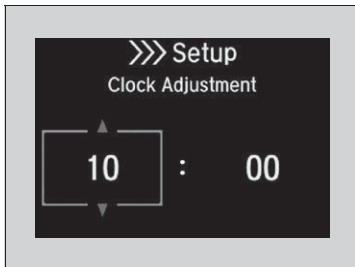
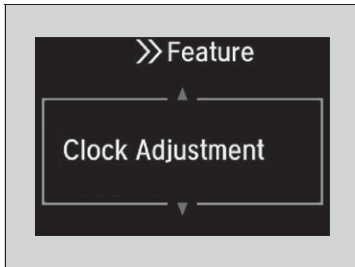
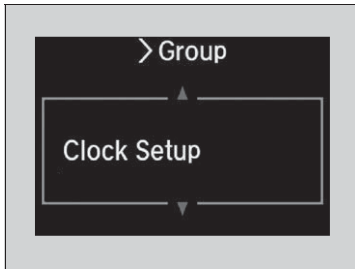

#### Models with driver information interface

1. Select the **Settings** screen.  
 ▶ **Settings** P. 116
2. Roll the left selector wheel to select **Clock Setup**, then push the left selector wheel.
3. Roll the left selector wheel until **Clock Adjustment** appears on the display.
4. Push the left selector wheel.
5. Roll the left selector wheel to change hour, then push the left selector wheel.
6. Roll the left selector wheel to change minute, then push the left selector wheel.
7. Press the  button to return to the normal screen.

## Key

This vehicle comes with the following keys:

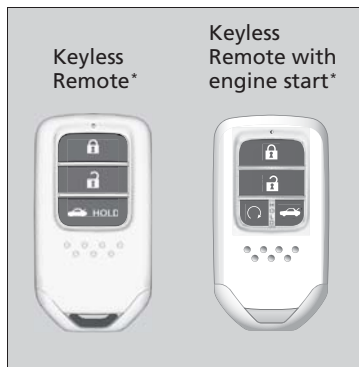

Use the key to start and stop the engine, and to lock and unlock all the doors and to open the boot.

### Built-in Key

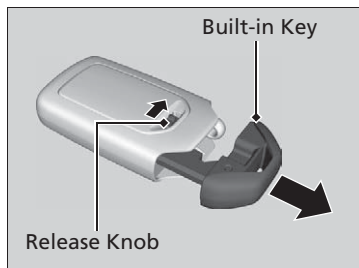

The built-in key can be used to lock/unlock the doors when the keyless remote battery becomes weak and the power door lock/unlock operation is disabled.

To remove the built-in key, slide the release knob and then pull out the key. To reinstall the built-in key, push the built-in key into the keyless remote until it clicks.

### Key

All the keys have an immobilizer system. The immobilizer system helps to protect against vehicle theft.

➔ **Immobilizer System** P. 149

Follow the advice below to prevent damage to the keys:

- Do not leave the keys in direct sunlight, or in locations with high temperature or high humidity.
- Do not drop the keys or set heavy objects on them.
- Keep the keys away from liquids, dust and sand.
- Do not take the keys apart except for replacing the battery.

If the circuits in the keys are damaged, the engine may not start, and the remote transmitter may not work.

If the keys do not work properly, have them inspected by a dealer.

### Models with remote engine start

You can remotely start the engine using the remote engine start.

➔ **Remote Engine Start\*** P. 209



## ■ Key Number Tag

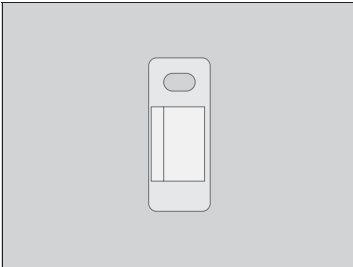

Contains a number that you will need if you purchase a replacement key.

## Low Keyless Remote Signal Strength

The vehicle transmits radio waves to locate the keyless remote when locking/unlocking the doors\*, opening the boot\*, or to start the engine.

In the following cases, locking/unlocking the doors or opening the boot or starting the engine may be inhibited or operation may be unstable:

- Strong radio waves are being transmitted by nearby equipment.
- You are carrying the keyless remote together with telecommunications equipment, laptop computers, mobile phones, or wireless devices.
- A metallic object is touching or covering the keyless remote.

\* Not available on all models

## ▣ Key Number Tag

Keep the key number tag separate from the key in a safe place outside of your vehicle. If you wish to purchase an additional key, contact a dealer.

If you lose your key and you cannot start the engine, contact a dealer.

## ▣ Low Keyless Remote Signal Strength

Communication between the keyless remote and the vehicle consumes the keyless remote's battery. Battery life is about two years, but this varies depending on regularity of use. The battery is consumed whenever the keyless remote is receiving strong radio waves. Avoid placing it near electrical appliances such as televisions and personal computers.

It is possible to reduce battery consumption by turning off radio wave reception. When you hold down the lock and unlock buttons at the same time for approximately three seconds, the LED will blink twice and radio wave reception will turn off. If you press any button on the keyless remote once, it will begin receiving radio waves again.

## Locking/Unlocking the Doors from the Outside

### ■ Using the Keyless Access System \*

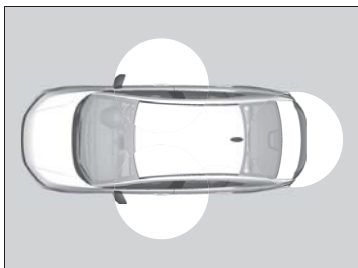

When you carry the keyless remote, you can lock/unlock the doors and open the boot.

You can lock/unlock the doors or open the boot within a radius of about 80 cm of the outside door handle.

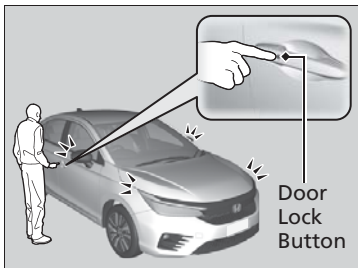

### ■ Locking the doors

Press the door lock button on the front door.

- ▶ Some exterior lights flash; the beeper sounds; all the doors and the boot lock; and the security system sets.

### ▶▶ Locking/Unlocking the Doors from the Outside

If the interior light switch is in the door activated position, the interior light comes on when you unlock the doors.

No doors opened: The light fades out after 30 seconds.

Doors relocked with the remote: The light goes off immediately.

▶▶ **Interior Lights** P. 183

### ▶▶ Using the Keyless Access System \*

If you do not open a door within 30 seconds of unlocking the vehicle, the doors will automatically relock.

You can lock or unlock doors using the keyless access system only when the power mode is in VEHICLE OFF (LOCK).

- Do not leave the keyless remote in the vehicle when you get out. Carry it with you.
- Even if you are not carrying the keyless remote, you can lock/unlock the doors while someone else with the remote is within range.
- The door may be unlocked if the door handle is covered with water in heavy rain or in a carwash if the keyless remote is within range.
- If you grip a front door handle wearing gloves, the door sensor may be slow to respond or may not respond by unlocking the doors.

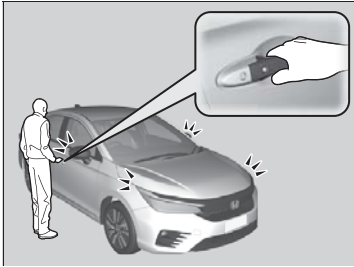

## ■ Unlocking the doors

### Except African models

Grab the front door handle.

- ▶ All the doors and the boot unlock.
- ▶ Some exterior lights flash twice and the beeper sounds twice.

### African models

Grab the driver's door handle:

- ▶ The driver's door unlocks.
- ▶ Some exterior lights flash twice and the beeper sounds twice.

Grab the front passenger's door handle:

- ▶ All doors unlock.
- ▶ Some exterior lights flash twice and the beeper sounds twice.

Press the boot release button:

- ▶ The boot unlocks and opens.
- ▶ Some exterior lights flash twice and the beeper sounds.

➤ **Using the Boot Release Button** P. 147

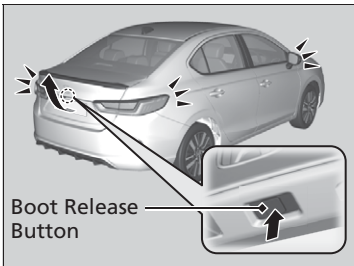

### ▶▶ Using the Keyless Access System\*

- After locking the door, you have up to 2 seconds during which you can pull the door handle to confirm whether the door is locked. If you need to unlock the door immediately after locking it, wait at least 2 seconds before gripping the handle, otherwise the door will not unlock.
- The door may not open if you pull it immediately after gripping the door handle. Grip the handle again and confirm that the door is unlocked before pulling the handle.
- Even within the 80 cm radius, you may not be able to lock/unlock the doors with the keyless remote if it is above or below the outside handle.
- The keyless remote may not operate if it is too close to the door and door glass.

\* Not available on all models

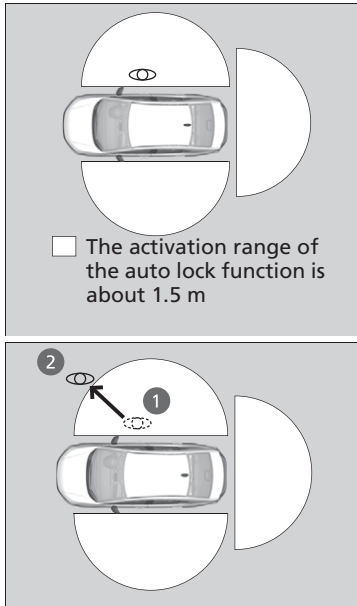

### ■ Locking the doors and boot (Walk away auto lock\*)

When you walk away from the vehicle while carrying the keyless remote, the doors will automatically lock.

The auto lock function activates when all doors are closed, and the keyless remote is within about 1.5 m radius of the outside door handle.

Exit vehicle while carrying keyless remote and close door(s).

1. While within about 1.5 m radius of the vehicle.
  - ▶ The beeper sounds; the auto lock function will be activated.
2. Carry the keyless remote beyond about 1.5 m from the vehicle and remain outside this range for 2 or more seconds.
  - ▶ Some exterior lights flash; the beeper sounds; all doors will then lock.

### ▶ Locking the doors and boot (Walk away auto lock\*)

The auto lock function is set to OFF as the factory default setting. The auto lock function can be set to ON using the driver information interface.

If you set the auto lock function to ON using the driver information interface, only the remote transmitter that was used to unlock the driver's door prior to the setting change can activate auto lock.

▶ **Settings** P. 116

After the auto lock function has been activated, when you stay within the locking/unlocking operation range, the indicator on the keyless remote will continue to flash until the doors are locked.

When you stay beside the vehicle within the operation range, the doors will automatically lock approximately 30 seconds after the auto lock function activating beeper sounds.

When you open a door after the auto lock function activating beeper sounds, the auto lock function will be cancelled.

Under the following circumstances, the auto lock function will not activate:

- The keyless remote is inside the vehicle.
  - ▶ The beeper will not sound.
- The keyless remote is taken out of its operational range before all the doors and tailgate are closed.
  - ▶ The beeper will sound.

To temporarily deactivate the function:

1. Set the power mode to OFF.
2. Open the driver's door.
3. Using the master door lock switch, operate the lock as follows:  
Lock→Unlock→Lock→Unlock.  
▶ The beeper sounds and the function is deactivated.

To restore the function (any step below):

- Set the power mode to ON.
- Lock the vehicle without using the auto lock function.
- With the keyless remote on you, move out of the auto lock function operation range.
- Open any door.

#### ⌘ Locking the doors and boot (Walk away auto lock\*)

The auto lock function does not operate when any of the following conditions are met.

- The keyless remote is inside the vehicle.
- A door or the bonnet is not closed.
- The power mode is set to any mode other than OFF.
- The keyless remote is not located within a radius of about 1.5 m from the vehicle when you get out of the vehicle and close the doors.

#### **Auto lock function operation stop beeper**

After the auto lock function has been activated, the auto lock operation stop beeper sounds for approximately two seconds in the following cases.

- The keyless remote is put inside the vehicle through a window.
- You are located too close to the vehicle.
- The keyless remote is put inside the boot.

If the warning beeper sounds, check that you are carrying the keyless remote. Then, open/close a door and confirm the auto lock activation beeper sounds once.

## ■ Using the Remote Transmitter

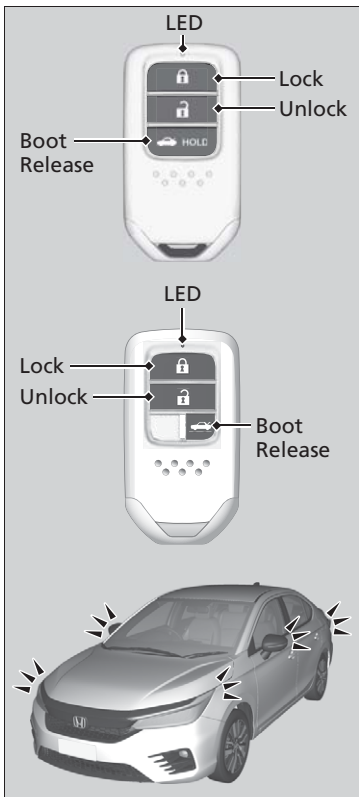

### ■ Locking the doors

Press the lock button.

#### Once:

- ▶ Some exterior lights flash, all the doors lock, and the security system sets.

#### Twice (within five seconds after the first push):

- ▶ The beeper sounds and verifies the security system is set.

### ■ Unlocking the doors

#### Except African models

Press the unlock button.

- ▶ Some exterior lights flash twice, and all doors unlock.

#### African models

Press the unlock button.

#### Once:

- ▶ Some exterior lights flash twice, and the driver's door unlocks.

#### Twice:

- ▶ The remaining doors unlock.

## ▶▶ Using the Remote Transmitter

If you do not open a door within 30 seconds of unlocking the vehicle with the remote transmitter, the doors will automatically relock.

You can lock or unlock doors using the remote transmitter only when the power mode is in VEHICLE OFF (LOCK).

The remote transmitter uses low-power signals, so the operating range may vary depending on the surroundings.

The remote will not lock the vehicle when a door is open.

If the distance at which the remote transmitter works varies, the battery is probably low. Replace the button battery as soon as possible when this occurs. If the LED does not come on when you press a button, the battery is dead.

#### ▶▶ Replacing the Button Battery P. 306

## ■ Locking/Unlocking the Doors Using a Key

If the lock or unlock button of the keyless remote does not work, use the key instead.

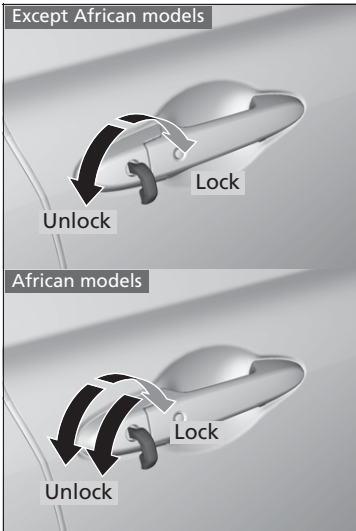

Fully insert the key and turn it.

## » Locking/Unlocking the Doors Using a Key

### Except African models

When you lock/unlock the driver's door with the key, all the other doors lock/unlock at the same time.

### African models

When you lock the driver's door with the key, all the other doors lock at the same time.

When unlocking, the driver's door unlocks first.

Turning the key a second time within a few seconds does not unlock the remaining doors.

### Except Latin American models

If you unlock a door with the built-in key while the security system is activated, the alarm will go off.

You can customize the door unlock mode setting.

➔ **Settings** P. 116

## ■ Locking a Door Without Using a Key

If you do not have the key on you, or if for some reason you cannot lock a door using the key, you can lock the door without it.

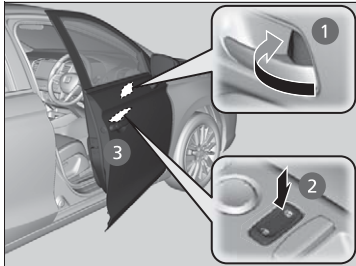

### ■ Locking the driver's door

Push the lock tab forward **1** or push the master door lock switch in the lock direction **2**, then pull and hold the outside door handle **3**. Close the door, then release the handle.

### ■ Locking the passenger's doors

Push the lock tab forward and close the door.

### ■ Lockout prevention system

The doors cannot be locked when the keyless remote is inside the vehicle.

## ▶ Locking a Door Without Using a Key

When you lock the driver's door, all the other doors lock at the same time.  
Before locking a door, make sure that the key is not inside the vehicle.



## Locking/Unlocking the Doors from the Inside

### ■ Using the Lock Tab

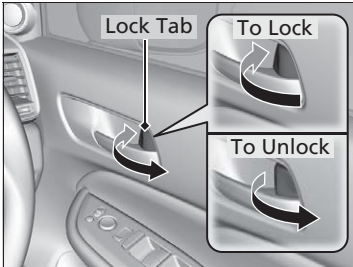

#### ■ Locking a door

Push the lock tab forward.

#### ■ Unlocking a door

Pull the lock tab rearward.

### » Using the Lock Tab

#### ■ Except African models

When you lock/unlock the door using the lock tab on the driver's door, all the other doors lock/unlock at the same time.

#### ■ African models

When you lock the door using the lock tab on the driver's door, all the other doors lock at the same time.

When you unlock the door using the lock tab on the driver's door, only the driver's door will unlock.

## ■ Unlocking Using the Front Door Inner Handle

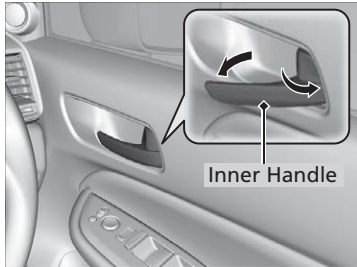

### Except African and Latin American models

Pull the driver's door inner handle.

- ▶ The door unlocks and opens in one motion.

### African and Latin American models

Pull the front door inner handle.

- ▶ The door unlocks and opens in one motion.

## » Unlocking Using the Front Door Inner Handle

### Except African and Latin American models

The driver's door inner handle are designed to allow the driver to open the door in one motion. However, this feature requires that the driver never pull the door inner handle while the vehicle is in motion.

### African and Latin American models

The front door inner handles are designed to allow front seat occupants to open the door in one motion. However, this feature requires that front seat occupants never pull a front door inner handle while the vehicle is in motion.

Children should always ride in a rear seat where childproof door locks are provided.

➤ **Childproof Door Locks** P. 138

## ■ Using the Master Door Lock Switch

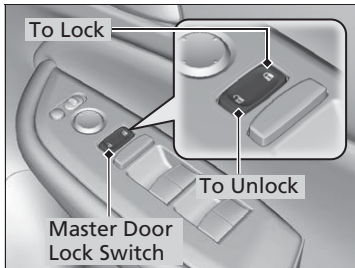

Press the master door lock switch in as shown to lock or unlock all doors.

## ▣ Using the Master Door Lock Switch

When you lock/unlock the driver's door using the master door lock switch, all the other doors lock/unlock at the same time.

## Childproof Door Locks

The childproof door locks prevent the rear doors from being opened from the inside regardless of the position of the lock tab.

### ■ Setting the Childproof Door Locks

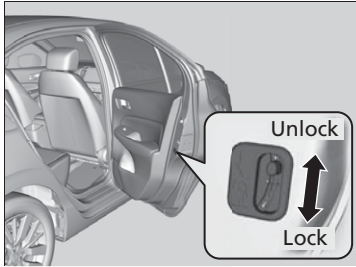

Slide the lever in the rear door to the lock position, and close the door.

### ■ When opening the door

Open the door using the outside door handle.

### ☒ Childproof Door Locks

To open the door from the inside when the childproof door lock is on, put the lock tab in the unlock position, lower the rear window, put your hand out of the window, and pull the outside door handle.

## Auto Door Locking/Unlocking\*

Your vehicle locks all doors or unlocks all doors\*/the driver's door\* automatically when a certain condition is met.

### ■ Auto Door Locking

#### ■ Drive lock mode

All doors lock when the vehicle's speed reaches about 15 km/h.

### ■ Auto Door Unlocking

#### Continuously variable transmission models

#### ■ Park unlock mode

All doors unlock when the transmission is put into **P** with the brake pedal depressed.

#### Manual transmission models

#### ■ Power mode unlock mode

#### Except African models

All door unlock when the power mode is out of ON.

#### African models

The driver's door unlocks when the power mode is out of ON.

### ▶▶ Auto Door Locking/Unlocking\*

#### Models without driver information interface

You can turn off or change to another auto door locking/unlocking setting using the master door lock switch.

#### ▶ Customizing the Auto Door Locking/Unlocking Setting\* P. 140

#### Models with driver information interface

You can turn off or change to another auto door locking/unlocking setting using the driver information interface.

#### ▶ Settings P. 116

\* Not available on all models

## Customizing the Auto Door Locking/Unlocking Setting \*

You can customize the auto door locking/unlocking setting to your liking using the master door lock switch.

### List of the Auto Door Locking/Unlocking Customizable Options

#### Auto door locking

Mode	Description
Drive Lock Mode <sup>*1</sup>	All doors lock when the vehicle's speed reach about 15 km/h.
Park Lock Mode <sup>*2</sup>	All doors lock when the brake pedal is depressed and the transmission is taken out of [P].
Off	The auto door locking is deactivated all the time.

## ■ Auto door unlocking

Continuously variable transmission models

Mode		Description
<b>Park Unlock Mode</b> <sup>*1</sup>	<b>To unlock driver's door</b> <sup>*3, *4</sup>	The driver's door unlocks when the transmission is put into <b>P</b> with the brake pedal depressed.
	<b>To unlock all doors</b>	All doors unlock when the transmission is put into <b>P</b> with the brake pedal depressed.
<b>Power Mode Unlock Mode</b>	<b>To unlock driver's door</b> <sup>*3, *4</sup>	The driver's door unlocks when the power mode is out of ON.
	<b>To unlock all doors</b>	All doors unlock when the power mode is out of ON.
<b>Off</b>		The auto door unlocking is deactivated all the time.

\*1:Default setting

\*2:Continuously variable transmission models only

\*3:African models only

\*4:Default setting for African models

Manual transmission models

Mode		Description
<b>Power Mode Unlock Mode</b> <sup>*1</sup>	<b>To unlock driver's door</b> <sup>*2, *3</sup>	The driver's door unlocks when the power mode is out of ON.
	<b>To unlock all doors</b>	All doors unlock when the power mode is out of ON.
<b>Off</b>		The auto door unlocking is deactivated all the time.

\*1:Default setting

\*2:African models only

\*3:Default setting for African models



## ■ Customizing Flow for Auto Door Locking Options

Steps	Drive Lock Mode	Park Lock Mode* <sup>1</sup>	Off
1	Apply the parking brake. Make sure the shift lever is in <b>P</b> .		
2	Set the power mode to ON.		
3	The driver's door must be closed at this stage.		Open the driver's door.
4	Move the shift lever out of <b>P</b> with the brake pedal depressed.		–
5	Press and hold the right side of the master door lock switch on the driver's door. You will hear a click more than five seconds elapsed. Release the switch.		
			
6	Move the shift lever to <b>P</b> .		–
7	Push the <b>ENGINE START/STOP</b> button once without depressing the brake pedal within 20 seconds. ▶ Customization is completed.		

\*1:Continuously variable transmission models only

## ■ Customizing Flow for Auto Door Unlocking Options

Steps	Power Mode Unlock Mode		Park Unlock Mode*2		Off
	To unlock driver's door*1	To unlock all doors	To unlock driver's door*1	To unlock all doors	
1	Apply the parking brake. Make sure the shift lever is in <b>P</b> *2.				
2	Set the power mode to ON.				
3	The driver's door must be closed at this stage.				Open the driver's door.
4	The transmission is taken out of <b>P</b> with the brake pedal depressed*2.		-		
5	Press and hold the left side of the master door lock switch on the driver's door. You will hear a click more than five seconds elapsed.				



\*1:African models only

\*2:Continuously variable transmission models only

Steps	Power Mode Unlock Mode		Park Unlock Mode <sup>*2</sup>		Off
	To unlock driver's door <sup>*1</sup>	To unlock all doors	To unlock driver's door <sup>*1</sup>	To unlock all doors	
6	Release the switch.	<p><b>Except African models</b> Release the switch.</p> <p><b>African models</b> Keep pressing the switch for another five seconds to hear one more click.</p>	Release the switch.	<p><b>Except African models</b> Release the switch.</p> <p><b>African models</b> Keep pressing the switch for another five seconds to hear one more click.</p>	Release the switch.
7	Move the shift lever to <b>P</b> <sup>*2</sup> .		—		
8	Push the <b>ENGINE START/STOP</b> button once without depressing the brake pedal within 20 seconds. ▶ Customization is completed.				

\*1:African models only

\*2:Continuously variable transmission models only

## Precautions for Opening/Closing the Boot

### ■ Opening the boot

Open the boot all the way.

- ▶ If it is not fully opened, the boot lid may begin to close under its own weight.

### ■ Closing the boot

Keep the boot lid closed while driving to:

- ▶ Avoid possible damage.
- ▶ Prevent exhaust gas from leaking into the vehicle.

☒ **Exhaust Gas Hazard** P. 84

## Using the Boot Opener

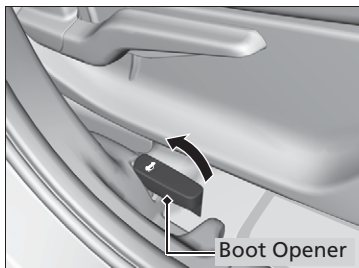

Pulling the boot opener on the outside of the driver's seat unlocks and opens the boot.

## Using the Boot Release Button

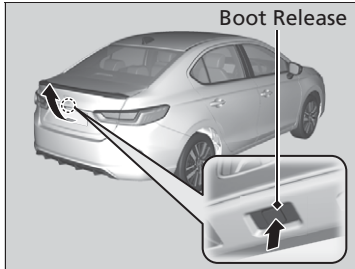

Push up the release button on the boot lid after the doors are unlocked.

Even if the boot is locked, you can open the boot if you carry the keyless remote.

- ▶ Some exterior lights flash twice and the beeper sounds once.

### Using the Boot Release Button

- If you forget the remote inside, the beeper will sound and the boot will not close.
- A person who is not carrying the keyless remote can unlock the boot if a person who is carrying it is within range.
- If the beeper sounds after you close the boot, move the keyless remote away from the boot and close again.
- The keyless remote may not operate if it is too close to the boot.

## Using the Remote Transmitter

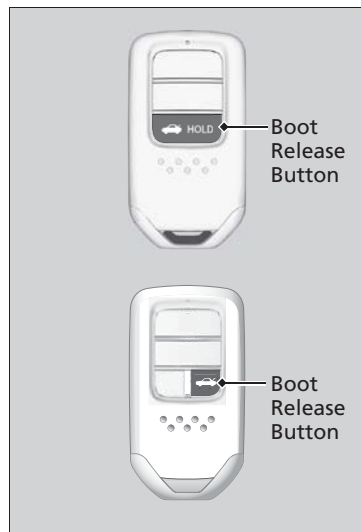

Press the boot release button for approximately one second to unlock and open the boot.

### ▶▶ Using the Remote Transmitter

If the driver's door is locked, the boot will automatically lock when you close it. Otherwise, you will have to lock it manually.

## Immobilizer System

This system prevents a key that has not been preregistered from starting the engine.

Pay attention to the following when pressing the **ENGINE START/STOP** button:

- Do not allow objects that emit strong radio waves near the **ENGINE START/STOP** button.
- Make sure the key is not covered by or touching a metal object.
- Do not bring a key from another vehicle's immobilizer system near the **ENGINE START/STOP** button.

Do not put the key near magnetic items. Electronic device, such as televisions and audio systems emit strong magnetic fields. Note that even a key chain can become magnetic.

## Security System Alarm

The security system alarm activates when the boot, bonnet or doors are forcibly opened. The alarm does not activate if the boot or doors are opened with the key\*, remote transmitter or keyless access system\*.

### ■ When the security system alarm activates

The horn sounds intermittently, and some exterior lights flash.

\* Not available on all models

### Immobilizer System

#### NOTICE

Leaving the key in the vehicle can result in theft or accidental movement of the vehicle. Always take the key with you whenever you leave the vehicle unattended.

Do not alter the system or add other devices to it. Doing so may damage the system and make your vehicle inoperable.

If the system repeatedly does not recognise the coding of your key, contact a dealer. If you have lost your key and cannot start your vehicle, contact a dealer.

### Security System Alarm

Do not alter the system or add other devices to it. Doing so may damage the system and make your vehicle inoperable.

The security system alarm will continue for approximately 5 minutes before the security system deactivates.

The system will go through ten 30-second cycles, during which the horn will sound and an emergency indicator will flash.

Depending on circumstances, the security system may continue operating for more than 5 minutes.

### ■ To deactivate the security system alarm

Unlock the vehicle using the key\*, remote transmitter or keyless access system\*, or set the power mode to ON. The system, along with the horn and flashing lights, is deactivated.

### ■ Setting the security system alarm

The security system alarm automatically sets when the following conditions have been met:

- The power mode is set to VEHICLE OFF (LOCK).
- The bonnet is closed.
- All doors are locked from outside with the key, remote transmitter, or keyless access system\*.

### ■ When the security system alarm sets

The security system alarm indicator in the instrument panel blinks and the blinking interval changes after about 15 seconds.

### ■ To cancel the security system alarm

The security system alarm is cancelled when the vehicle is unlocked using the key\*, remote transmitter or keyless access system\*, or when the power mode is set to ON. The security system alarm indicator goes off at the same time.

#### » Security System Alarm

Do not set the security system alarm when someone is in the vehicle or a window is open. The system can accidentally activate when:

- Unlocking the door with the lock tab.
- Opening the boot with the boot opener.
- Opening the bonnet with the bonnet release.

If the battery goes dead after you have set the security system alarm, the security alarm may go off once the battery is recharged or replaced.

If this occurs, deactivate the security system alarm by unlocking a door using the key\*, remote transmitter or keyless access system\*.

#### Except Latin American models

If you unlock a door with the built-in key while the security system is activated, the alarm will go off.



## Opening/Closing the Power Windows

The power windows can be opened and closed when the power mode is in ON, using the switches on the doors.

The driver's side switches can be used to open and close all of the windows. The power window lock button on the driver side must be switched off (indicator off) to open and close the windows from anywhere other than the driver's seat.

When the power window lock button is pushed in, the indicator comes on and you can only operate the driver's window. Turn the power window lock button on if a child is in the vehicle.

### Opening/Closing the Power Windows

#### **WARNING**

**Closing a power window on someone's hands or fingers can cause serious injury.**

**Make sure your passengers are away from the windows before closing them.**

**WARNING:** Always take the ignition key with you whenever you leave the vehicle alone or with other occupants.

**Models with power window auto-open/close function except driver's window**

The power windows can be operated for up to 10 minutes after you set the power mode to VEHICLE OFF. Closing driver's door cancels this function.

## ■ Opening/Closing the Windows with Auto-Open/Close Function

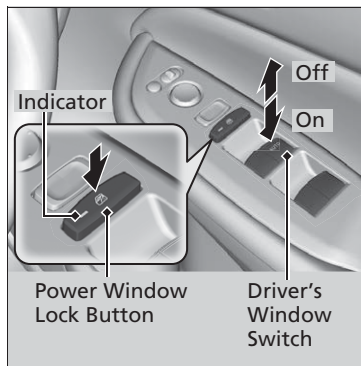

### ■ Manual operation

**To open:** Push the switch down lightly, and hold it until the desired position is reached.

**To close:** Pull the switch up lightly, and hold it until the desired position is reached.

### ■ Automatic operation

**To open:** Push the switch down firmly.

**To close:** Pull the switch up firmly.

The window opens or closes completely. To stop the window at any time, push or pull the switch briefly.

## ▣ Opening/Closing the Power Windows

### Auto Reverse

If a power window senses resistance when closing automatically, it will stop closing and reverse direction.

The driver's window auto reverse function is disabled when you continuously pull up the switch.

The auto reverse function stops sensing when the window is almost closed to ensure that it fully closes.

## ■ Opening/Closing Windows without Auto-Open/Close Function

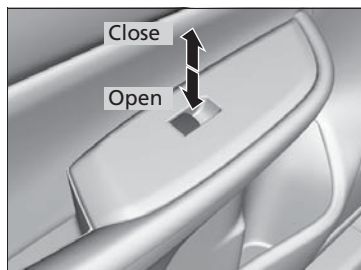

**To open:** Push the switch down.

**To close:** Pull the switch up.

Release the switch when the window reaches the desired position.

## ■ Opening/Closing the Windows with the Remote \*

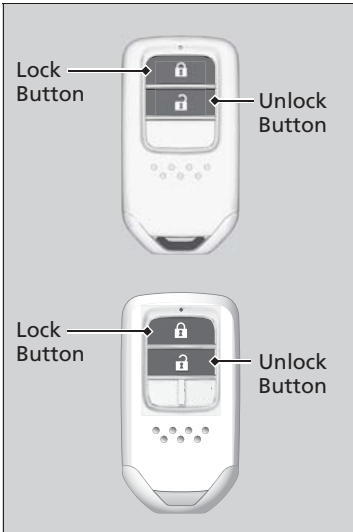

**To open:** Press the unlock button, and then within 10 seconds, press it again and hold it.

**To close:** Press the lock button, and then within 10 seconds, press it again and hold it.

If the windows stop midway, repeat the procedure.

## ☒ Opening/Closing the Windows with the Remote \*

If you open/close the windows with the remote, the sunroof will open/close automatically along with them.

\* Not available on all models

### ■ Closing the Windows with the Key\*



**To close:** Lock the driver's door with the key. Within 10 seconds of returning the key to the central position, turn the key in the lock direction and hold it there.

Release the key to stop the windows at the desired position. If you want further adjustment, repeat the same operation.

### ▶▶ Closing the Windows with the Key\*

If you close the windows with the key, the sunroof will close automatically along with them.

## Opening/Closing the Sunroof

You can only operate the sunroof when the power mode is in ON. Use the switch in the front of the ceiling to open and close the sunroof.

### Using the Sunroof Switch

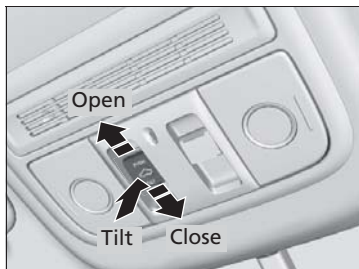

#### Automatic operation

**To open:** Pull the switch back firmly.

**To close:** Push the switch forward firmly.

The sunroof will automatically open or close all the way. To stop the sunroof midway, touch the switch briefly.

#### Manual operation

**To open:** Pull the switch back lightly, and hold it until the desired position is reached.

**To close:** Push the switch forward lightly, and hold it until the desired position is reached.

#### Tilting the sunroof up

**To tilt:** Push on the centre of the sunroof switch.

**To close:** Push the switch forward firmly, then release.

☞ Sunroof\*

### ⚠ WARNING

Opening or closing the sunroof on someone's hands or fingers can cause serious injury.

Make sure all hands and fingers are clear of the sunroof before opening or closing it.

**WARNING:** Always take the ignition key with you whenever you leave the vehicle alone or with other occupants.

#### NOTICE

Opening the sunroof in below freezing temperature or when it is covered with snow or ice can damage the sunroof panel or motor.

Models with power window auto-open/close function except driver's window

The sunroof can be operated for up to 10 minutes after you set the power mode to VEHICLE OFF (LOCK). Closing driver's door cancels this function.

When resistance is detected, the auto reverse function causes the sunroof to change directions, then stop. Auto reverse stops sensing when the sunroof is almost closed to ensure that it fully closes. Make sure that all objects, including fingers, are clear of the sunroof.

☞ Sunroof\*

You can use the remote transmitter or the key to operate the sunroof\*.

- ☞ **Opening/Closing the Windows with the Remote\*** P. 153
- ☞ **Closing the Windows with the Key\*** P. 154

## ENGINE START/STOP Button

### Changing the Power Mode

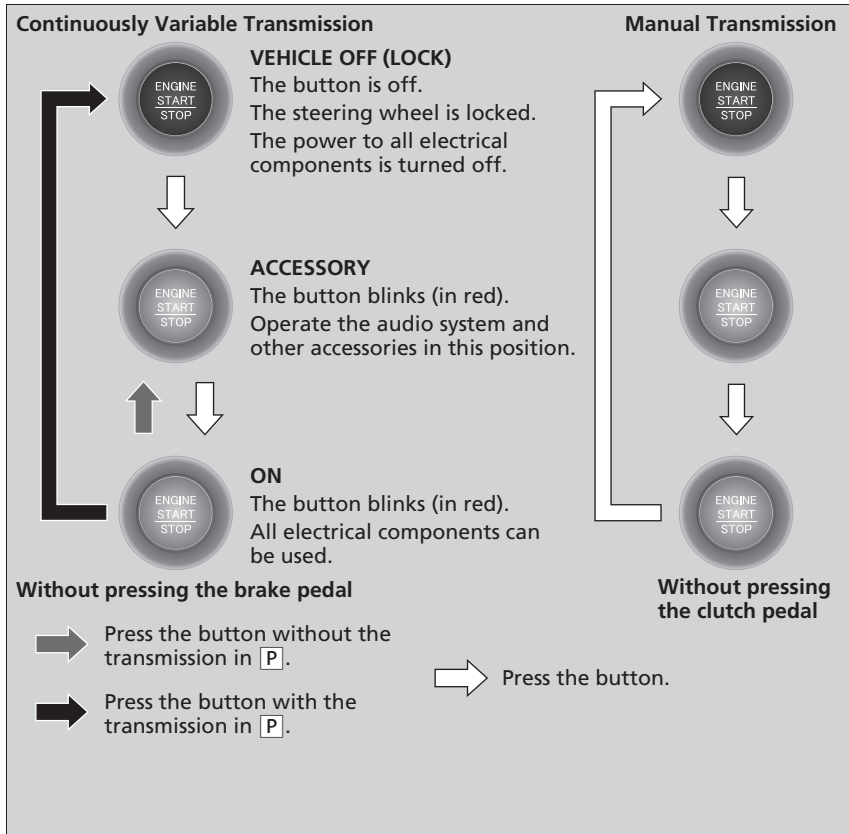

### ENGINE START/STOP Button

#### ENGINE START/STOP Button Operating Range

You can start the engine when the keyless remote is inside the vehicle.

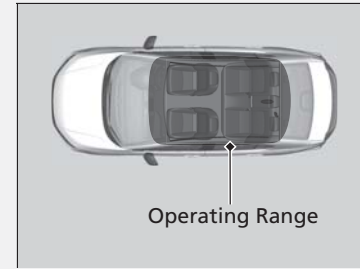

If the battery of the keyless remote is getting low, the engine may not start when you push the **ENGINE START/STOP** button. If the engine does not start, refer to the following link.

➔ **If the Keyless Remote Battery is Weak**  
P. 331

The engine may also run if the keyless remote is close to the door or window, even if it is outside the vehicle.

ON mode:

The **ENGINE START/STOP** button is on (in red), if the engine is running.

Continued

## ■ Automatic Power Off

If you leave the vehicle for 30 to 60 minutes with the transmission in **P** (continuously variable transmission) and the power mode in ACCESSORY, the vehicle automatically goes into the mode similar to VEHICLE OFF (LOCK) to avoid draining the battery.

When in this mode:

The steering wheel does not lock. You cannot lock or unlock doors with the remote transmitter or the keyless access system.

Press the **ENGINE START/STOP** button twice to switch the mode to VEHICLE OFF (LOCK).

## ■ Power Mode Reminder

If you open the driver's door when the power mode is set to ACCESSORY, a warning beep sounds.

## ▶▶ ENGINE START/STOP Button

If the power mode does not change from VEHICLE OFF to ACCESSORY, press the **ENGINE START/STOP** button while moving the steering wheel left and right. The steering wheel will unlock, allowing the mode to change.

Do not leave the power mode in ACCESSORY or ON when you get out.



## Keyless Remote Reminder

### Models with information display

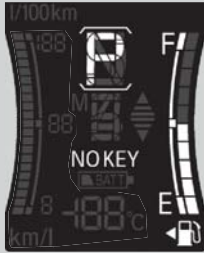

### Models with driver information interface

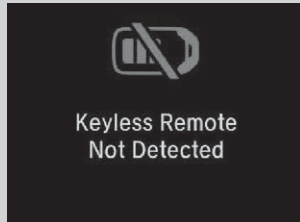

When the power mode is set to any mode other than OFF and you remove the keyless remote from the vehicle and shut the door, an alarm will sound. If the alarm continues to sound, place the keyless remote in another location.

#### ■ When the power mode is in ACCESSORY

The alarm will sound from outside the vehicle.

#### ■ When the power mode is in ON

An alarm will sound both inside and outside the vehicle. In addition, a warning indicator will appear on the instrument panel.

### Keyless Remote Reminder

When the keyless remote is within the system's operational range, and the driver's door is closed, the warning function cancels.

If the keyless remote is taken out of the vehicle after the engine has been started, you can no longer change the **ENGINE START/STOP** button mode or restart the engine. Always make sure if the remote is in your vehicle when you operate the **ENGINE START/STOP** button.

Removing the keyless remote from the vehicle through a window does not activate the warning buzzer.

Do not put the keyless remote on the dashboard or in the glove box. It may cause the warning buzzer to go off. Under some other conditions that can prevent the vehicle from locating the remote, the warning buzzer may also go off even if the remote is within the system's operational range.

## Turn Signals

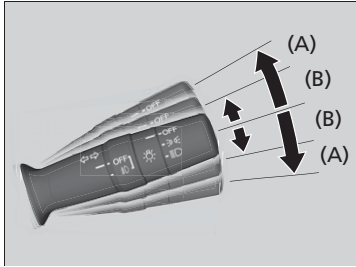

The turn signals can be used when the power mode is in ON.

### ■ (A): Turn signal

Push the lever up or down based on the direction you want to turn, and the turn signal will blink.

### ■ (B): One-touch turn signal

When you lightly push the lever up or down and release it, the turn signal will blink 3 times.

- ▶ If you lightly push the lever in the opposite direction while it is blinking, the blinking will stop.

### ▶▶ Turn Signals

The turn signal indicator on the instrument panel will blink when the external turn signal blinks.

▶▶ Indicators P. 88

## Light Switches

### Manual Operation

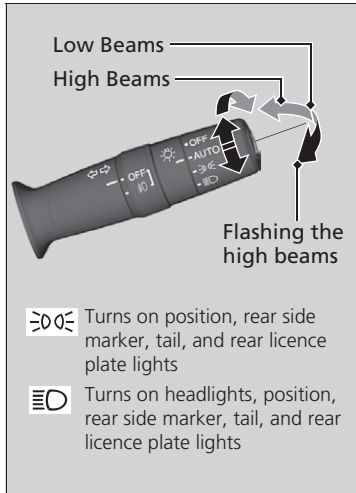

Rotating the light switch turns the lights on and off, regardless of the position of the power mode setting.

#### ■ High beams

Push the lever forward until you hear a click.

#### ■ Low beams

When in high beams, pull the lever back to return to low beams.

#### ■ Flashing the high beams

Pull the lever back, and release it.

#### ■ Lights off\*

Turn the lever to **OFF** either when:

- The transmission is in **P** (Continuously Variable Transmission models).
- The parking brake is applied.

To turn the lights on again, turn the lever to OFF to cancel the lights off mode. Even if you do not cancel the lights off mode, the lights come on automatically when:

- The transmission is taken out of **P** (Continuously Variable Transmission models) and the parking brake is released.
- The vehicle starts to move.

### Light Switches

If you leave the power mode in VEHICLE OFF (LOCK) while the lights are on, a chime sounds when the driver's door is opened.

When the lights are on, the lights on indicator in the instrument panel will be on.

➤ **Indicators** P. 88

Do not leave the lights on when the engine is off because it will cause the battery to discharge.

#### Models without headlight adjuster

If you sense that the level of the headlights is abnormal, have the vehicle inspected by a dealer.

\* Not available on all models

### ■ Automatic Operation (automatic lighting control)\*

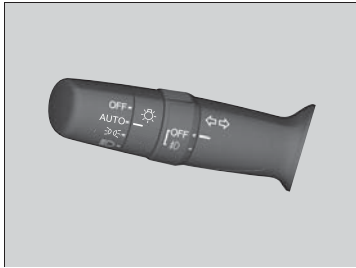

Automatic lighting control can be used when the power mode is in ON.

When the light switch is in **AUTO**, the headlights and other exterior lights will switch on and off automatically depending on the ambient brightness.

The headlights come on when you unlock a door in dark areas with the headlight switch in **AUTO**.

- ▶ Once you lock the door, the headlights will go off.

### ■ Automatic Lighting Off Feature

The headlights, all other exterior lights, and the instrument panel lights turn off 15 seconds after you set the power mode to VEHICLE OFF (LOCK), take the remote with you, and close the driver's door.

If you turn the power mode to VEHICLE OFF (LOCK) with the headlight switch on, but do not open the door, the lights turn off after 10 minutes (3 minutes, if the switch is in the **AUTO** position).

The lights turn on again when you unlock or open the driver's door. If you unlock the door, but do not open it within 15 seconds, the lights go off. If you open the driver's door, you will hear a lights on reminder chime.

### ▶▶ Automatic Operation (automatic lighting control)\*

We recommend that you turn on the lights manually when driving at night, in a dense fog, or in dark areas such as long tunnels or parking facilities.

The light sensor is in the location shown below. Do not cover this light sensor with anything; otherwise, the automatic lighting system may not work properly.

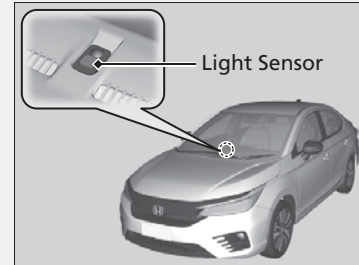

### ▶▶ Automatic Lighting Off Feature

You can change the headlight auto off timer setting.

▶ **Settings** P. 116

## Fog Lights\*



Can be used when the position lights or the headlights are on.

\* Not available on all models

## Headlight Adjuster\*

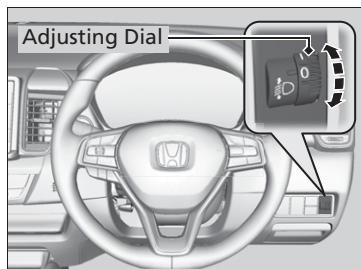

You can adjust the vertical angle of the low beam headlights when the power mode is in ON.

Turn the adjustment dial to select an appropriate angle for the headlights.

The larger dial number indicates the lower angle.

### ■ To select the adjustment dial position

Refer to the below table for the appropriate dial position for your vehicle's riding and loading conditions.

Condition	Dial position
A driver	0
A driver and a front passenger	0
Five persons in the front and rear seats	1
Five persons in the front and rear seats and luggage in the boot, within the limits of maximum permissible axle weight and maximum permissible vehicle weight	2
A driver and luggage in the boot, within the limits of maximum permissible axle weight and maximum permissible vehicle weight	3

## Daytime Running Lights

---

The position/daytime running lights come on when the following conditions have been met:

### Models without automatic lighting control

- The power mode is in ON.
- The headlight switch is off.

Setting the power mode to VEHICLE OFF (LOCK) will turn off the daytime running lights.

### Models with automatic lighting control

- The power mode is in ON.
- The headlight switch is in **AUTO**.

Setting the power mode to VEHICLE OFF (LOCK) will turn off the daytime running lights.

The daytime running lights are off once the headlight switch is turned on, or when the head light switch is in **AUTO** and it is getting darker outside.

## Wipers and Washers

### ■ Windscreen Wipers/Washers



The windscreen wipers and washers can be used when the power mode is in ON.

#### ■ MIST

The wipers run at high speed until you release the lever.

#### ■ Wiper switch (OFF, INT, LO, HI)

Move the lever up or down to change the wiper settings.

#### ■ Adjusting wiper operation\*

Turn the adjustment ring to adjust the wiper operation.

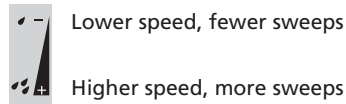

#### ■ Washer

Sprays while you pull the lever towards you. When you release the lever for more than one second, the spray stops, the wipers sweep two or three more times to clear the windscreen, then stop.

### » Wipers and Washers

#### NOTICE

Do not use the wipers when the windscreen is dry. The windscreen will get scratched, or the rubber blades will get damaged.

#### NOTICE

Turn the washers off if no washer fluid comes out. The pump may get damaged.

The wiper motor may stop motor operation temporarily to prevent an overload. Wiper operation will return to normal within a few minutes, once the circuit has returned to normal.

#### Models with intermittent time adjustment ring

If the vehicle speeds up while the wipers are operating intermittently, the length of the wipe interval shortens.

When the vehicle speeds up, the wiper operation's shortest delay setting (👉) and the LO setting become the same.



» Wipers and Washers

**NOTICE**

In cold weather, the blades may freeze to the windscreen.

Operating the wipers in this condition may damage the wipers. Use the demister to warm the windscreen, then turn the wipers on.

If the wipers stop operating due to any obstacle such as the build-up of snow, park the vehicle in a safe place.

Rotate the wiper switch to **OFF**, and set the power mode to ACCESSORY or VEHICLE OFF (LOCK), then remove the obstacle.

## Brightness Control

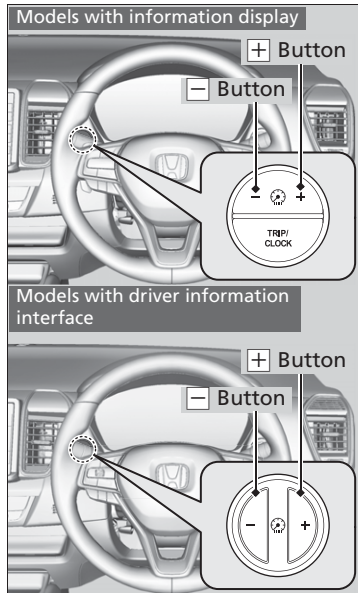

### Models with information display

When the brightness of the meter will be reduced, you can use the **+** or **-** button to adjust instrument panel brightness.

**Brighten:** Press the **+** button.

**Dim:** Press the **-** button.

### Models with driver information interface

When the power mode is in ON, you can use the **+** or **-** button to adjust instrument panel brightness.

**Brighten:** Press the **+** button.

**Dim:** Press the **-** button.

You will hear a beep when the brightness reaches minimum or maximum. Several seconds after you have adjusted the brightness, you will be returned to the previous screen.

### » Brightness Control

The brightness of the instrument panel will be reduced when the following conditions:

#### Models without automatic lighting control

- The power mode is in ON.
- The position lights are turned on.

#### Models with automatic lighting control

- The power mode is in ON.
- The light switch is in any position other than off and it is dark outside.

The brightness can be set differently for when the exterior lights are on, and when they are off.

Models with information display



Models with driver information interface



### ■ Brightness level indicator

The brightness level is shown on the display while you are adjusting it.

## Rear Demister Button

Models with cooling system

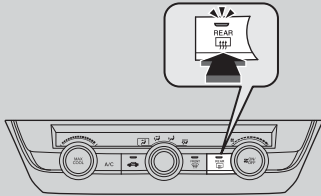

Models with climate control system

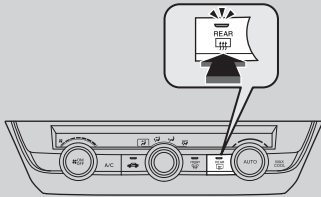

Press the rear demister button to demist the rear window when the power mode is in ON.

The rear demister automatically switches off after 10-30 minutes depending on the outside temperature.

However, if the outside temperature is 0°C or below, it does not automatically switch off.

### ⌘ Rear Demister Button

This system consumes a lot of power, so turn it off when the window has been demisted. Also, do not use the system for a long time while the engine is idling. This may weaken the battery, making it difficult to start the engine.

## Adjusting the Steering Wheel

The steering wheel height and distance from your body can be adjusted so that you can comfortably grip the steering wheel in an appropriate driving posture.

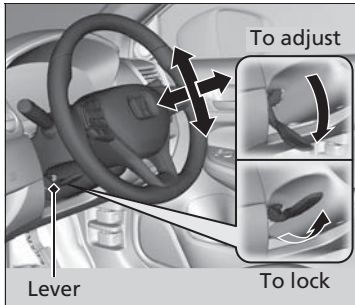

1. Push the steering wheel adjustment lever down.
  - ▶ The steering wheel adjustment lever is under the steering column.
2. Move the steering wheel up or down, and in or out.
  - ▶ Make sure you can see the instrument panel gauges and indicators.
3. Pull the steering wheel adjustment lever up to lock the steering wheel in position.
  - ▶ After adjusting the position, make sure you have securely locked the steering wheel in place by trying to move it up, down, in, and out.

### Adjusting the Steering Wheel

#### **⚠ WARNING**

Adjusting the steering wheel position while driving may cause you to lose control of the vehicle and be seriously injured in a crash.

Adjust the steering wheel only when the vehicle is stopped.

## Interior Rearview Mirror

Adjust the angle of the rearview mirror when you are sitting in the correct driving position.

### Rearview Mirror with Day and Night Positions\*

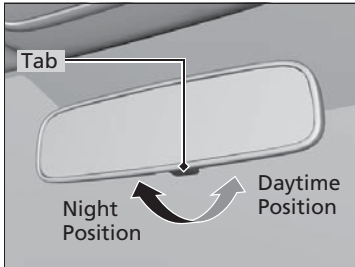

Flip the tab to switch the position. The night position will help to reduce the glare from headlights behind you when driving after dark.

### Automatic Dimming Rearview Mirror\*

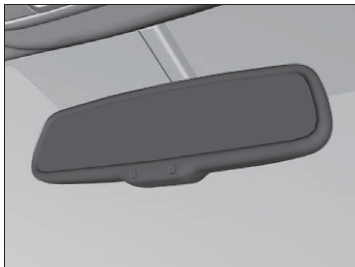

When you are driving after dark, the automatic dimming rearview mirror reduces the glare from headlights behind you, based on inputs from the mirror sensor. This feature is always active.

#### Mirrors

Keep the inside and outside mirrors clean and adjusted for best visibility.

Adjust the mirrors before you start driving.

**Front Seats** P. 175

#### Automatic Dimming Rearview Mirror\*

The auto dimming function cancels when the transmission is in **R**.

## Power Door Mirrors

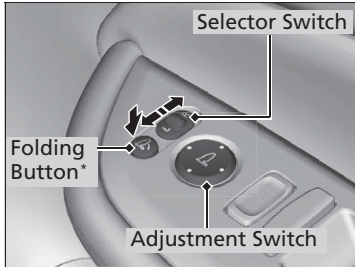

You can adjust the door mirrors when the power mode is in ON.

### ■ Mirror position adjustment

**L/R selector switch:** Select the left or right mirror. After adjusting the mirror, return the switch to the centre position.

**Mirror position adjustment switch:** Press the switch left, right, up, or down to move the mirror.

### ■ Folding door mirrors\*

Press the folding button to fold in and out the door mirrors.

\* Not available on all models

## ■ Automatic Folding Door Mirror Function\*

### ■ Folding in the door mirrors

Press the lock button on the remote transmitter, or press the door lock button on the front door.

- ▶ The mirrors start folding in automatically.

### ■ Folding out the door mirrors

Unlock the driver's door using the remote transmitter or keyless access system.

- ▶ The mirrors start folding out automatically.

## ⌘ Automatic Folding Door Mirror Function\*

You cannot turn the automatic folding out automatically if they have been folded in using the folding button.

You can turn the automatic folding door mirror function on and off.

⌘ **Settings** P. 116

Door mirrors will not fold automatically when locking from inside the vehicle using lock tab or master door lock switch.



## Front Seats

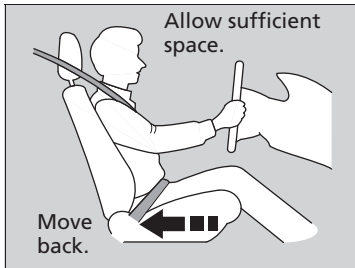

Adjust the driver's seat as far back as possible while allowing you to maintain full control of the vehicle. You should be able to sit upright, well back in the seat and be able to adequately press the pedals without leaning forward, and grip the steering wheel comfortably. The passenger's seat should be adjusted in a similar manner, so that it is as far back from the front airbag in the dashboard as possible.

### Seats

Always make seat adjustments before driving.

### Front Seats

## **⚠ WARNING**

**Sitting too close to a front airbag can result in serious injury or death if the front airbags inflate.**

**Always sit as far back from the front airbags as possible while maintaining control of the vehicle.**

In addition to the seat adjustment, you can adjust the steering wheel up and down, in and out. Allow at least 25 cm between the centre of the steering wheel and the chest.

Once a seat is adjusted correctly, rock it back and forth to make sure it is locked in position.

## ■ Adjusting the Seat Positions

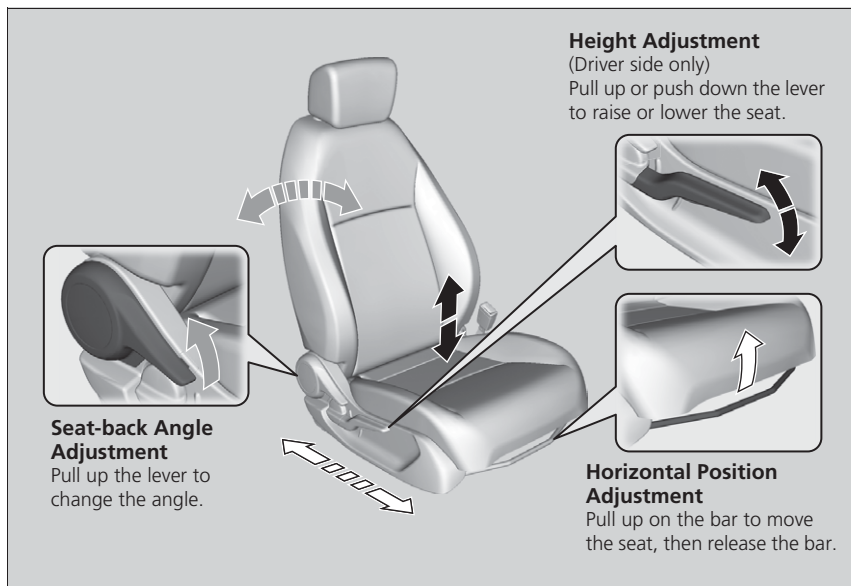

## ■ Adjusting the Seat-Backs

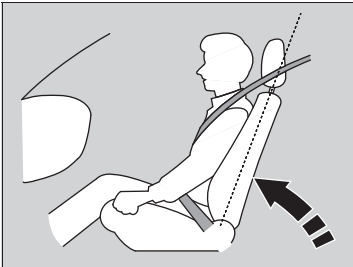

Adjust the driver's seat-back to a comfortable, upright position, leaving ample space between your chest and the airbag cover in the centre of the steering wheel.

The front seat passenger should also adjust their seat-back to a comfortable, upright position.

Reclining a seat-back so that the shoulder part of the belt no longer rests against the occupant's chest reduces the protective capability of the belt. It also increases the chance of sliding under the belt in a crash and being seriously injured. The farther a seat-back is reclined, the greater the risk of injury.

## ▶▶ Adjusting the Seat-Backs

### ⚠ WARNING

Reclining the seat-back too far can result in serious injury or death in a crash.

Adjust the seat-back to an upright position, and sit well back in the seat.

Do not put a cushion, or other object, between the seat-back and your back.

Doing so may interfere with proper seat belt or airbag operation.

If you cannot get far enough away from the steering wheel and still reach the controls, we recommend that you investigate whether some type of adaptive equipment may help.

## Head Restraints

Your vehicle is equipped with head restraints in both front seating positions.

### ■ Adjusting the Front Head Restraints

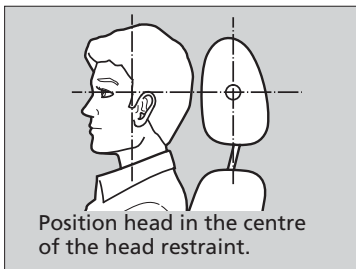

Head restraints are most effective for protection against whiplash and other rear-impact crash injuries when the centre of the back of the occupant's head rests against the centre of the restraint. The tops of the occupant's ears should be level with the centre height of the restraint.

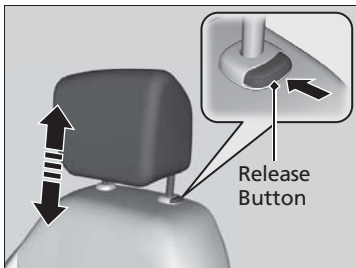

**To raise the head restraint:** Pull it upward.

**To lower the head restraint:** Push it down while pressing the release button.

### ► Adjusting the Front Head Restraints

#### **⚠ WARNING**

**Improperly positioning head restraints reduces their effectiveness and increases the likelihood of serious injury in a crash.**

**Make sure head restraints are in place and positioned properly before driving.**

In order for the head restraint system to work properly:

- Do not hang any items on the head restraints, or from the restraint legs.
- Do not place any objects between an occupant and the seat-back.
- Install each restraint in its proper location.

## ■ Removing and Reinstalling the Front Head Restraints

Head restraints can be removed for cleaning or repair.

### To remove the head restraint:

Pull the restraint up as far as it will go. Then push the release button, and pull the restraint up and out.

### To reinstall the head restraint:

Insert the legs back in place, then adjust the head restraint to an appropriate height while pressing the release button. Pull up on the restraint to make sure it is locked in position.

## ⌘ Removing and Reinstalling the Front Head Restraints

### **WARNING**

Failure to reinstall, or correctly reinstall, the head restraints can result in severe injury during a crash.

Always replace the head restraints before driving.

## Maintain a Proper Sitting Position

After all occupants have adjusted their seats and head restraints\*, and put on their seat belts, it is very important that they continue to sit upright, well back in their seats, with their feet on the floor, until the vehicle is safely parked and the engine is off.

Sitting improperly can increase the chance of injury during a crash. For example, if an occupant slouches, lies down, turns sideways, sits forward, leans forward or sideways, or puts one or both feet up, the chance of injury during a crash is greatly increased.

In addition, an occupant who is out of position in the front seat can be seriously or fatally injured in a crash by striking interior parts of the vehicle or being struck by an inflating front airbag.

### ► Maintain a Proper Sitting Position

#### **WARNING**

Sitting improperly or out of position can result in serious injury or death in a crash.

Always sit upright, well back in the seat, with your feet on the floor.

## Rear Seats

### Folding Down the Rear Seats\*

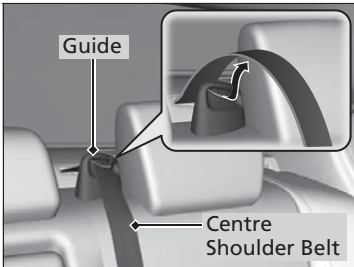

1. Remove the centre shoulder belt from the guide.

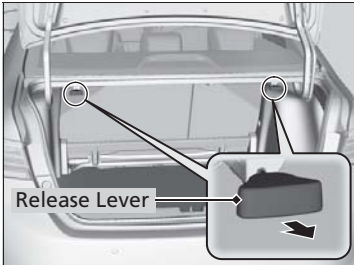

2. Pull the release lever in the boot to release the lock.

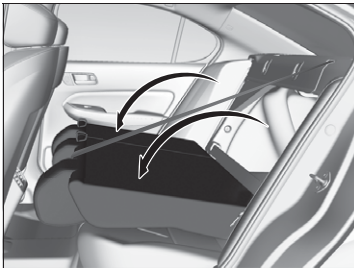

3. Fold the seat-back down.

### Folding Down the Rear Seats\*

#### **⚠ WARNING**

**Make sure the seat-backs are latched securely before driving.**

The rear seat-backs can be folded down to accommodate bulkier items in the boot.

Never drive with the seat-back folded down and the boot lid open.

**⚠ Exhaust Gas Hazard P. 84**

To lock the seat-back upright, push it backwards until it locks.

When returning the seat-back to its original position, push it firmly back. Also, make sure all rear shoulder belts are positioned in front of the seat-back, and the centre shoulder belt is re-positioned in the guide.

**Make sure all items in the boot or items extending through the opening into the rear seats are properly secured. Loose items can fly forward if you have to brake hard.**

\* Not available on all models

## Armrest\*

### ■ Using the Front Seat Armrest\*

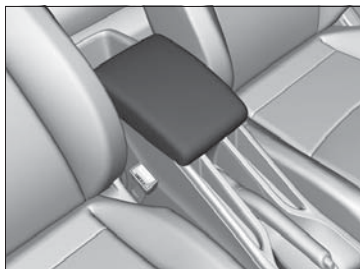

The console lid can be used as an armrest.

### ■ Using the Rear Seat Armrest\*

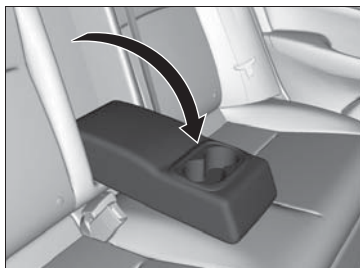

Pull down the armrest in the centre backrest.



## Interior Lights

### Interior Light Switches

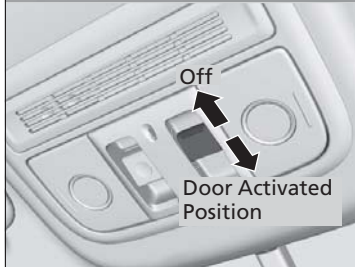
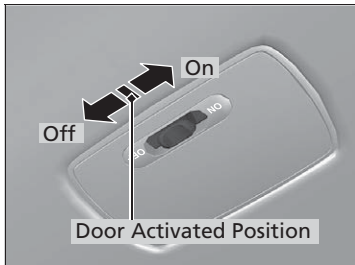

#### ■ ON

The interior light comes on regardless of whether the doors are open or closed.

#### ■ Door activated

The interior light comes on in the following situations:

- When any doors are opened.
- You unlock the driver's door.
- When the power mode is set to VEHICLE OFF (LOCK).

#### ■ OFF

The interior light remains off regardless of whether the doors are open or closed.

### Interior Light Switches

In the door activated position, the interior light fades out and goes off about 30 seconds after the doors are closed.

The light goes off after 30 seconds in the following situations:

- When you unlock the driver's door but do not open it.
- When you set the power mode to VEHICLE OFF (LOCK), but do not open a door.

#### Models with driver information interface

You can change the interior lights dimming time.

➤ **Settings** P. 116

The interior light goes off immediately in the following situations:

- When you lock the driver's door.
- When you close the driver's door in ACCESSORY mode.
- When you set the power mode to ON.

If you leave any of the doors open in VEHICLE OFF (LOCK) mode, the interior light goes off after about 15 minutes.

To avoid draining the battery, do not leave the interior light on for an extended length of time when the engine is off.

## ■ Map Lights

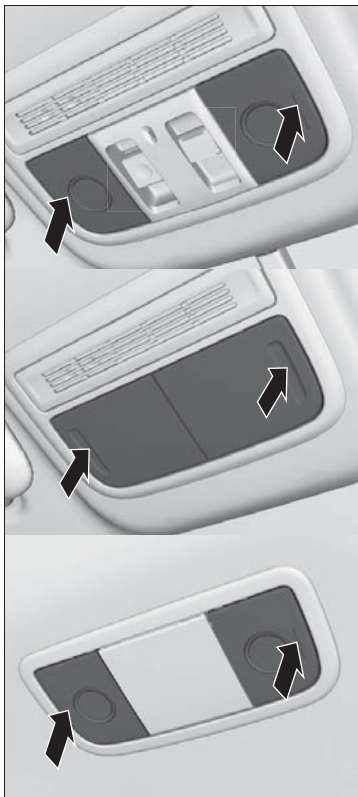

The map lights can be turned on and off by pressing the lenses.

## ▣ Map Lights

When the front interior light switch is in the door activated position and any door is open, the map light will not go off when you press the lens.

## Storage Items

### ■ Glove Box

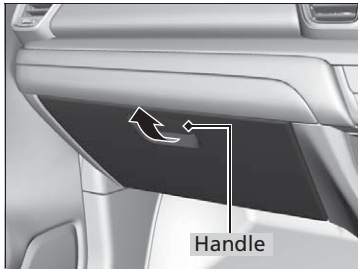

Pull the handle to open the glove box.

### ■ Console Compartment\*

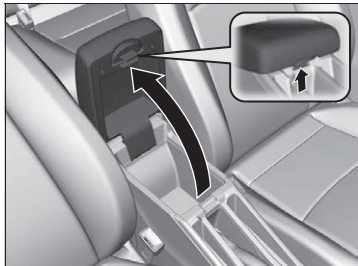

Pull the handle to open the console compartment.

### » Glove Box

#### **⚠ WARNING**

An open glove box can cause serious injury to your passenger in a crash, even if the passenger is wearing the seat belt.

Always keep the glove box closed while driving.

\* Not available on all models

*Continued*

## ■ Beverage Holders



■ Front seat beverage holders

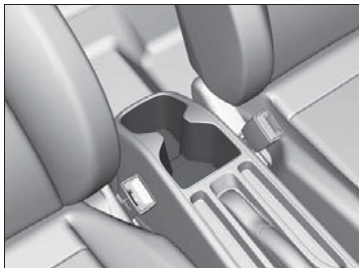

■ Front seat beverage holders (four beverage holders type)\*

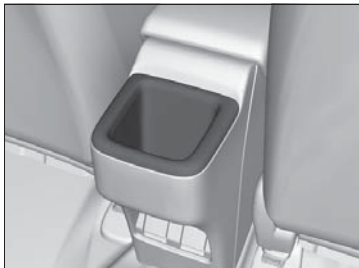

■ Rear seat beverage holder\*

## ►► Beverage Holders

### NOTICE

Spilled liquids can damage the upholstery, carpeting, and electrical components in the interior.

Be careful when you are using the beverage holders. Hot liquid can scald you.

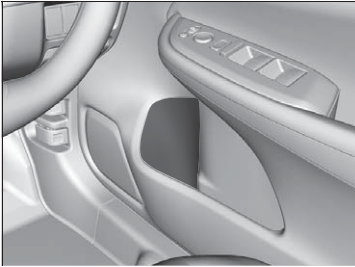

■ **Front door side beverage holders**

Are located on the both of front door side pockets.

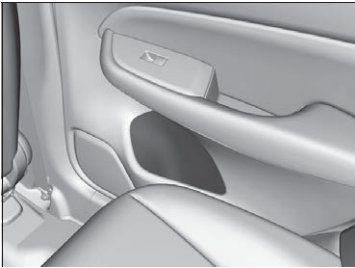

■ **Rear door side beverage holders**

Are located on the both of rear door side pockets.

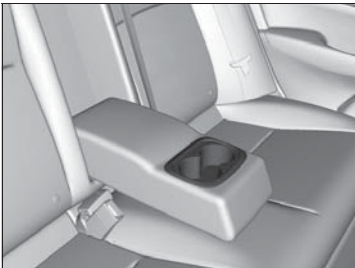

■ **Rear seat beverage holders\***

Fold the armrest down to use the rear seat beverage holders.

\* Not available on all models

### ■ Driver's Side Pocket

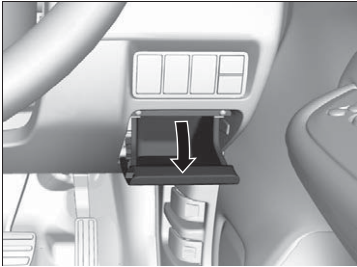

Pull the lid to open the pocket.

### ■ Coat Hook\*



There is a coat hook on the rear right grab handle of right side. Pull it down to use it.

### ☒ Coat Hook\*

The coat hook is not designed for large or heavy items.

## Other Interior Convenience Items

### ■ Accessory Power Sockets

The accessory power sockets can be used when the power mode is in ACCESSORY or ON.

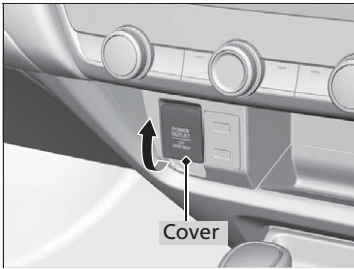

#### ■ Accessory power socket on the console panel

Open the cover to use it.

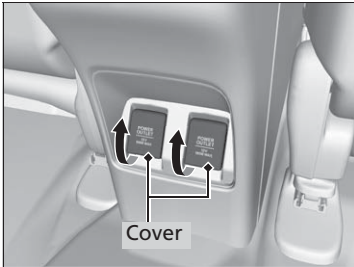

#### ■ Accessory power sockets on the back of the console compartment\*

Open the cover to use it.

### ⌘ Accessory Power Sockets

#### NOTICE

Do not insert an automotive type cigarette lighter element. This can overheat the power socket.

The accessory power sockets are designed to supply power for 12-volt DC accessories that are rated 180 watts or less (15 amps).

To prevent battery drain, use the power socket only when the engine is running.

When the accessory power socket is not in use, close the cover to prevent any small foreign objects from getting into the power socket.

\* Not available on all models

## ■ Rear Sunshade\*

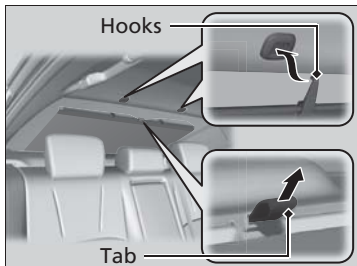

Pull the tab and roll up the sunshade all the way. Use the hooks to hang it.

## » Rear Sunshade\*

### NOTICE

Be careful not to scratch the heating elements on the rear windscreen when using the rear sunshade.

### Indian Models





Do not use the sunshade while driving as it could obstruct the driver's view.

The sunshade can be used to protect the interior when parking the car in direct sunlight for a long period of time.

Check and follow your local legal requirements before using the sunshade.



## Using Vents and A/C

-  Dashboard vents and back of the console compartment
-  Dashboard and floor vents, and back of the console compartment
-  Floor vents
-  Floor and demister vents

**Temperature Control Dial**  
Adjusts the interior temperature.

**MAX COOL Button**  
Press to cool down the interior rapidly.

**A/C (Air Conditioning) Button**  
Press to cool the interior or dehumidify.

**Mode Control Dial**  
Change airflow.

**ON/OFF (ON/OFF) Button**  
Press to switch the system between on and off.

**Fan Control Dial**  
Adjusts the fan speed.



**(Recirculation) Button**  
Press the  button and switch the mode depending on environmental conditions.

Recirculation mode (indicator on):  
Recirculates air from the vehicle's interior through the system.

Fresh air mode (indicator off):  
Maintains outside ventilation. Keep the system in fresh air mode in normal situations.

\* Not available on all models

## ■ Cooling

1. Adjust the fan speed using the fan control dial.
2. Select .
3. Adjust the temperature using the temperature control dial.
4. Press the **A/C** button (**A/C ON** is appeared).
5. Press the  button (the indicator off).

## » Cooling

### Continuously variable transmission models



While **ECON** mode is active, the system may have reduced cooling performance.

If the interior is very warm, you can cool it down more rapidly by partially opening the windows, press the **MAX COOL** button.

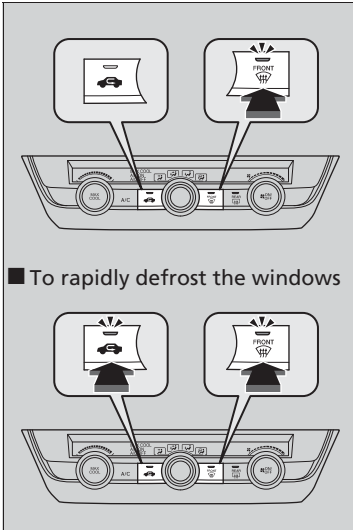
## ■ Defrosting the Windscreen and Windows



### ■ To rapidly defrost the windows

1. Set the fan to a high speed.
  2. Press the  button.
  3. Press the  button (indicator off).
  4. Adjust the temperature until the airflow feels cool.
- If you want to rapidly defrost the window:  
Set the fan to the maximum speed and lowest temperature, then press the  button (indicator on).

### ►► Defrosting the Windscreen and Windows

**For your safety, make sure you have a clear view through all the windows before driving.**

Do not set the temperature near the lower limit. When cold air hits the windscreen, the outside of the windscreen may fog up.

### ►► To rapidly defrost the windows

After defrosting the windows, switch over to fresh air mode. If you keep the system in recirculation mode, the windows may fog up from humidity. This impedes visibility.

## Using Automatic Climate Control

The automatic climate control system maintains the interior temperature you select. The system also selects the proper mix of heated\* or cooled air that raises\* or lowers the interior temperature to your preference as quickly as possible.

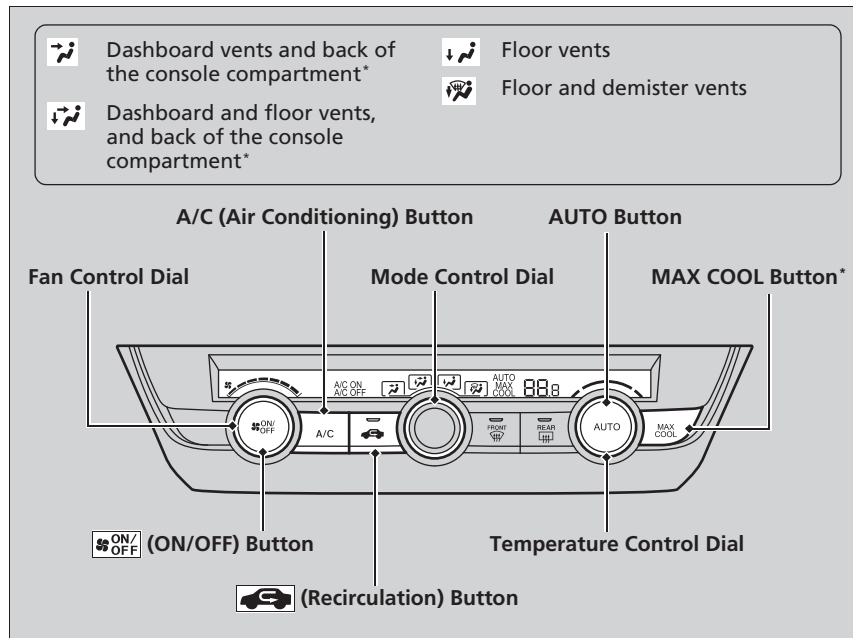

Use the system when the engine is running.

1. Press the **AUTO** button.
2. Adjust the interior temperature using the temperature control dial.
3. Press the **(ON/OFF)** button to cancel.

### Using Automatic Climate Control

If any buttons are pressed while using the climate control system in auto, the function of the button that was pressed will take priority. The **AUTO** indicator will go off, but functions unrelated to the button that was pressed will be controlled automatically.

### Continuously variable transmission models

While ECON mode is active, the climate control system may have reduced cooling performance.

### Models with MAX COOL button

If the interior is very warm, you can cool it down more rapidly by partially opening the windows, press the **MAX COOL** button.

When you set the temperature to the lower or upper\* limit, **Lo** or **Hi\*** is displayed.

Pressing the **(ON/OFF)** button switches the climate control system between on and off. When turned on, the system returns to your last selection.

### African, Indian, Bhutanese, Nepalese and Sri Lankan models

To prevent cold air from blowing in from outside, the fan may not start immediately when the **AUTO** button is pressed.

### ■ Switching between the recirculation and fresh air modes

Press the  (Recirculation) button and switch the mode depending on environmental conditions.

Recirculation mode (indicator on): Recirculates air from the vehicle's interior through the system.

Fresh air mode (indicator off): Maintains outside ventilation. Keep the system in fresh air mode in normal situations.

## ■ Defrosting the Windscreen and Windows

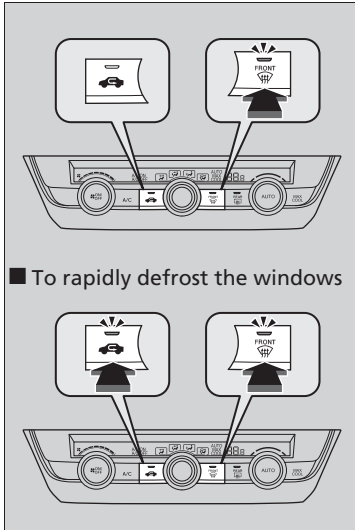

### ■ To rapidly defrost the windows

Pressing the  button to turn the air conditioning system on and automatically switches the system to fresh air mode.

#### Except African and Latin American models

Press the  button (indicator off) to switch to the fresh air mode.

► If you want to rapidly defrost the window:

Press the  button (indicator on).

Press the  button again to turn it off and the system will return to the previous settings.

## ►► Defrosting the Windscreen and Windows

**For your safety, make sure you have a clear view through all the windows before driving.**

Do not set the temperature near the lower limit. When cold air hits the windscreen, the outside of the windscreen may fog up.

## ►► To rapidly defrost the windows

After defrosting the windows, switch over to fresh air mode. If you keep the system in recirculation mode, the windows may fog up from humidity. This impedes visibility.

## Automatic Climate Control Sensors

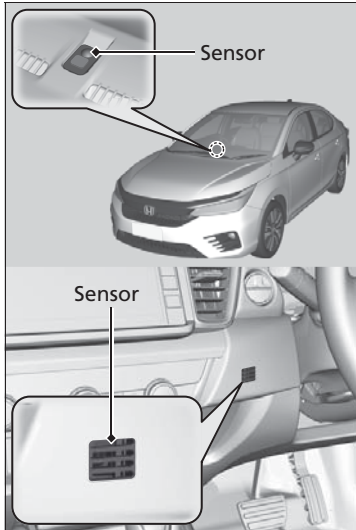

The automatic climate control system is equipped with sensors. Do not cover or spill any liquid on them.





# Features

If this vehicle is equipped with an audio system, please refer to the audio system manual.  
Consult a dealer for details.







# Driving

This chapter discusses driving and refueling.

## Before Driving

Driving Preparation .....	202
Load Limit .....	204

## Towing a Trailer..... 205

## When Driving

Starting the Engine .....	206
Precautions While Driving.....	213
Continuously Variable Transmission* .....	214

### Continuously variable transmission models

Shifting .....	215
----------------	-----

### Manual transmission models

Shifting .....	219
----------------	-----

ECON Mode* .....	221
Cruise Control* .....	222
Vehicle Stability Assist (VSA) System ..	228
Agile Handling Assist .....	230
Deflation Warning System* .....	231

## Braking

Brake System .....	235
Anti-lock Brake System (ABS) .....	237
Brake Assist System.....	238
Emergency Stop Signal.....	239

## Parking Your Vehicle

When Stopped.....	240
-------------------	-----

Parking Sensor System* .....	242
------------------------------	-----

## Refueling

### Petrol models

Fuel Information .....	246
------------------------	-----

### Diesel models

Fuel Information .....	247
How to Refuel .....	248

## Fuel Economy and CO<sub>2</sub> Emissions.... 249

\* Not available on all models

## Driving Preparation

Check the following items before you start driving.

### Exterior Checks

- Make sure there are no obstructions on the windows, door mirrors, exterior lights, or other parts of the vehicle.
  - ▶ Remove any frost, snow, or ice.
  - ▶ Remove any snow on the roof, as this can slip down and obstruct your field of vision while driving. If frozen solid, remove ice once it has softened.
  - ▶ When removing ice from around the wheels, be sure not to damage the wheel or wheel components.
- Make sure the bonnet is securely closed.
  - ▶ If the bonnet opens while driving, your front view will be blocked.
- Make sure the tyres are in good condition.
  - ▶ Check air pressures, and check for damage and excessive wear.
    - ✦ **Checking and Maintaining Tyres** P. 296
- Make sure there are no people or objects behind or around the vehicle.
  - ▶ There are blind spots from the inside.

### Exterior Checks

#### NOTICE

When doors are frozen shut, use warm water around the door edges to melt any ice. Do not try to force them open, as this can damage the rubber trim around the doors. When done, wipe dry to avoid further freezing.

Do not pour warm water into the key cylinder. You will be unable to insert the key if the water freezes in the hole.

Heat from the engine and exhaust can ignite flammable materials left under the bonnet, causing a fire. If you've parked your vehicle for an extended period, inspect and remove any debris that may have collected, such as dried grass and leaves that have fallen or have been carried in for use as a nest by a small animal. Also check under the bonnet for leftover flammable materials after you or someone else has performed maintenance on your vehicle.

## Interior Checks

- Store or secure all items on board properly.
  - ▶ Carrying too much luggage, or improperly storing it, can affect your vehicle's handling, stability, stopping distance, and tyres, and make it unsafe.
    - **Load Limit** P. 204
- Do not pile items higher than the seat height.
  - ▶ They can block your view and may be thrown forward in the event of sudden braking.
- Do not place anything in the front seat footwells. Make sure to secure the floor mat.
  - ▶ An object or unsecured floor mat can interfere with your brake and accelerator pedal operation while driving.
- If you have any animals on board, do not let them move around in the vehicle.
  - ▶ They may interfere with driving and a crash could occur.
- Securely close all doors and the boot.
- Adjust your seating position properly.
  - ▶ Adjust the head restraint, too.
    - **Seats** P. 175
    - **Adjusting the Front Head Restraints** P. 178
- Adjust the mirrors and steering wheel properly.
  - ▶ Adjust them while sitting in the proper driving position.
    - **Mirrors** P. 172
    - **Adjusting the Steering Wheel** P. 171

## Interior Checks

The headlight aim is set by the factory, and does not need to be adjusted. However, if you regularly carry heavy items in the boot, have the aiming readjusted at a dealer or by a qualified technician.

### Models with headlight adjuster

You can adjust the low beam headlight angle by yourself.

- **Headlight Adjuster\*** P. 164

\* Not available on all models

- Be sure items placed on the floor behind the front seats cannot roll under the seats.
  - ▶ They can interfere with the driver's ability to operate the pedals, or the operation of the seats.
- Everyone in the vehicle must fasten their seat belt.
  - ✦ **Fastening a Seat Belt** P. 39
- Make sure that the indicators in the instrument panel come on when you start the vehicle, and go off soon after.
  - ▶ Always have a dealer check the vehicle if a problem is indicated.
    - ✦ **Indicators** P. 88

## Load Limit

When you load luggage, the total weight of the vehicle, all passengers, and luggage must not exceed the maximum permissible weight.

✦ **Specifications** P. 364

✦ Load Limit

### **WARNING**

Overloading or improper loading can affect handling and stability and cause a crash in which you can be hurt or killed.

Follow all load limits and other loading guidelines in this manual.

## Towing a Trailer

---

Your vehicle is not designed to tow a trailer. Attempting to do so can void your warranties.

## Starting the Engine

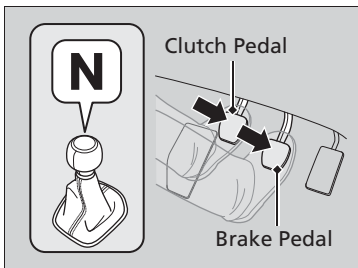
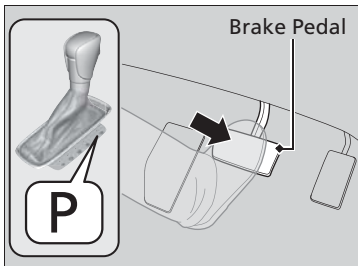
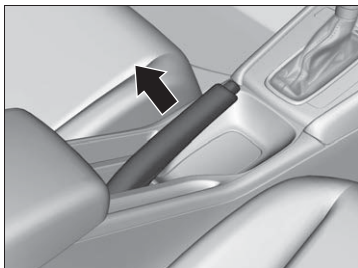

1. Make sure the parking brake is applied.

### Continuously variable transmission models

2. Check that the transmission is in **P**, then depress the brake pedal.

▶ Although it is possible to start the vehicle in **N**, it is safer to start it in **P**.

### Manual transmission models

2. Check that the shift lever is in **N**. Then depress the brake pedal with your right foot, and the clutch pedal with your left foot.

▶ The clutch pedal must be fully depressed to start the engine.

### Starting the Engine

Keep your foot firmly on the brake pedal when starting the engine.

The engine is harder to start in cold weather and in thinner air found at altitudes above 2,400 metres.

When starting the engine in cold weather, turn off all electrical accessories such as the lights, cooling system\*/climate control system\*, and rear demister in order to reduce battery drain.

If the exhaust system sounds abnormal or you can smell exhaust gas inside the vehicle, have your vehicle checked by a dealer. There may be a problem with the engine or exhaust system.

Bring the keyless remote close to the **ENGINE START/STOP** button if the battery in the keyless remote is weak.

▶ **If the Keyless Remote Battery is Weak** P. 331



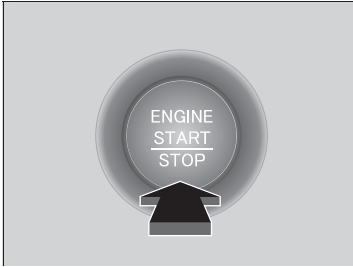

#### All models

3. Press the **ENGINE START/STOP** button without depressing the accelerator pedal.

#### Diesel models

- ▶ If the glow plugs indicator comes on, keep the clutch pedal fully depressed and wait until the indicator goes off. The engine starts automatically.

#### Starting the Engine

The engine may not start if the keyless remote is subjected to strong radio waves.

Do not hold the **ENGINE START/STOP** button to start the engine.

If the engine does not start, wait at least 30 seconds before starting the engine again.

The immobilizer system protects your vehicle from theft. If an improperly coded device is used, the engine's fuel system is disabled.

➤ **Immobilizer System** P. 149

#### Diesel models

When the engine malfunctions or stalls due to insufficient fuel, move the vehicle to a safe place immediately and refuel 10 Litres or more.

When fuel runs out, air enters the fuel system. This may cause slow starting of the engine.

If the engine does not start on the first try, try again a few times. If the engine still does not start, ask a dealer.

## ■ Stopping the Engine

You can turn the engine off when the vehicle is completely stopped.

### ■ Diesel models

Idle the engine for 10 seconds before turning off the engine.

### ■ Continuously variable transmission models

1. Put the transmission into **P**.
2. Press the **ENGINE START/STOP** button.

### ■ Manual transmission models

- If the shift lever is in **N**, press the **ENGINE START/STOP** button.
- If the shift lever is in any gear other than **N**, depress the clutch pedal, then press the **ENGINE START/STOP** button.

## » Stopping the Engine

### ■ Diesel models

When the ambient temperature is extremely low, the engine peak power may be restricted at starting the engine. This is to help the fuel flow for the normal engine operation.

### ■ Diesel models

For proper lubrication, the engine must not be run above fast idle speed until the low oil pressure indicator\* or low oil pressure warning message\* goes off.

Avoid harsh acceleration or labouring the engine before the normal operating temperature has been reached.

## ■ Remote Engine Start\*

You can remotely start the engine using the keyless remote.

### ■ To start the engine

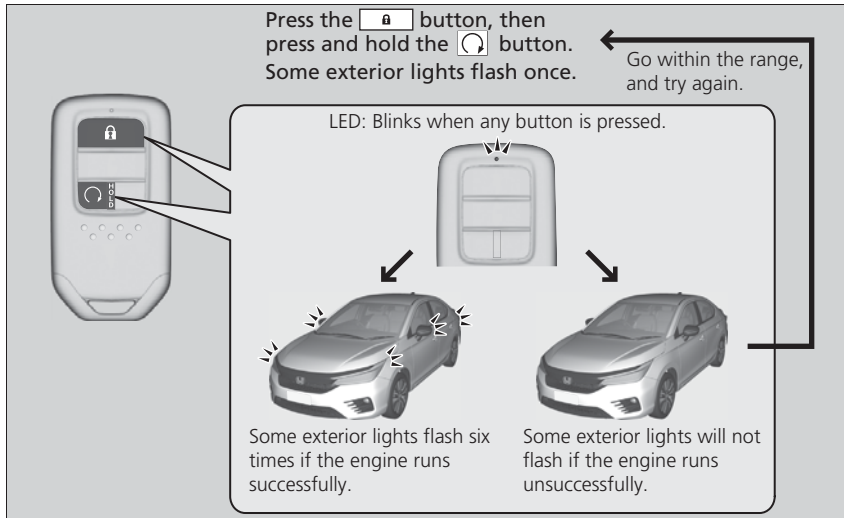

When started remotely, the engine automatically shuts off after 10 minutes of idling and/or the brake pedal and **ENGINE START/STOP** button have not been pressed simultaneously.

To extend the run time for another 10 minutes during the first run, press the button, then press and hold the button.

- ▶ Some exterior lights flash six times if a 10-minute extension request was transmitted successfully.

\* Not available on all models

Continued

## ▶▶ Remote Engine Start\*

### ⚠ WARNING

Engine exhaust contains toxic carbon monoxide.

Breathing carbon monoxide can kill you or cause unconsciousness.

Never use the remote engine starter when the vehicle is parked in a garage or other area with limited ventilation.

The remote engine start may violate local laws. Before using the remote engine start, check your local laws.

If there are buildings and obstacles between your vehicle and the remote, the range will be reduced. The range may be less when the vehicle is running. This distance may vary by external electrical interference.

The engine may not start by the remote engine start if:

- You have disabled a remote engine start setting using the driver information interface\*.
- ▶ **Settings** P. 116
- The power mode is not in VEHICLE OFF (LOCK).
- The transmission is in a position other than **P**.
- The bonnet is open, or any door or the boot is unlocked.

## ■ To stop the engine

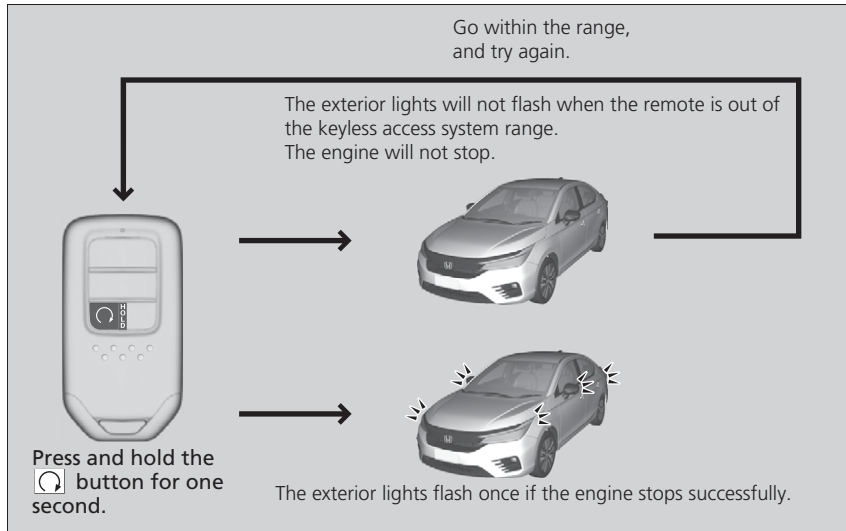

## ⊞ Remote Engine Start \*

- You have already used the remote twice to start the engine.
- Another registered keyless remote is in the vehicle.
- There is any antenna failure.
- The door is unlocked with the built-in key.
- The engine oil pressure is low.
- The engine coolant temperature is extremely high.
- The telematics unit malfunctions\*.
- The security system alarm is not set.

The engine may stop while it is running if:

- You do not start the vehicle within 10 minutes of starting the engine with the remote.
- The engine is stopped by using the remote.
- The security system alarm is not set.
- The door is unlocked with the built-in key.
- The bonnet is open, or any door, or the boot is unlocked.
- You press the shift lever release button.
- The engine coolant temperature is extremely high.
- The battery is low.
- The engine oil pressure is low.
- The malfunction indicator lamp comes on if there is a problem with the emissions control systems.

▶▶ Remote Engine Start\*

While the engine is running, the vehicle will automatically precondition inside the vehicle.

When it is warm outside:

- The cooling system\*/climate control system\* is activated in recirculation mode.

When it is cold outside:

- The demister is activated at a moderately warm temperature.
- The rear demister is activated.

\* Not available on all models

## Starting to Drive

### Continuously variable transmission models

When the engine was started using the keyless remote\*

1. Depress and hold the brake pedal, then press the **ENGINE START/STOP** button.

When the engine was started in any case

2. Keeping your right foot on the brake pedal, release the parking brake. Check that the parking brake and brake system indicator has gone off.

🔗 **Parking Brake** P. 235

3. Put the shift lever in **[D]**. Select **[R]** when reversing.

4. Gradually release the brake pedal and gently depress the accelerator pedal to pull away.

## Hill Start Assist System

Hill start assist keeps the brake engaged briefly to help to prevent the vehicle from rolling on inclines as you move your foot from the brake pedal to the accelerator.

### Manual transmission models

Depress the clutch pedal, and shift to one of the forward gears when facing uphill, or **[R]** when facing downhill, then release the brake pedal.

### Continuously variable transmission models

Put the transmission into **[D]** or **[S]** when facing uphill, or **[R]** when facing downhill, then release the brake pedal.

## Starting to Drive

### When the engine was started using the keyless remote\*

The engine stops when the transmission is taken out of **[P]** before the **ENGINE START/STOP** button is pressed. Follow step 1 when starting to drive.

## Hill Start Assist System

Hill start assist may not prevent the vehicle from rolling downhill on a very steep or slippery slope, and will not operate on small inclines.

Hill start assist will operate even when VSA is switched off.

Hill start assist is not a replacement for the parking brake.

## Precautions While Driving

### ■ In a Fog

Visibility becomes low when it is foggy. When you drive, turn on the low beam headlights even during the daytime. Slow down, using the road line in the centre, guard rails, and the taillights of the vehicle ahead of you as your driving guide.

### ■ In a Strong Wind

If a strong side wind drifts your vehicle while driving, hold the steering wheel tight. Slowly decelerate your vehicle and keep your vehicle in the middle of the road. Be careful with wind gusts especially when your vehicle is exiting a tunnel, driving on a bridge or river bank, and driving through an open area like a quarry, and when a large lorry is passing by.

### ■ In Rain

The road is slippery when raining. Avoid hard braking, rapid acceleration, and abrupt steering and be more cautious when driving. It is likely to experience hydroplaning phenomenon if you are driving on a rutted road with puddles. Do not drive in deep water and on flooded roads. This can damage the engine or driveline, or cause electrical component failure.

### ⌘ Precautions While Driving

**CAUTION:** Do not drive on the road where water is deep. Driving through deep water will cause damage to the engine and electrical equipment and the vehicle will break down.

#### NOTICE

Do not operate the shift lever while pressing the accelerator pedal. You could damage the transmission.

#### NOTICE

If you repeatedly turn the steering wheel at an extremely low speed, or hold the steering wheel in the full left or right position for a while, the electric power steering (EPS) system heats up. The system goes into a protective mode, and limits its performance. The steering wheel becomes harder and harder to operate. Once the system cools down, the EPS system is restored. Repeated operation under these conditions can eventually damage the system.

If the power mode is set to ACCESSORY while driving, the engine will shut down and all steering and brake power assist functions will stop, making it difficult to control the vehicle.

Do not select **[N]** while driving as you will lose engine braking (and acceleration) performance.

### ■ Other Precautions

If there is a strong impact with something under the vehicle, stop in a safe location. Check the underside of the vehicle for damage or any fluid leaks.

## Continuously Variable Transmission\*

### ■ Creeping

When the engine runs at higher idle speeds, the creeping force increases. Keep the brake pedal firmly depressed when stopped.

### ■ Kickdown

Quickly depressing the accelerator pedal while driving uphill may cause the transmission to drop to a lower ratio, unexpectedly increasing vehicle speed. Depress the accelerator pedal carefully, especially on slippery roads and curves.

### ⌘ Precautions While Driving

During the first 1,000 km of operation, avoid sudden acceleration or full throttle operation so as not to damage the engine or powertrain.

Avoid hard braking for the first 300 km. You should also follow this when the brake pads are replaced.

### ⌘ In Rain

Be careful when hydroplaning phenomenon occurs. When you drive on a road covered with water at excessive speed, a layer of water builds between the tyres and the road surface. If this occurs, the vehicle cannot respond to control inputs such as steering, and braking.

Slowly decelerate when you shift down. If the road is slippery, sudden engine braking can cause the tyres to skid.



## Continuously variable transmission models

**Shifting**

Change the shift position in accordance with your driving needs.

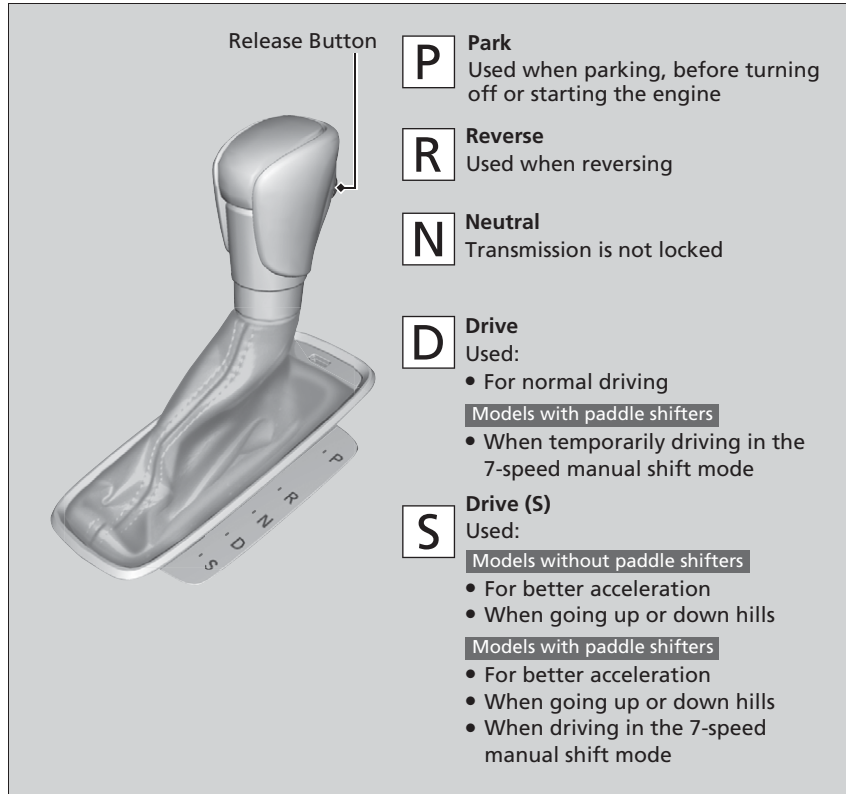
**■ Shift lever positions****▣ Shift lever positions**

You cannot change the power mode from ON to VEHICLE OFF (LOCK) unless the shift lever is in **P**.

The vehicle may move very slightly even in **N** while the engine is cold.

Depress the brake pedal firmly and, when necessary, apply the parking brake.

Continued

## Shift Lever Operation

### Models with driver information interface

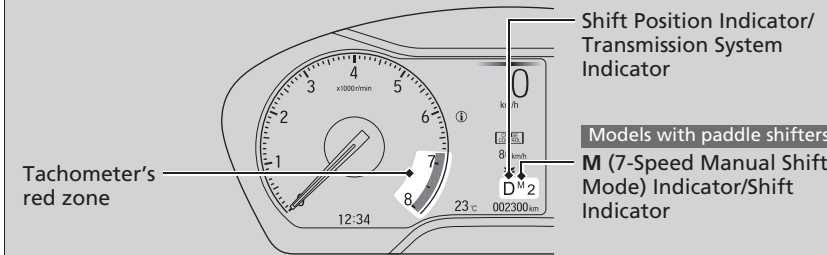

### Models with information display

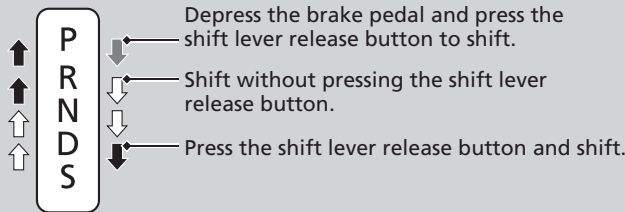
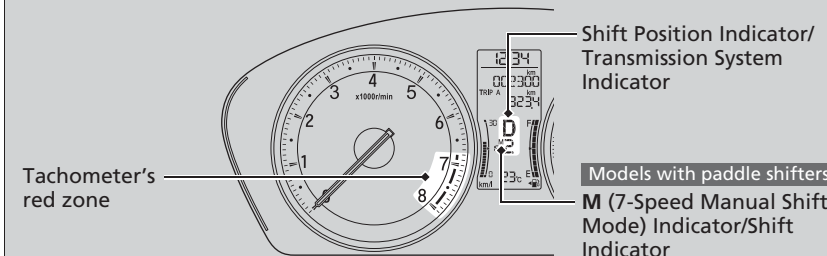

## Shift Lever Operation

### NOTICE

When you change the shift lever from **D** to **R** and vice versa, come to a complete stop and keep the brake pedal depressed. Operating the shift lever before the vehicle has come to a complete standstill can damage the transmission.

Use the shift position indicator to check the lever position before pulling away.

If the shift position indicator blinks when driving, in any shift position, there is a problem with the transmission. Avoid sudden acceleration and have the transmission checked by a dealer as soon as possible.

The fuel supply may be cut off if you drive at engine speeds in or over the tachometer's red zone (engine speed limit). If this happens, you may experience a slight jolt.

It may not be possible to operate the shift lever if the brake pedal is applied while the shift lever release button is held down. Depress the brake pedal first.

When shifting positions in extremely low temperatures (-30°C), there may be a short delay before the shift position is displayed. Always confirm you are in the correct shift position before driving.

## Models with paddle shifters

**7-Speed Manual Shift Mode**

Use the paddle shifters to change between 1st and 7th speeds without releasing your hands from the steering wheel. The transmission switches to the 7-speed manual shift mode when you pull a paddle shifter while driving. This mode is useful when engine braking is needed.

**■ When the shift lever is in [D]:**

The shift mode goes into the 7-speed manual shift mode temporarily, and the number is displayed in the shift indicator.

The 7-speed manual shift mode is cancelled automatically if you drive at constant speed or accelerate, and the number in the shift indicator goes off.

You can cancel this mode by pulling the [+] paddle shifter for a few seconds.

The 7-speed manual shift mode is especially useful when reducing the vehicle speed temporarily before making a turn.

**■ When the shift lever is in [S]:**

The shift mode goes into the 7-speed manual shift mode. The **M** indicator and the speed number are displayed in the shift indicator. As the vehicle speed slows down, the transmission automatically shifts down accordingly. When the vehicle comes to a stop, it automatically shifts down into 1st.

If the vehicle speed increases and the engine speed reaches near the tachometer's red zone, the transmission automatically shifts up.

When cancelling the 7-speed manual shift mode, move the shift lever from [S] to [D]. When the 7-speed manual shift mode is cancelled, the **M** indicator and shift indicator will turn off.

## ■ 7-Speed Manual Shift Mode Operation

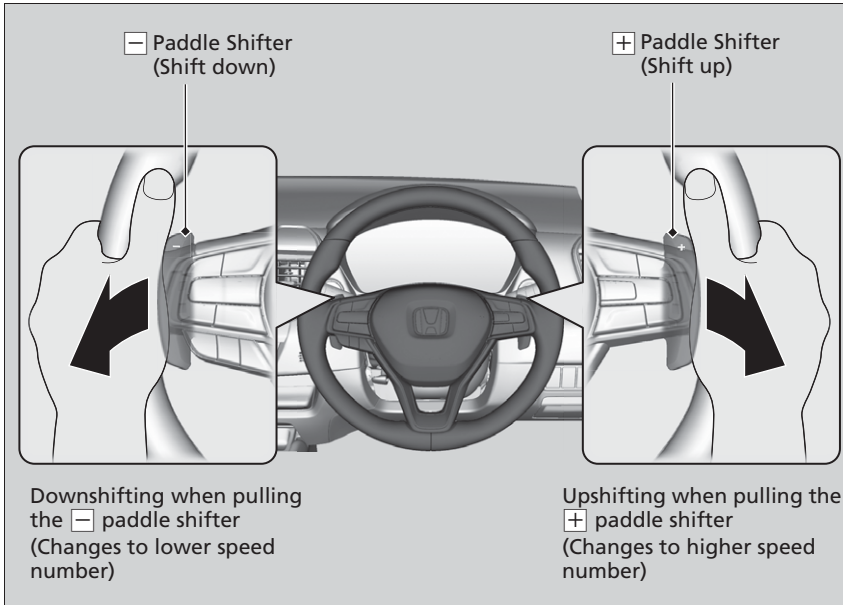

## ▶▶ 7-Speed Manual Shift Mode Operation

In the 7-speed manual shift mode, the transmission shifts up or down by operating either paddle shifter under the following conditions:

**Shift Up:** The engine speed reaches the lowest threshold of the higher speed position.

**Shift Down:** The engine speed reaches the highest threshold of the lower speed position.

When the engine speed reaches near the tachometer's red zone, the transmission shifts up automatically.

When the engine speed reaches the lowest threshold of the selected speed position, the transmission shifts down automatically.

Operating the paddle shifters on slippery surfaces may cause the tyres to lock up. In this case, the 7-speed manual shift mode is cancelled and goes back to the normal **D** driving mode.

Each paddle shift operation makes a single speed change.

To change continuously, release the paddle shifter before pulling it again for the next speed.

The shift indicator blinks when you cannot shift up or down. It indicates that your vehicle speed is not in its allowable shifting range.

Slightly accelerate to shift up and decelerate to shift down while the indicator is blinking.

## Manual transmission models

## Shifting

### Shift Lever Operation

Fully depress the clutch pedal to operate the shift lever and change gears, then slowly release the pedal.

Depress the clutch pedal, and pause for a few seconds before shifting into **[R]**, or shift into one of the forward gears for a moment. This stops the gears so they do not “grind.”

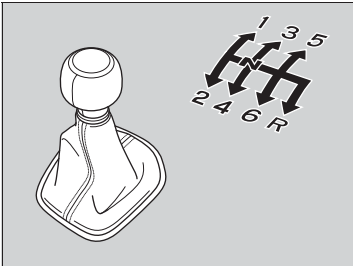

When you are not shifting, do not rest your foot on the clutch pedal. This can cause your clutch to wear out faster.

### Shifting

**NOTICE**

Do not shift to **[R]** before the vehicle comes to a complete stop. Shifting to **[R]** before stopping can damage the transmission.

**NOTICE**

Before downshifting, make sure the engine will not go into the tachometer's red zone. Should this occur, it can severely damage your engine.

If you exceed the maximum speed for the gear you are in, the engine speed will enter into the tachometer's red zone. When this happens, you may experience a slight jolt.

Continued

## ■ Reverse Lockout

The manual transmission has a lockout mechanism that stops you from accidentally shifting into **R** from a forward gear while the vehicle is moving above a certain speed.

If you cannot shift to **R** when the vehicle is stopped, do the following:

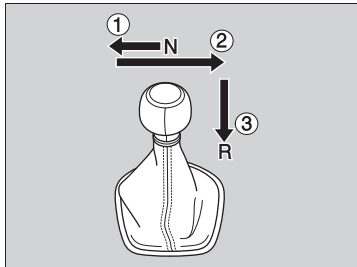

1. Depress the clutch pedal, move the shift lever all the way to the left, and shift to **R**.
2. If you still cannot shift into **R**, apply the parking brake, and set the power mode to ACCESSORY or VEHICLE OFF (LOCK).
3. Depress the clutch pedal and shift into **R**.
4. Keep depressing the clutch pedal and start the engine.

Have your vehicle checked by a dealer if you have to go through this procedure repeatedly.

## ECON Mode\*

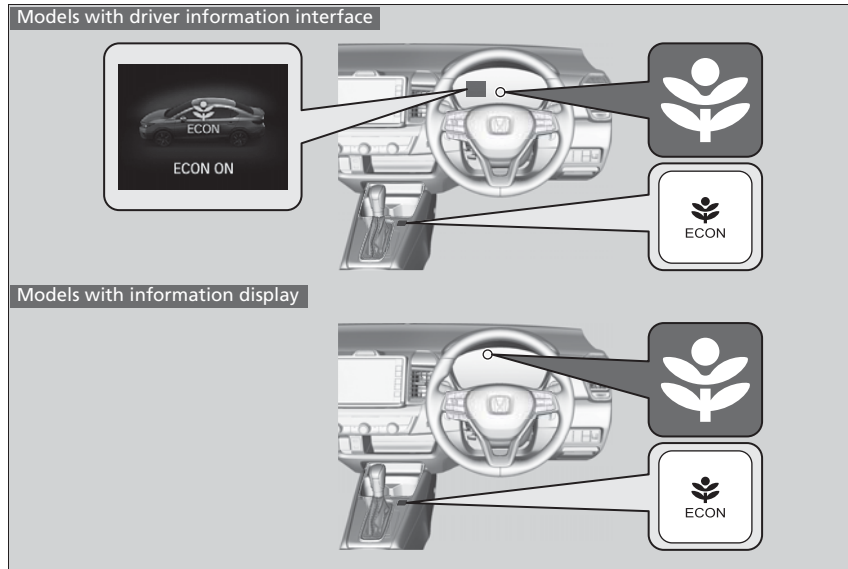

The **ECON** button turns the ECON mode on and off.  
 The ECON mode helps you to improve your fuel economy by adjusting the performance of the engine and cooling system\*/climate control system\*.

### ▶▶ ECON Mode\*

While in ECON mode, the cooling system\*/climate control system\* has greater temperature fluctuations.

The mode may not be able to be changed under some driving conditions. If mode change is necessary, reduce speed or cornering speed.

#### Models with driver information interface

This message will also appear if you try to change mode when there is a vehicle system failure.

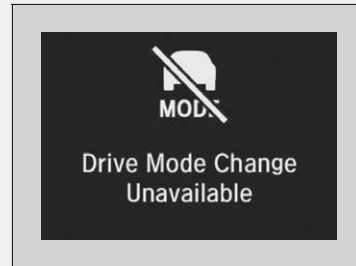

\* Not available on all models

## Cruise Control \*

Maintains a constant vehicle speed without having to keep your foot on the accelerator. Use cruise control on motorways or open roads where you can travel at a constant speed with little acceleration or deceleration.

### » Cruise Control \*

## WARNING

Improper use of the cruise control can lead to a crash.

Use the cruise control only when travelling on open motorways in good weather.

It may not be possible to maintain a constant speed when driving uphill or downhill.

When not using cruise control:  
Turn off cruise control by pressing the **CRUISE** button.

#### Manual transmission models

When the engine speed slows down, try to downshift.

You can maintain the set speed if you change gear within five seconds.

#### Models with ECON mode

While in ECON mode, it may take relatively more time to accelerate to maintain the set speed.



When to use

■ Vehicle speed for cruise control:  
Desired speed in a range above  
roughly 40 km/h ~

Continuously variable transmission  
models

■ Shift positions for cruise control:  
In **D** or **S**

Manual transmission models

■ Shift positions for cruise control:  
In **2** or higher position

Always keep sufficient distance  
between you and the vehicle in  
front of you.



How to use

Models with information display

**CRUISE MAIN** is on in the instrument panel.  
Cruise control is ready to use.

■ Press the **CRUISE** button  
on the steering wheel.

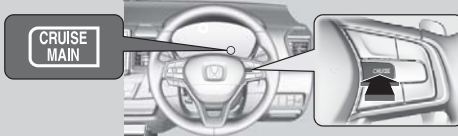

Models with driver information interface

**CRUISE MAIN** is on in the driver information interface.  
Cruise control is ready to use.

■ Press the **CRUISE** button  
on the steering wheel.



Continued

## ■ To Set the Vehicle Speed

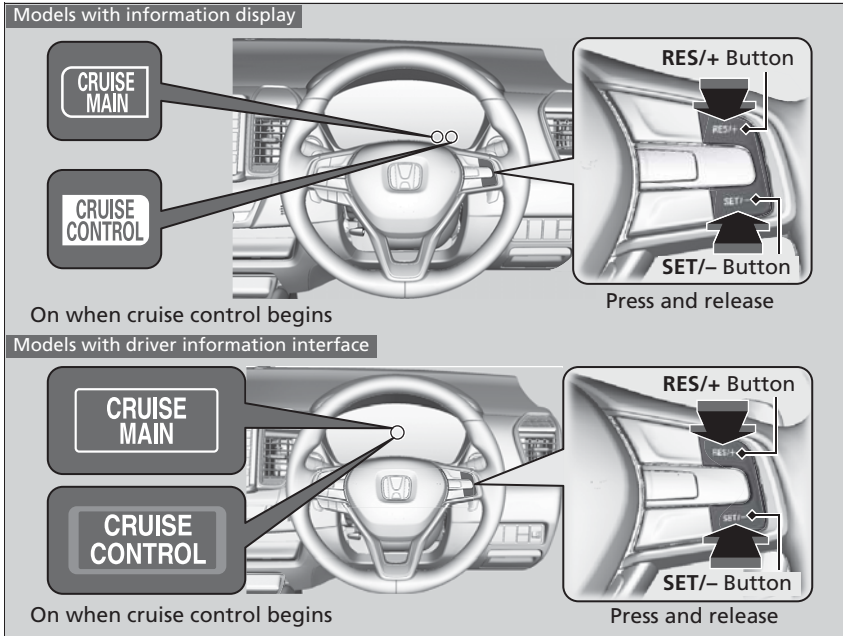

Take your foot off the pedal and press the **RES/+** or **SET/-** button when you reach the desired speed.

The moment you release the **RES/+** or **SET/-** button, the set speed is fixed, and cruise control begins. The **CRUISE CONTROL** indicator comes on.

## ■ To Adjust the Vehicle Speed

Increase or decrease the vehicle speed using the **RES/+** or **SET/-** buttons on the steering wheel.

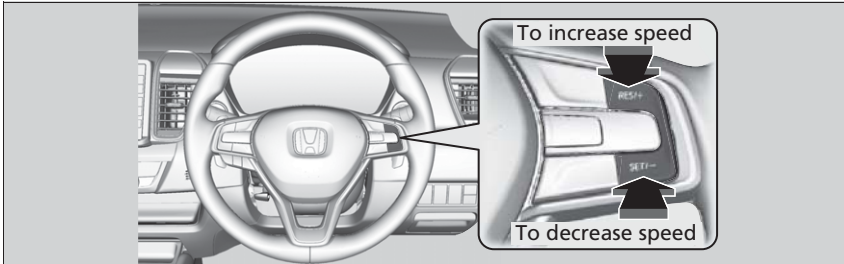

- Each time you press the button, the vehicle speed is increased or decreased by about 1.6 km/h.
- If you keep the button pressed, the vehicle speed increases or decreases until you release it. This speed is then set.

## ☒ To Adjust the Vehicle Speed

You can set the vehicle speed using the **SET/-** button on the steering wheel when adjusting the speed with the accelerator and brake pedals.

*Continued*

## ■ To Cancel

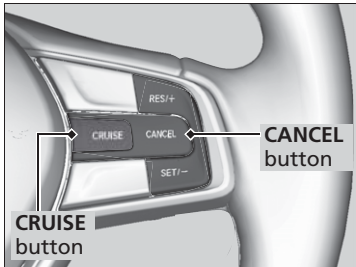

To cancel cruise control, do any of the following:

- Press the **CANCEL** button.
- Press the **CRUISE** button.
- Depress the brake pedal.

### Manual transmission models

- Depress the clutch pedal for five seconds or more.

The **CRUISE CONTROL** indicator goes off.

## ▶▶ To Cancel

### Models with driver information interface

Resuming the prior set speed:

After you have cancelled cruise control, you can activate the cruise control with the prior set speed displayed on the driver information interface (in gray) by pressing the **RES/+** button while driving at a speed of at least 40 km/h or more.

When you turn the cruise control off by pressing the **CANCEL** button or depressing the brake pedal, the prior set speed is displayed on the driver information interface in gray.

When pressing the **RES/+** button, the cruise control is activated with displayed speed.

Then, when the **CRUISE CONTROL** indicator is displayed and you press the **RES/+** button during the prior set speed (in gray) is not displayed, the current vehicle speed is set as same as the condition of operating the **SET/-** button.

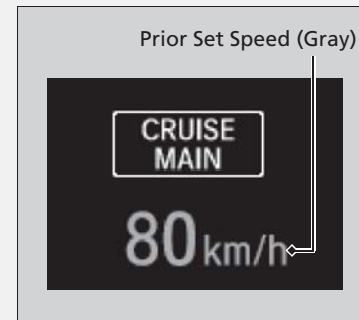

» To Cancel

**Models with information display**

Resuming the prior set speed:

After cruise control has been cancelled, you can still resume the prior set speed by pressing the **RES/+** button while driving at a speed of at least 40 km/h or more.

**All models**

You cannot set or resume in the following situations:

- When vehicle speed is less than 40 km/h
- When the **CRUISE** button is turned off

At vehicle speeds of 35 km/h or less, cruise control is cancelled automatically.

## Vehicle Stability Assist (VSA) System

VSA helps to stabilise the vehicle during cornering if the vehicle turns more or less than what was intended. It also assists in maintaining traction on slippery surfaces. It does so by regulating engine output and selectively applying the brakes.

### ▶▶ Vehicle Stability Assist (VSA) System

The VSA may not function properly if tyre type and size are mixed. Make sure to use the same size and type of tyre, and the air pressures as specified.

When the VSA system indicator comes on and stays on while driving, there may be a problem with the system. While this may not interfere with normal driving, have your vehicle checked by a dealer immediately.

VSA cannot enhance stability in all driving situations and does not control the entire braking system. You still need to drive and corner at speeds appropriate for the conditions and always leave a sufficient margin of safety.

The main function of the VSA system is generally known as Electronic Stability Control (ESC). The system also includes a traction control function.

The indicators for the Vehicle Stability Assist (VSA) System, Vehicle Stability Assist (VSA) OFF and Low Tyre Pressure/Deflation Warning System\* may come on after reconnecting the battery. Drive a short distance at more than 20 km/h. The indicator should go off. If it does not, have your vehicle checked by a dealer.

### ■ VSA Operation

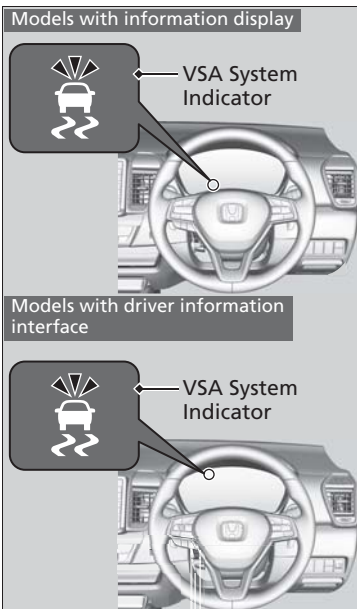

When VSA activates, you may notice that the engine does not respond to the accelerator. You may also notice some noise from the hydraulic brake system. You will also see the indicator blink.

## VSA On and Off

### Models with information display

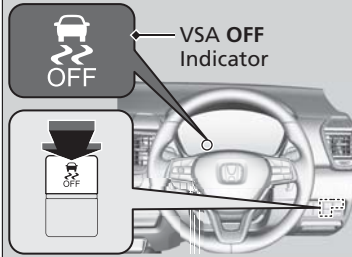

### Models with driver information interface

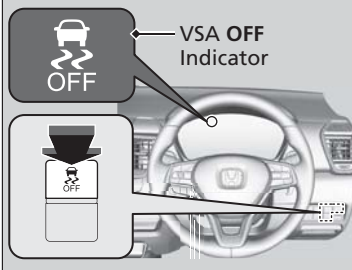

This button is on the driver side control panel. To partially disable VSA functionality/features, press and hold it until you hear a beep.

Your vehicle will have normal braking and cornering ability, but traction control function will be less effective.

To restore VSA functionality/features, press the  (VSA **OFF**) button until you hear a beep.

VSA is turned on every time you start the engine, even if you turned it off the last time you drove the vehicle.

### Vehicle Stability Assist (VSA) System

In certain unusual conditions when your vehicle gets stuck in shallow mud or fresh snow, it may be easier to free it with the VSA temporarily switched off.

When the  (VSA **OFF**) button is pressed, the traction control function becomes less effective. This allows for the wheels to spin more freely at low speed. You should only attempt to free your vehicle with the VSA off if you are not able to free it when the VSA is on.

Immediately after freeing your vehicle, be sure to switch VSA on again. We do not recommend driving your vehicle with the VSA system switched off.

You may hear a motor sound coming from the engine compartment while system checks are being performed immediately after starting the engine or while driving. This is normal.

## Agile Handling Assist

---

Lightly brakes the front wheels, as needed, when you turn the steering wheel, and helps support the vehicle's stability and performance during cornering.

### ⓘ Agile Handling Assist

The agile handling assist cannot enhance stability in all driving situations. You still need to drive and corner at speeds appropriate for the conditions and always leave a sufficient margin of safety.

When the VSA system indicator comes on and stays on while driving, the agile handling assist does not activate.

You may hear a sound coming from the engine compartment while the agile handling assist is activated. This is normal.



## Deflation Warning System\*

Instead of directly measuring the pressure in each tyre, the deflation warning system on this vehicle monitors and compares the rolling radius and rotational characteristics of each wheel and tyre while you are driving to determine if one or more tyres are significantly under-inflated.

### Models with driver information interface

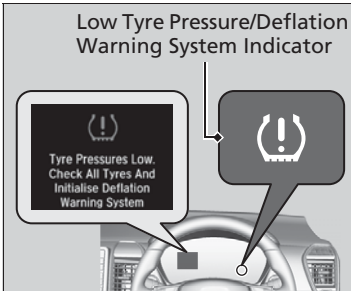

This will cause the low tyre pressure/deflation warning system indicator to come on and a message to appear on the driver information interface.

### Models with information display

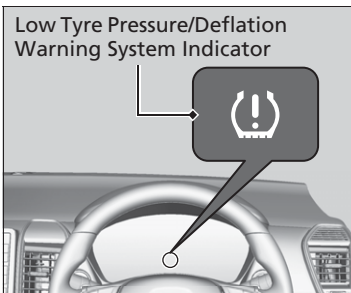

This will cause the low tyre pressure/deflation warning system indicator to come on.

### Deflation Warning System\*

The system does not monitor the tyres when driving at low speed.

Conditions such as low ambient temperature and altitude change directly affect tyre pressure and can trigger the low tyre pressure/deflation warning system indicator to come on.

Tyre pressure checked and inflated in:

- Warm weather can become under-inflated in colder weather.
- Cold weather can become over-inflated in warmer weather.

The low tyre pressure/deflation warning system indicator will not come on as a result of over inflation.

The deflation warning system may not function properly if tyre type and size are mixed.

Make sure to use the same size and type of tyre.

➤ **Checking and Maintaining Tyres** P. 296

The low tyre pressure/deflation warning system indicator may come on with a delay or may not come on at all when:

- You rapidly accelerate, decelerate, or turn the steering wheel.
- You drive on snowy or slippery roads.
- Tyre chains\* are used.

\* Not available on all models

## ■ Deflation Warning System Initialisation

You must start deflation warning system initialisation every time you:

- Adjust the pressure in one or more tyres.
- Rotate the tyres.
- Replace one or more tyres.

Before initialising the deflation warning system:

- Set the cold tyre pressure in all four tyres.  
    🔧 **Checking Tyres** P. 296

Make sure:

- The vehicle is at a complete stop.

### Continuously variable transmission models

- The shift lever is in **P**.

### Manual transmission models

- The shift lever is in **N**.

### All models

- The power mode is in ON.

## 🔧 Deflation Warning System\*

The low tyre pressure/deflation warning system indicator may come on under the following conditions:

- A compact spare tyre\* is used.
- Tyre chains\* are used.
- Deflation warning system cannot be initialised if a compact spare tyre\* is installed.
- The initialisation process requires approximately 30 minutes of cumulative driving at speeds between 40–100 km/h.
- During this period, if the engine is turned on and the vehicle is not moved within 45 seconds, you may notice the low tyre pressure/deflation warning system indicator comes on briefly. This is normal and indicates that the initialisation process is not yet complete.

If tyre chains\* are installed, remove them before initialising the deflation warning system.

If the low tyre pressure/deflation warning system indicator comes on even when the properly inflated specified regular tyres are installed, have your vehicle checked by a dealer.

We recommend that the tyres be replaced with the same brand, model, and size as the originals. Ask a dealer for details.

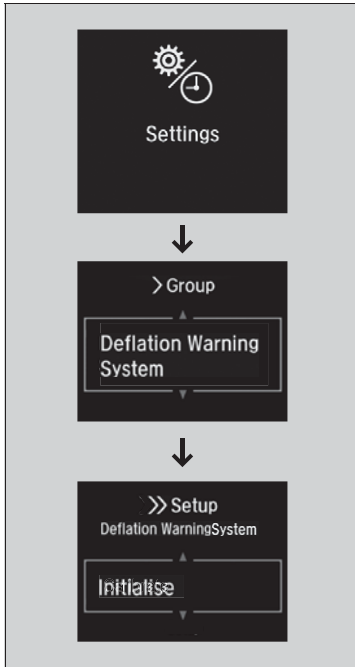

**Models with driver information interface**

You can initialise the system from the customized features on the driver information interface.

1. Press (home) button.
  2. Roll the left selector wheel controls to select , then push the left selector wheel.
    - ▶ appears on the display.
  3. Roll the left selector wheel controls to select **Deflation Warning System**, then push the left selector wheel.
    - ▶ The display switches to the customization setup screen, where you can select **Cancel** or **Initialise**.
  4. Roll the left selector wheel controls to select **Initialise**, then push the left selector wheel.
    - ▶ **Completed** screen appears, then the display returns to the customization setup screen.
- If the **Failed** message appears, repeat steps 3 – 4.
  - The initialisation process finishes automatically.

**Deflation Warning System\***

The indicators for the Vehicle Stability Assist (VSA) System, Vehicle Stability Assist (VSA) OFF and Low Tyre Pressure/Deflation Warning System\* may come on after reconnecting the battery. Drive a short distance at more than 20 km/h. The indicator should go off. If it does not, have your vehicle checked by a dealer.

\* Not available on all models

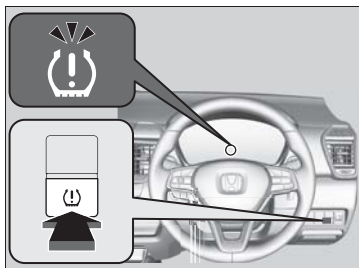

**Models with information display**

Press and hold the deflation warning system button until the low tyre pressure/deflation warning system indicator blinks twice, indicating the initialisation process has begun.

- If the low tyre pressure/deflation warning system indicator does not blink, confirm the above conditions then press and hold the deflation warning system button again.
- The initialisation process finishes automatically.

## Brake System

### ■ Parking Brake

Use the parking brake to keep the vehicle stationary when parking.

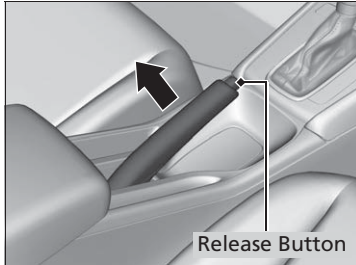

#### To apply:

Pull the lever fully up without pressing the release button.

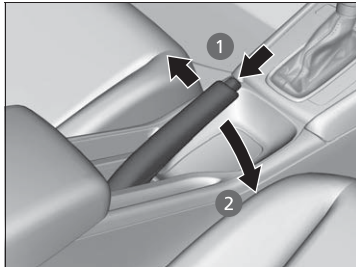

#### To release:

1. Pull the lever slightly, and press and hold the release button.
2. Lower the lever down all the way, then release the button.

### » Parking Brake

#### NOTICE

Release the parking brake fully before driving. The rear brakes and axle can be damaged if you drive with the parking brake applied.

If you start driving without fully releasing the parking brake, a buzzer sounds as a warning, and **Release Parking Brake** appears on the driver information interface\*.

Always apply the parking brake when parking.

\* Not available on all models

## ■ Foot Brake

Your vehicle is equipped with disc brakes at the front, and drum brakes in the rear wheels. A vacuum power assist helps to reduce the effort needed on the brake pedal. The brake assist system increases the stopping force when you depress the brake pedal hard in an emergency situation. The anti-lock brake system (ABS) helps you retain steering control when braking very hard.

➤ **Brake Assist System** P. 238

➤ **Anti-lock Brake System (ABS)** P. 237

## ☒ Foot Brake

Check the brakes after driving through deep water, or if there is a buildup of road surface water. If necessary, dry the brakes by lightly depressing the pedal several times.

If you hear a continuous metallic friction sound when applying the brakes, the brake pads need to be replaced. Have the vehicle checked by a dealer.

Constantly using the brake pedal while going down a long hill builds up heat, which reduces the brake effectiveness. Apply engine braking by taking your foot off the accelerator pedal and downshifting to a speed position. With manual transmission use a lower gear for greater engine braking.

Do not rest your foot on the brake pedal while driving, as it will lightly apply the brakes and cause them to lose effectiveness over time and reduce pad life. It will also confuse drivers behind you.

## Anti-lock Brake System (ABS)

### ■ ABS

Helps to prevent the wheels from locking up, and helps you to retain steering control by pumping the brakes rapidly, much faster than you.

The electronic brake distribution (EBD) system, which is part of the ABS, also balances the front-to-rear braking distribution according to vehicle loading.

You should never pump the brake pedal. Let the ABS work for you by always keeping firm, steady pressure on the brake pedal. This is sometimes referred to as “stomp and steer.”

### ■ ABS operation

The brake pedal may pulsate slightly when the ABS is working. Depress the brake pedal and keep holding the pedal firmly down. On dry pavement, you will need to press on the brake pedal very hard before the ABS activates. However, you may feel the ABS activate immediately if you are trying to stop on snow or ice.

ABS may activate when you depress the brake pedal when driving on:

- Wet or snow covered roads.
- Roads paved with stone.
- Roads with uneven surfaces, such as potholes, cracks, manholes, etc.

When the vehicle speed goes under 10 km/h, the ABS stops.

\* Not available on all models

### ▶▶ Anti-lock Brake System (ABS)

#### NOTICE

The ABS may not function correctly if you use a tyre of the wrong size or type.

If the **ABS** indicator comes on while driving, there may be a problem with the system. While normal braking will not be affected, there is a possibility that the ABS will not be operating. Have your vehicle checked by a dealer immediately.

The ABS is not designed for the purpose of reducing the time or distance it takes for a vehicle to stop: It is designed to limit brake lockup which can lead to skidding and loss of steering control.

In the following cases, your vehicle may need more distance to stop than a vehicle without the ABS:

- You are driving on rough or uneven road surfaces, such as gravel or snow.
- The tyres are equipped with tyre chains\*.

The following may be observed with the ABS system:

- Motor sounds coming from the engine compartment when the brakes are applied, or when system checks are being performed after the engine has been started and while the vehicle accelerates.
- Brake pedal and/or the vehicle body vibration when ABS activates.

These vibrations and sounds are normal to ABS systems and are no cause for concern.

## Brake Assist System

---

Is designed to assist the driver by generating greater braking force when you depress the brake pedal hard during emergency braking.

### ■ Brake assist system operation

Press the brake pedal firmly for more powerful braking.

When brake assist operates, the pedal may wiggle slightly and an operating noise may be heard. This is normal. Keep holding the brake pedal firmly down.



## Emergency Stop Signal

Activates when you brake hard while driving at 60 km/h or above to alert drivers behind you about sudden braking by rapidly flashing hazard warning lights. This may help to alert drivers behind you to take appropriate means to avoid a possible collision with your vehicle.

### ■ When the system activates:

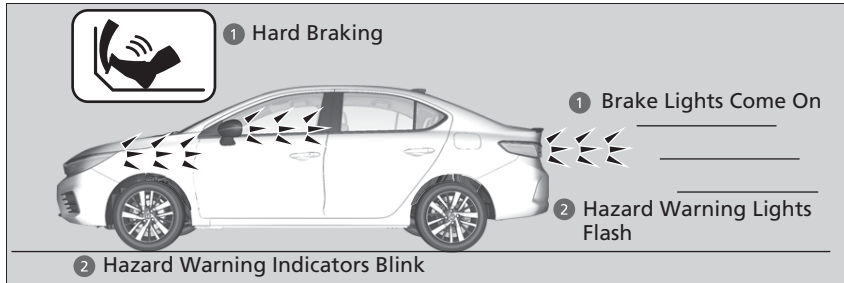

The hazard warning lights stop flashing when:

- The ABS is deactivated.
- Your vehicle's decelerating speed becomes moderate.
- You press the hazard warning button.

### ⌘ Emergency Stop Signal

The emergency stop signal is not a system that can prevent a possible rear-end collision caused by your hard braking. It flashes the hazard warning lights at the time you are braking hard. It is always recommended to avoid hard braking unless it is absolutely necessary.

The emergency stop signal does not activate with the hazard warning button pressed in.

If the ABS stops working for a certain period during braking, the emergency stop signal may not activate at all.

## When Stopped

1. Depress the brake pedal firmly.
2. Apply the parking brake.

### Continuously variable transmission models

3. Change the shift position to **P**.

### Manual transmission models

3. Move the shift lever to **1** or **R**.

### Diesel models

4. Keep idling the engine for about 10 seconds.

### All models

5. Turn off the engine.

Always set the parking brake firmly, in particular if you are parked on an incline.

### » Parking Your Vehicle

#### Continuously variable transmission models

## WARNING

The vehicle can roll away if left unattended without confirming that Park is engaged.

A vehicle that rolls away could cause a crash resulting in serious injury or death.

Always keep your foot on the brake pedal until you have confirmed that **P** is shown on the shift position indicator.

Do not park your vehicle near flammable objects, such as dry grass, oil, or timber. Heat from the exhaust can cause a fire.

#### Continuously variable transmission models

### NOTICE

The following can damage the transmission:

- Depressing the accelerator and brake pedals simultaneously.
- Holding the vehicle in place when facing uphill by depressing the accelerator pedal.
- Change the shift position to **P** before the vehicle stops completely.

## »» Parking Your Vehicle

**All models**

In extremely cold temperatures, the parking brake may freeze up if applied. If such temperatures are expected, do not apply the parking brake but, if parking on a slope, either turn the front wheels so they will contact the curb if the vehicle rolls down the slope or block the wheels to keep the vehicle from moving. If you do not take either precaution, the vehicle may roll unexpectedly, leading to a crash.

**Diesel models**

The engine idling may be prohibited in some countries. Check and follow your local legal requirements.

## Parking Sensor System \*

The rear corner\* and centre sensors monitor obstacles behind your vehicle, and the beeper and driver information interface\* lets you know the approximate distance between your vehicle and the obstacle.

### ■ The sensor location and range

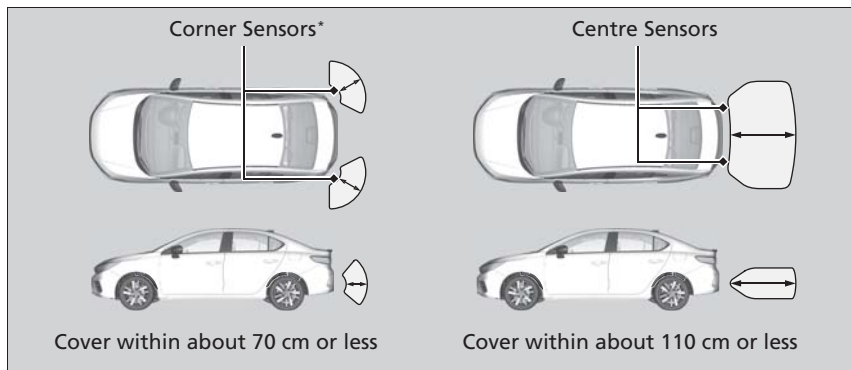

#### Models without parking sensor system button

The system activates when the transmission is in **R**, and the vehicle speed is less than 8 km/h.

#### ▶▶ Parking Sensor System \*

Even when the system is on, always confirm if there is no obstacle near your vehicle before parking.

The system may not work properly when:

- The sensors are covered with snow, ice, mud or dirt.
- The vehicle is on uneven surface, such as grass, bumps, or a hill.
- The vehicle has been out in hot or cold weather.
- The system is affected by devices that emit ultrasonic waves.
- Driving in bad weather.

The system may not sense:

- Thin or low objects.
- Sonic-absorptive materials, such as snow, cotton, or sponge.
- Objects directly under the bumper.

Do not put any accessories on or around the sensors.

#### Models with parking sensor system button

When you set the power mode to ON, the system will be in the previously selected condition.

Models with parking sensor system button

**Parking Sensor System On and Off**

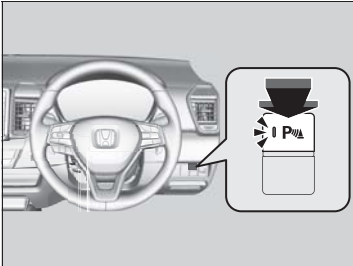

With the power mode in ON, press the parking sensor system button to turn on or off the system. The indicator in the button comes on when the system is on.

The rear centre and corner sensors start to detect an obstacle when the shift lever is in **R**, and the vehicle speed is less than 8 km/h.

**Manual transmission models**

You also need to release the parking brake.

### ■ When the Distance Between Your Vehicle and Obstacles Becomes Shorter

Length of the intermittent beep	Distance between the Bumper and Obstacle		Indicator* <sup>1</sup>	Driver information interface* <sup>1</sup>
	Corner Sensors*	Centre Sensors		
Moderate	—	About 60-110 cm	Blinks in Yellow* <sup>2</sup>	 <p>Approaching Object</p> <p>Indicators light where the sensor detects an obstacle</p>
Short	About 45-70 cm	About 45-60 cm	Blinks in Amber	
Very short	About 35-45 cm	About 35-45 cm		
Continuous	About 35 cm or less	About 35 cm or less	Blinks in Red	

\*1: Models with driver information interface

\*2: At this stage, only the centre sensors detect obstacles.

## Models with parking sensor system button

**Turning off All Rear Sensors**

1. Make sure that the parking sensor system is not activated. Set the power mode to VEHICLE OFF (LOCK).
2. Press and hold the parking sensor system button, and set the power mode to ON.
3. Keep pressing the button for 10 seconds. Release the button when the indicator in the button flashes.
4. Press the button again. The indicator in the button goes off.
  - ▶ The beeper sounds twice. The rear sensors are now turned off.

To turn the rear sensors on again, follow the above procedure. The beeper sounds three times when the rear sensors come back on.

## ☒ Turning off All Rear Sensors

When you set the shift position to **R**, the indicator in the parking sensor system button blinks as a reminder that the rear sensors have been turned off.

Petrol models

## Fuel Information

### ■ Fuel recommendation

Indonesian models

**Unleaded petrol, research octane number 90 or higher**

Use of lower octane petrol can cause a persistent, heavy metallic knocking noise that can lead to engine damage.

Except Indonesian models

**Unleaded petrol, research octane number 91 or higher**

Use of lower octane petrol can cause a persistent, heavy metallic knocking noise that can lead to engine damage.

### ■ Fuel tank capacity: 40 L

» Fuel Information

#### NOTICE

Use of petrol that contains lead presents the following risks:

- Damage to the exhaust system including the catalytic converter
- Damage to the engine and fuel system
- Detrimental effects on the engine and other systems



Diesel models

## Fuel Information

### ■ Fuel recommendation

#### Automotive Diesel Fuel

Use the automotive diesel fuel specified with a cetane number 51 or higher and up to 10 ppm of sulfur.

Select the proper fuel of clean and good quality according to the regional and climate condition. Use of improper fuel can reduce engine power.

### ■ Fuel tank capacity: 40 L

#### » Fuel Information

##### NOTICE

Serious damage may occur if petrol is used in diesel engines.

Your vehicle is not designed to use biodiesel. (pure or high concentration more than 7% vol) Consult a dealer for more information.

##### NOTICE

Not using the recommended automotive diesel fuel can cause the decreased engine performance.

Never use the heating oil and marine diesel fuel.

We recommend to replace the fuel filter before starting to drive if you have parked your vehicle for an extended period. The fuel filter may become clogged earlier than usual.

## How to Refuel

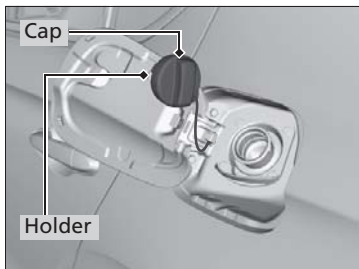
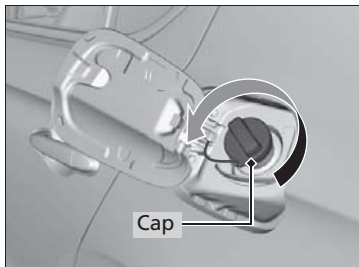
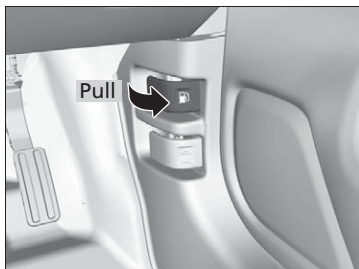

1. Stop your vehicle with the service station pump on the left side of the vehicle in the rear.
2. Turn off the engine.
3. Pull on the fuel fill door release handle under the driver's side lower outside corner of the dashboard.
  - ▶ The fuel fill door opens.
4. Remove the fuel fill cap slowly. If you hear a release of air, wait until this stops, then turn the knob slowly to open the fuel fill cap.
5. Place the fuel fill cap in the holder.
6. Insert the fuel filler nozzle fully.
  - ▶ When the tank is full, the filler nozzle will click off automatically. This leaves space in the fuel tank in case the fuel expands with a change in the temperature.
7. After filling, replace the fuel fill cap, tightening it until you hear it click at least once.
  - ▶ Shut the fuel fill door by hand.

### ▶▶ How to Refuel

## ⚠ WARNING

Fuel is highly flammable and explosive. You can be burned or seriously injured when handling fuel.

- Stop the engine, and keep heat, sparks, and flame away.
- Handle fuel only outdoors.
- Wipe up spills immediately.

The filler nozzle automatically stops to leave space in the fuel tank so that fuel does not overflow as a result of changes in air temperature.

Do not continue to add fuel after the filler nozzle has automatically stopped. Additional fuel can exceed the full tank capacity.

### Diesel models

Check if you have picked up the right nozzle. When you cannot insert the filler nozzle even though it is for diesel fuel, use the funnel provided with your vehicle.

## Improving Fuel Economy and Reducing CO<sub>2</sub> Emissions

Achieving fuel economy and reducing CO<sub>2</sub> emissions is dependent on several factors, including driving conditions, load weight, idling time, driving habits, and vehicle condition. Depending on these and other factors, you may not achieve the rated fuel economy of this vehicle.

### Maintenance and Fuel Economy

You can optimize your fuel economy with proper maintenance of your vehicle. Follow the maintenance schedule and, if necessary, consult your warranty booklet.

#### 📄 Maintenance Schedule P. 255

- Use engine oil with the viscosity recommended.
  - 📄 Recommended Engine Oil P. 266
- Maintain the specified tyre pressure.
- Do not load the vehicle with excess luggage.
- Keep your vehicle clean. A buildup of snow or mud on your vehicle's underside adds weight and increases wind resistance.

### 📄 Improving Fuel Economy and Reducing CO<sub>2</sub> Emissions

Direct calculation is the recommended method to determine actual fuel consumed while driving.

100	×	Litres of fuel	÷	Kilometres driven	=	L per 100 km
Kilometres driven	÷	Litres of fuel	=	Kilometres per Litre		



# Maintenance

This chapter discusses basic maintenance.



<b>Before Performing Maintenance</b>		
Inspection and Maintenance .....	252	
Safety When Performing Maintenance ....	253	
Parts and Fluids Used in Maintenance		
Service .....	254	
<b>Maintenance Schedule .....</b>	<b>255</b>	
<b>Maintenance Under the Bonnet</b>		
Maintenance Items Under the Bonnet ..	263	
Opening the Bonnet .....	265	
Recommended Engine Oil .....	266	
Oil Check .....	268	
Adding Engine Oil .....	270	
Engine Coolant .....	271	
	Transmission Fluid .....	274
	Brake/Clutch* Fluid .....	275
	Refilling Window Washer Fluid .....	276
	Fuel Filter .....	276
<b>Diesel Particulate Filter (DPF)</b>		
<b>Regeneration*</b> .....	277	
<b>Replacing Light Bulbs .....</b>	<b>280</b>	
<b>Checking and Maintaining Wiper</b>		
<b>Blades .....</b>	<b>294</b>	
<b>Checking and Maintaining Tyres</b>		
Checking Tyres .....	296	
Wear Indicators .....	298	
Tyre Service Life .....	298	
	Tyre and Wheel Replacement .....	299
	Tyre Rotation .....	300
	Snow Traction Devices .....	301
<b>Battery .....</b>	<b>303</b>	
<b>Remote Transmitter Care</b>		
Replacing the Button Battery .....	306	
<b>Cooling System*/Climate Control</b>		
<b>System* Maintenance .....</b>	<b>307</b>	
<b>Cleaning</b>		
Interior Care .....	309	
Exterior Care .....	311	
<b>Accessories and Modifications .....</b>	<b>314</b>	

\* Not available on all models

## Inspection and Maintenance

For your safety, perform all listed inspections and maintenance to keep your vehicle in good condition. If you become aware of any abnormality (noise, smell, insufficient brake fluid, oil residue on the ground, etc.), have your vehicle inspected by a dealer. Refer to the Service Book that came with your vehicle/maintenance schedule in this owner's manual for detailed maintenance and inspection information.

➤ **Maintenance Schedule** P. 255

### Types of Inspection and Maintenance

#### ■ Daily inspections

Perform inspections before long distance trips, when washing the vehicle, or when refueling.

#### ■ Periodic inspections

- Check the brake/clutch\* fluid level monthly.
  - **Brake/Clutch\* Fluid** P. 275
- Check the tyre pressure monthly. Examine the tread for wear and foreign objects.
  - **Checking and Maintaining Tyres** P. 296
- Check the operation of the exterior lights monthly.
  - **Replacing Light Bulbs** P. 280
- Check the condition of the wiper blades at least every six months.
  - **Checking and Maintaining Wiper Blades** P. 294

## Safety When Performing Maintenance

Some of the most important safety precautions are given here. However, we cannot warn you of every conceivable hazard that can arise in performing maintenance. Only you can decide whether you should perform a given task.

### Maintenance Safety

- To reduce the possibility of fire or explosion, keep cigarettes, sparks, and flames away from the battery and all fuel related parts.
- Never leave rags, towels, or other flammable objects under the bonnet.
  - ▶ Heat from the engine and exhaust can ignite them, causing a fire.
- To clean parts, use a commercially available degreaser or parts cleaner, not petrol.
- Wear eye protection and protective clothing when working with the battery or compressed air.
- Engine exhaust contains carbon monoxide, which is poisonous and can kill you.
  - ▶ Only operate the engine if there is sufficient ventilation.

### Vehicle Safety

- The vehicle must be in a stationary condition.
  - ▶ Make sure your vehicle is parked on level ground, the parking brake is set, and the engine is off.
- Be aware that hot parts can burn you.
  - ▶ Make sure to let the engine and exhaust system cool thoroughly before touching vehicle parts.
- Be aware that moving parts can injure you.
  - ▶ Do not start the engine unless instructed, and keep your hands and limbs away from moving parts.

#### ⚠ Safety When Performing Maintenance

### ⚠ WARNING

Improperly maintaining this vehicle or failing to correct a problem before driving can cause a crash in which you can be seriously hurt or killed.

Always follow the inspection and maintenance recommendations and schedules in this owner's manual/Service Book.

### ⚠ WARNING

Failure to properly follow maintenance instructions and precautions can cause you to be seriously hurt or killed.

Always follow the procedures and precautions in this owner's manual.

## Parts and Fluids Used in Maintenance Service

---

The use of Honda genuine parts and fluids is recommended when maintaining and servicing your vehicle. Honda genuine parts are manufactured according to the same high quality standards used in Honda vehicles.

### ▶ Parts and Fluids Used in Maintenance Service

#### Diesel models

#### NOTICE

Do not press the engine cover forcibly. This may damage the engine cover and component parts.



# Maintenance Schedule

If your vehicle comes with the Service Book (**Warranty Booklet**), the maintenance schedule for your vehicle is available in the book. For vehicles without the Service Book (**Warranty Booklet**), refer to the following maintenance schedule.

The maintenance schedule outlines the minimum required maintenance that you should perform to ensure the troublefree operation of your vehicle. Due to regional and climatic differences, some additional servicing may be required. Please consult your warranty booklet for a more detailed description.

Maintenance work should be performed by properly trained and equipped technicians. Your authorised dealer meets all of these requirements.

Petrol models

Except South African models

Service at the indicated distance or time - whichever comes first.	km x 1,000	20	40	60	80	100	120	140	160	180	200
	months	12	24	36	48	60	72	84	96	108	120
Replace engine oil	Normal	Every 10,000 km or 1 year									
	Severe* <sup>2</sup>	Every 5,000 km or 6 months									
Replace engine oil filter	Normal	Every 20,000 km or 2 years									
	Severe* <sup>2</sup>	Every 10,000 km or 1 year									
Replace air cleaner element		Every 30,000 km* <sup>3</sup> , * <sup>4</sup> Every 20,000 km* <sup>5</sup>									
Inspect valve clearance* <sup>1</sup>		Every 120,000 km									

\*1: Sensory Method: Adjust the valves during service 120,000 km if they are noisy.

\*2: Refer to page 258 for replacement information under severe conditions.

\*3: Bhutanese, Nepalese, Sri Lankan and Malaysian models

\*4: African models

\*5: Indian models

Service at the indicated distance or time - whichever comes first.	km x 1,000	20	40	60	80	100	120	140	160	180	200
	months	12	24	36	48	60	72	84	96	108	120
Replace spark plugs		Every 100,000 km									
Inspect drive belt			•		•		•		•		•
Replace engine coolant		At 200,000 km or 10 years, thereafter every 100,000 km or 5 years									
Replace transmission fluid	MT Normal						•				
	Severe*2			•			•			•	
	CVT		•		•		•		•		•
Replace dust and pollen filter		•	•	•	•	•	•	•	•	•	•
Inspect front and rear brakes		Every 10,000 km or 1 year									
Replace fuel filter*1	Normal	Every 140,000 km*3 Every 120,000 km*4, *5									
	Severe*2	Every 90,000 km*3 Every 60,000 km*4, *5									
Replace brake fluid		Every 3 years									
Check parking brake adjustment		•	•		•		•		•		•
Rotate tyres (Check tyre inflation and condition at least once per month)		Every 10,000 km									

\*1: It is recommended that you replace the fuel filter if the fuel you are using is suspected to be contaminated with dust, etc. because the filter may be clogged sooner.

\*2: Refer to page 258 for replacement information under severe conditions.

\*3: Bhutanese, Nepalese, Sri Lankan and Malaysian models

\*4: Indian models

\*5: African models

Service at the indicated distance or time - whichever comes first.	km x 1,000	20	40	60	80	100	120	140	160	180	200
	months	12	24	36	48	60	72	84	96	108	120

**Visually inspect the following items:**

Tie rod ends, steering gear box, and boots	Every 10,000 km or 1 year										
Suspension components											
Driveshaft boots											
Brake hoses and lines (including ABS/VSA)	•	•	•	•	•	•	•	•	•	•	•
All fluid levels and condition of fluid											
Exhaust system											
Fuel lines and connections											

If you drive your vehicle under severe conditions, you must have the following items served to the maintenance schedule indicated as Severe.

Items	Condition
Engine oil and oil filter	A, B, C, D and E
Transmission fluid	B, D

» Maintenance Schedule

The condition is considered as severe when you drive:

- A. less than 8 km, or less than 16 km in freezing temperatures per trip.
- B. In extremely hot temperature above 35°C.
- C. With extensive idling or long periods of stop-and-go.
- D. With a loaded roof rack, or in mountains.
- E. On muddy, dusty or de-iced roads.

**Diesel models**

Service at the indicated distance or time - whichever comes first.	km x 1,000	20	40	60	80	100	120	140	160	180	200
	months	12	24	36	48	60	72	84	96	108	120
Replace engine oil	Normal	Every 10,000 km or 1 year									
	Severe* <sup>1</sup>	Every 5,000 km or 6 months									
Replace engine oil filter	Normal	Every 10,000 km or 1 year									
	Severe* <sup>1</sup>	Every 5,000 km or 6 months									
LAF (A/F) sensor cleaning		Every 10,000 km or 1 year									
Replace air cleaner element	Dry	Every 20,000 km* <sup>2</sup>									
		Every 30,000 km* <sup>3</sup>									
Replace fuel filter		Every 20,000 km* <sup>2</sup>									
		Every 30,000 km* <sup>3</sup>									
Inspect drive belts			•		•		•		•		•
Replace engine coolant						•			•		
Replace transmission fluid	MT Normal						•				
	Severe* <sup>1</sup>			•			•			•	

\*1: Refer to page 261 for replacement information under severe conditions.

\*2: Indian models

\*3: Bhutanese and Nepalese models

Service at the indicated distance or time - whichever comes first.	km x 1,000	20	40	60	80	100	120	140	160	180	200
	months	12	24	36	48	60	72	84	96	108	120
Replace dust and pollen filter		•	•	•	•	•	•	•	•	•	•
Inspect front and rear brakes		Every 10,000 km or 1 year									
Replace brake fluid		Every 3 years									
Check parking brake adjustment		•	•		•		•		•		•
Rotate tyres (Check tyre inflation and condition at least once per month)		Every 10,000 km									

**Visually inspect the following items:**

Tie rod ends, steering gear box, and boots	Every 10,000 km or 1 year										
Suspension components	Every 10,000 km or 1 year										
Driveshaft boots	Every 10,000 km or 1 year										
Brake hoses and lines (including ABS/VA)		•	•	•	•	•	•	•	•	•	•
All fluid levels and condition of fluid		•	•	•	•	•	•	•	•	•	•
Exhaust system		•	•	•	•	•	•	•	•	•	•
Fuel lines and connections		•	•	•	•	•	•	•	•	•	•

If you drive your vehicle under severe conditions, you must have the following items served to the maintenance schedule indicated as Severe.

Items	Condition
Engine oil and oil filter	A, B, C, D and E
Transmission fluid	B, D

⌘ Maintenance Schedule

The condition is considered as severe when you drive:

- A. less than 8 km, or less than 16 km in freezing temperatures per trip.
- B. In extremely hot temperature above 35°C.
- C. With extensive idling or long periods of stop-and-go.
- D. With a loaded roof rack, or in mountains.
- E. On muddy, dusty or de-iced roads.

## Maintenance Record (On Vehicles without Service Book)

Have your servicing dealer record all required maintenance below. Keep receipts for all work done on your vehicle.

Km or Month	Date	Sign or Stamp
<b>20,000 km</b> (or 12 Mo.)		
<b>40,000 km</b> (or 24 Mo.)		
<b>60,000 km</b> (or 36 Mo.)		
<b>80,000 km</b> (or 48 Mo.)		
<b>100,000 km</b> (or 60 Mo.)		
<b>120,000 km</b> (or 72 Mo.)		
<b>140,000 km</b> (or 84 Mo.)		
<b>160,000 km</b> (or 96 Mo.)		
<b>180,000 km</b> (or 108 Mo.)		
<b>200,000 km</b> (or 120 Mo.)		



## Maintenance Items Under the Bonnet

Petrol models

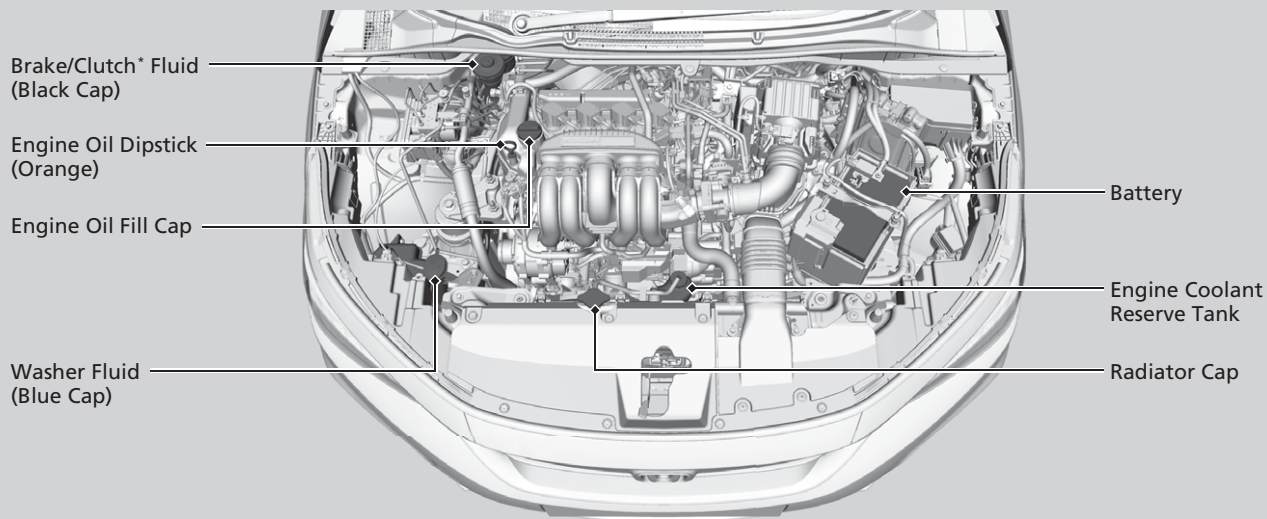

\* Not available on all models

Diesel models

Brake/Clutch Fluid  
(Black Cap)

Engine Oil Fill Cap

Engine Oil Dipstick  
(Orange)

Washer Fluid  
(Blue Cap)

Engine Coolant  
Reserve Tank

Battery

Radiator Cap

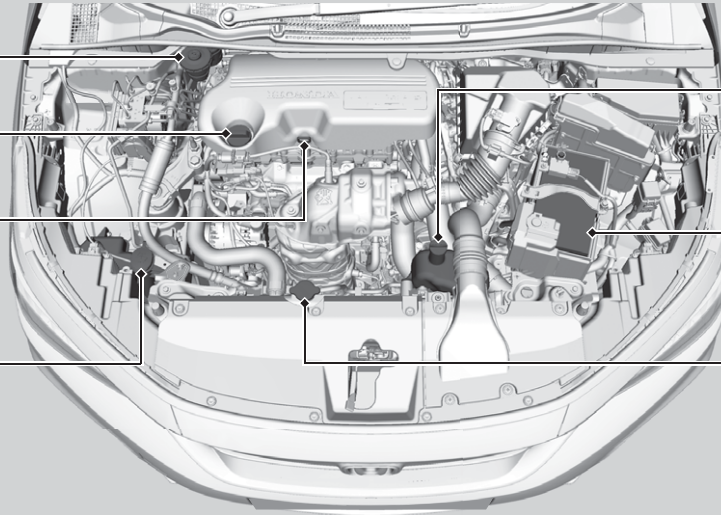

## Opening the Bonnet

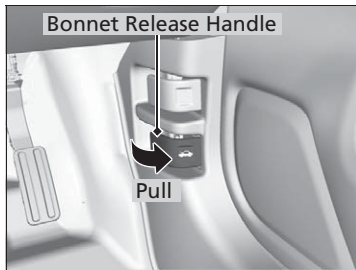

1. Park the vehicle on a level surface, and set the parking brake.
2. Pull the bonnet release handle under the driver's side lower outside corner of the dashboard.
  - ▶ The bonnet will pop up slightly.

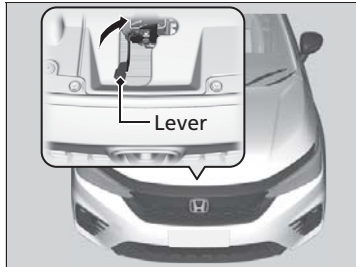

3. Pull up the bonnet latch lever (located under the front edge of the bonnet to the centre) and raise the bonnet. Once you have raised the bonnet slightly, you can release the lever.

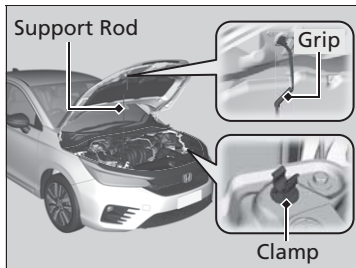

4. Remove the support rod from the clamp using the grip. Mount the support rod in the bonnet.

When closing, remove the support rod, and stow it in the clamp, then gently lower the bonnet. Remove your hand at a height of approximately 30 cm and let the bonnet close.

### Opening the Bonnet

#### NOTICE

Do not open the bonnet when the wiper arms are raised. The bonnet will strike the wipers, resulting in possible damage to the bonnet and/or the wipers.

#### Diesel models

#### NOTICE

Do not press the engine cover forcibly. This may damage the engine cover and component parts.

When closing the bonnet, check that the bonnet is securely latched.

If the bonnet latch lever moves stiffly, or if you can open the bonnet without lifting the lever, the latch mechanism should be cleaned and lubricated.

Petrol models

## Recommended Engine Oil

Use a genuine engine oil or another commercial engine oil of suitable type and viscosity (for the ambient temperature) as shown in the image that follows.

Oil is a major contributor to your engine's performance and longevity. If you drive the vehicle with insufficient or deteriorated oil, the engine may fail or be damaged.

Genuine Engine Oil	Commercial Engine Oil
<ul style="list-style-type: none"> <li>• Honda Engine OIL #1.0</li> <li>• Honda Green OIL</li> <li>• Honda Genuine Motor Oil</li> </ul>	<ul style="list-style-type: none"> <li>• API service SM or higher grade fuel-efficient oil</li> <li>• ACEA A5/B5</li> </ul>

\*1: Formulated to improve fuel economy.

### Recommended Engine Oil

#### Engine Oil Additives

Your vehicle does not require oil additives. In fact, they may adversely affect the engine performance and durability.

Diesel models

## Recommended Engine Oil

Use a genuine engine oil or another commercial engine oil of suitable type and viscosity (for the ambient temperature) as shown in the image that follows.

Oil is a major contributor to your engine's performance and longevity. If you drive the vehicle with insufficient or deteriorated oil, the engine may fail or be damaged.

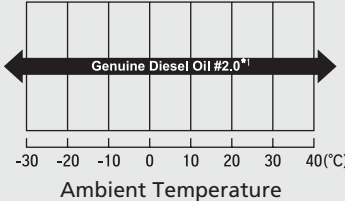
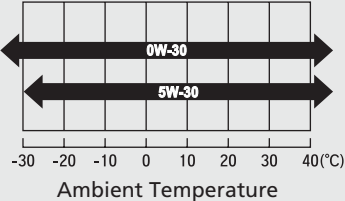
Genuine Engine Oil	Commercial Engine Oil
<ul style="list-style-type: none"> <li>• Honda Genuine Diesel Oil #2.0</li> </ul>	<ul style="list-style-type: none"> <li>• ACEA C2/C3</li> </ul>
 <p>A horizontal bar chart showing the ambient temperature range for Genuine Diesel Oil #2.0. The x-axis is labeled 'Ambient Temperature' and ranges from -30 to 40°C with major ticks every 10 units. A single double-headed arrow spans the entire range from -30 to 40°C, with the text 'Genuine Diesel Oil #2.0*1' centered above it.</p>	 <p>A horizontal bar chart showing the ambient temperature ranges for commercial engine oils. The x-axis is labeled 'Ambient Temperature' and ranges from -30 to 40°C with major ticks every 10 units. Two double-headed arrows are shown: the top one is labeled '0W-30' and spans from -30 to 40°C; the bottom one is labeled '5W-30' and spans from -20 to 40°C.</p>

\*1: Formulated to improve fuel economy.

### Recommended Engine Oil

#### Engine Oil Additives

Your vehicle does not require oil additives. In fact, they may adversely affect the engine performance and durability.

## Oil Check

We recommend that you check the engine oil level every time you refuel.

Park the vehicle on level ground.

Wait approximately three minutes after turning the engine off before you check the oil.

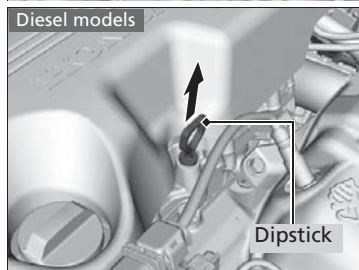
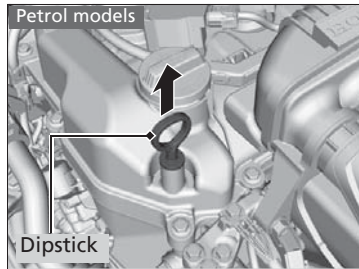

1. Remove the dipstick (orange).
2. Wipe the dipstick with a clean cloth or paper towel.
3. Insert the dipstick back all the way into its hole.

### Oil Check

If the oil level is near or below the lower mark, slowly add oil, being careful not to overfill.

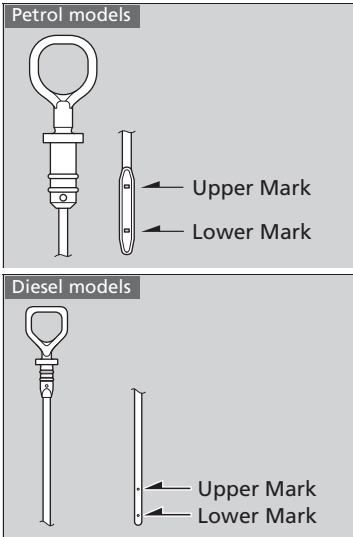

4. Remove the dipstick again, and check the level. It should be between the upper and lower marks. Add oil if necessary.

## Adding Engine Oil

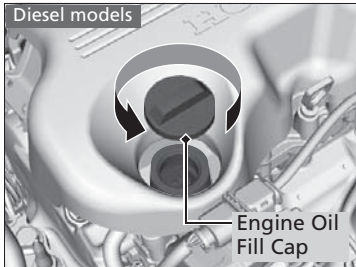
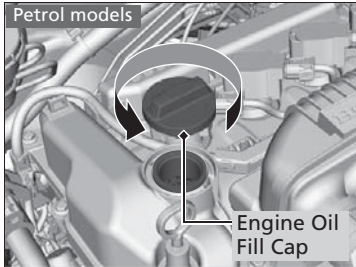

1. Unscrew and remove the engine oil fill cap.
2. Add oil slowly.
3. Reinstall the engine oil fill cap, and tighten it securely.
4. Wait for three minutes and recheck the engine oil dipstick.

### ►► Adding Engine Oil

#### NOTICE

Do not fill the engine oil above the upper mark. Overfilling the engine oil may result in leaks and engine damage.

If any oil spills, wipe it away immediately. Spilled oil may damage the engine compartment components.



## Engine Coolant

### Specified coolant: Honda All Season Antifreeze/Coolant Type 2

This coolant is premixed with 50% antifreeze and 50% water. Do not add any straight antifreeze or water.

We recommend you check the engine coolant level every time you refuel. Check the reserve tank first. If it is completely empty, also check the coolant level in the radiator. Add the engine coolant accordingly.

### Reserve Tank

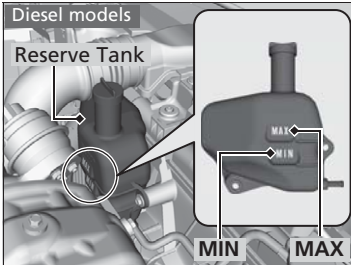
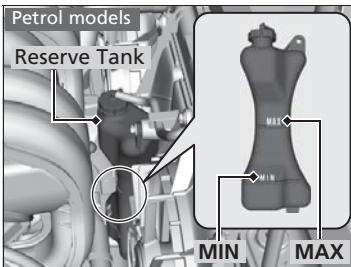

1. Make sure the engine and radiator are cool.
2. Check the amount of coolant in the reserve tank.
  - ▶ If the coolant level is below the **MIN** mark, add the specified coolant until it reaches the **MAX** mark.
3. Inspect the cooling system for leaks.

### Engine Coolant

## ⚠ WARNING

Removing the radiator cap while the engine is hot can cause the coolant to spray out, seriously scalding you.

Always let the engine and radiator cool down before removing the radiator cap.

If temperatures consistently below  $-30^{\circ}\text{C}$  are expected, the coolant mixture should be changed to a higher concentration. Consult your Honda dealer for details about a suitable coolant mixture.

If Honda antifreeze/coolant is not available, you may use another major brand of non-silicate coolant as a temporary replacement. Check that it is a high quality coolant recommended for aluminium engines. Continued use of any non-Honda coolant can result in corrosion, causing the cooling system to malfunction or fail. Have the cooling system flushed and refilled with Honda antifreeze/coolant as soon as possible.

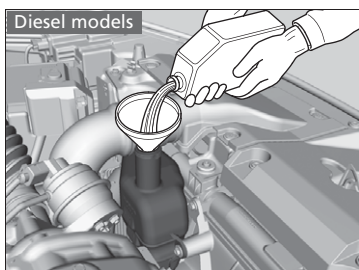
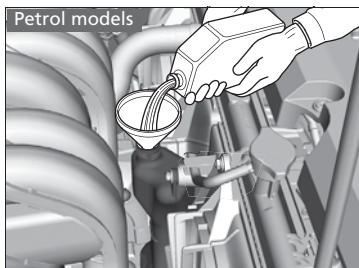

►► Engine Coolant

Do not add rust inhibitors or other additives to your vehicle's cooling system. They may not be compatible with the coolant or with the engine components.

## Radiator

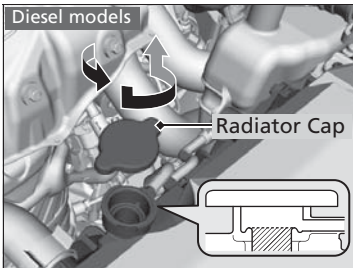
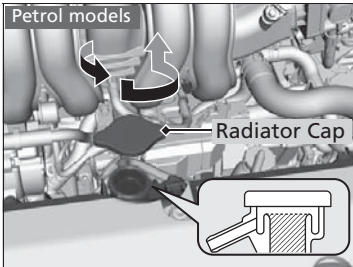

1. **Make sure the engine and radiator are cool.**
2. Turn the radiator cap 1/8 turn anticlockwise and relieve any pressure in the cooling system.
3. Push down and turn the radiator cap anticlockwise to remove it.
4. The coolant level should be up to the base of the filler neck. Add coolant if it is low.
5. Put the radiator cap back on, and tighten it fully.

### ►► Radiator

#### NOTICE

Pour the fluid slowly and carefully so you do not spill any. Clean up any spills immediately; they can damage components in the engine compartment.

## Transmission Fluid

### Manual transmission models

#### Manual Transmission Fluid

##### Specified fluid: Honda MTF

Have a dealer check the fluid level and replace if necessary. Follow your vehicle's maintenance service timing of when to change manual transmission fluid.

➤ **Maintenance Schedule** P. 255

Do not attempt to check or change the manual transmission fluid yourself.

### Continuously variable transmission models

#### Continuously Variable Transmission (CVT) Fluid

##### Specified fluid: Honda HCF-2

Have a dealer check the fluid level and replace if necessary. Follow your vehicle's maintenance service timing of when to change continuously variable transmission fluid.

➤ **Maintenance Schedule** P. 255

Do not attempt to check or change the continuously variable transmission fluid yourself.

### Manual Transmission Fluid

#### NOTICE

If Honda MTF is not available, you may use the API certificated SAE 0W-20 or 5W-20 viscosity motor oil as a temporary measure.

Replace with MTF as soon as possible. Motor oil does not contain the proper additives for the transmission and continued use can cause decreased shifting performance and lead to transmission damage.

### Continuously Variable Transmission (CVT) Fluid

#### NOTICE

**Do not mix Honda HCF-2 with other transmission fluids.**

Using a transmission fluid other than Honda HCF-2 may adversely affect the operation and durability of your vehicle's transmission, and damage the transmission.

Any damage caused by using a transmission fluid that is not equivalent to Honda HCF-2 is not covered by Honda's new vehicle limited warranty.

## Brake/Clutch\* Fluid

**Specified fluid: Brake Fluid with DOT 3 or DOT 4**

### Checking the Brake Fluid

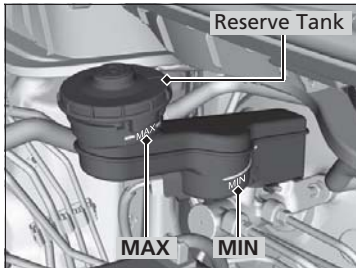

The fluid level should be between the **MIN** and **MAX** marks on the side of the reserve tank.

#### Manual transmission models

The brake fluid reserve tank is also used for your vehicle's clutch fluid. As long as you keep the brake fluid level as instructed above, there is no need for checking the clutch fluid level.

#### » Brake/Clutch\* Fluid

##### NOTICE

Brake fluid marked DOT 5 is not compatible with your vehicle's braking system and can cause extensive damage.

We recommend using a genuine product.

If the brake fluid level is at or below the **MIN** mark, have a dealer inspect the vehicle for leaks or worn brake pads as soon as possible.

\* Not available on all models

## Refilling Window Washer Fluid

Check the amount of window washer fluid by looking at the reservoir.

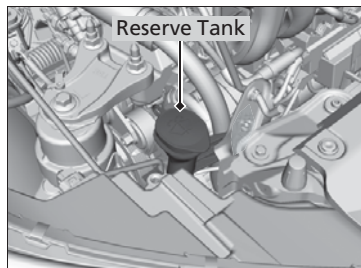

If the level is low, fill the washer reservoir.

Pour the washer fluid carefully. Do not overflow the reservoir.

### ► Refilling Window Washer Fluid

#### NOTICE

Do not use engine antifreeze or a vinegar/water solution in the windscreen washer reservoir. Antifreeze can damage your vehicle's paint. A vinegar/water solution can damage the windscreen washer pump. Use only commercially available windscreen washer fluid. Avoid prolonged use of hard water to prevent lime scale build up.

## Fuel Filter

Replace fuel filter according to the time and distance recommendations in the maintenance schedule.

Have a qualified technician change the fuel filter. Fuel in the system can spray out and create a hazard if all fuel line connections are not handled correctly.

### Diesel Particulate Filter (DPF)

Collects particulate matter (PM) from the exhaust gas. The DPF is installed in the catalytic converter.

#### How the DPF Works

The DPF periodically burns off the collected PM while driving at a high temperature of catalytic converter.

When PM is burned off, you may notice white smoke in the exhaust gas, and the increase in the average fuel consumption. This is temporary, and normal.

#### ⓘ Diesel Particulate Filter (DPF)

The DPF must operate at a high temperature for the chemical reactions to take place. It can set on fire any combustible materials that come near it. Park your vehicle away from high grass, dry leaves, or other flammables.

\* Not available on all models

Models with driver information interface

## Regenerating DPF



DPF regeneration  
Required

Regenerate the DPF when this symbol appears.



Diesel Particulate  
Filter Full.  
Power May Be  
Reduced.

Take your vehicle to a dealer when this warning symbol appears.

If you see  on the driver information interface, you need to regenerate the DPF:

- Drive your vehicle at a speed of 20 km/h or over until the symbol disappears.
  - ▶ It takes about 30 minutes to increase the catalytic converter temperature to burn out and remove PM.

## Regenerating DPF

### NOTICE

If you ignore the symbol and do not regenerate the DPF, the driver information interface changes to the DPF warning symbol. If this happens, take your vehicle to a dealer as soon as possible. Engine oil is required to be checked and replaced, if necessary. Continuously ignoring the driver information interface warning symbol causes the DPF to be clogged with PM, seriously damaging the DPF and emission control systems, which may need replacement.

To minimise the accumulation of PM, always use the recommended diesel fuel.

 **Fuel Information** P. 247

PM is accumulated in the catalytic converter when you drive at a low speed for a long period of time or by frequent short journeys.



Models with information display

## Regenerating DPF

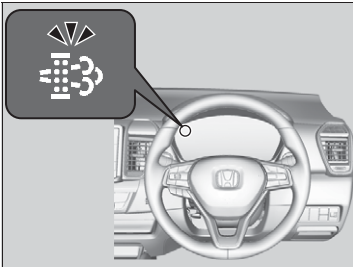

If the Diesel Particulate Filter (DPF) indicator blinks, you need to regenerate the DPF:

- Drive your vehicle at a speed of 20 km/h or over until the indicator goes off.
  - ▶ It takes about 30 minutes to increase the catalytic converter temperature to burn out and remove PM.

## ▶▶ Regenerating DPF

### NOTICE

If you ignore the DPF indicator blinking and do not regenerate the DPF, the indicator comes on. If this happens, take your vehicle to a dealer as soon as possible. Engine oil is required to be checked and replaced, if necessary. Continuously ignoring the indicator coming on causes the DPF to be clogged with PM, seriously damaging the DPF and emission control systems, which may need replacement.

To minimise the accumulation of PM, always use the recommended diesel fuel.

▶ **Fuel Information** P. 247

PM is accumulated in the catalytic converter when you drive at a low speed for a long period of time or by frequent short journeys.

## Headlight Bulbs

When replacing, use the following bulbs.

- |                             |  |
|-----------------------------|--|
| <b>High beam headlight:</b> | <b>60 W (HB3 for halogen bulb type)*</b><br><b>LED type*</b> |
| <b>Low beam headlight:</b>  | <b>55 W (H7 for halogen bulb type)*</b><br><b>LED type*</b>  |

### High Beam Headlights

#### Models with halogen headlights

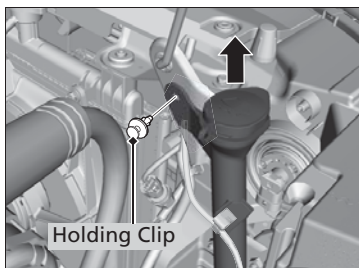

#### Driver side

1. Remove the holding clip using a flat-tip screwdriver, then remove the upper part of the window washer reserve tank.

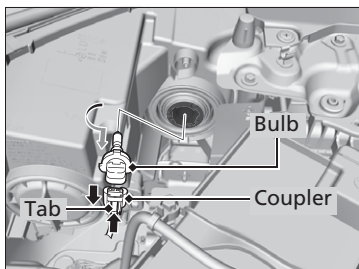

#### Both sides

2. Push the tab to remove the coupler.
3. Rotate the old bulb anticlockwise to remove.
4. Insert a new bulb into the headlight assembly and turn it clockwise.
5. Insert the coupler into the connector of the bulb.

#### Headlight Bulbs

##### NOTICE

Halogen bulbs get very hot when lit. Oil, perspiration, or a scratch on the glass can cause the bulb to overheat and shatter.

The headlight aim is set by the factory, and does not need to be adjusted. However, if you regularly carry heavy items in the boot, have the aiming readjusted at a dealer or by a qualified technician.

When replacing a halogen bulb, handle it by its base, and protect the glass from contact with your skin or hard objects. If you touch the glass, clean it with denatured alcohol and a clean cloth.

#### Models with LED headlights

High beam and low beam headlights are LED type. Have an authorised Honda dealer inspect and replace the light assembly.

#### Holding clip

Insert a flat-tip screwdriver, lift and remove the centre pin to remove the clip.

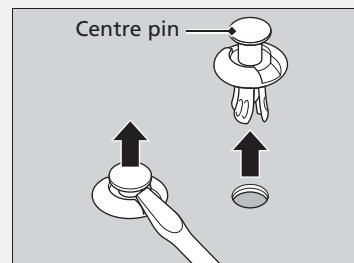

## Low Beam Headlights

Models with halogen headlights

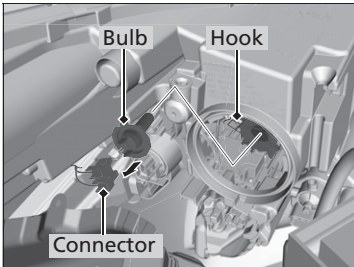
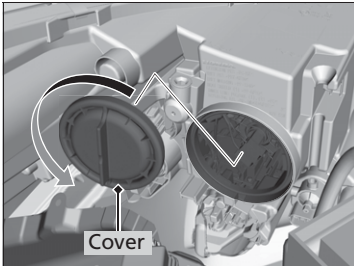

1. Rotate the cover anticlockwise to remove.
2. Unhook the hook, and pull out the connector.
3. Remove the old bulb and insert the new bulb.
4. Put the connector back into the bulb.

### Headlight Bulbs

Insert the clip with the centre pin raised, and push until it is flat.

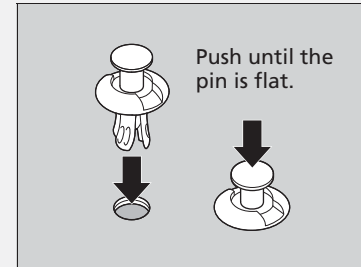

## Front Turn Signal Light Bulbs

When replacing, use the following bulbs.

**Front Turn Signal Light: 21 W (Amber)\*  
LED type\***

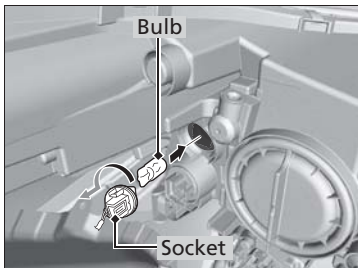

1. Turn the socket anticlockwise and remove it.
2. Remove the old bulb and insert a new bulb.

## Position/Daytime Running Lights

Position/daytime running lights are LED type. Have an authorised Honda dealer inspect and replace the light assembly.

### ►► Front Turn Signal Light Bulbs

#### Models with LED front turn signal lights

Front turn signal lights are LED type. Have an authorised Honda dealer inspect and replace the light assembly.

## Fog Light Bulbs\*

When replacing, use the following bulbs.

**Fog Light: 19 W (H16 for halogen bulb type)\***  
**35 W (H8 for halogen bulb type)\***  
**LED type\***

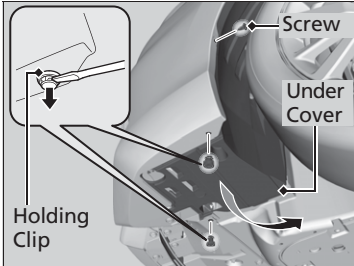

1. Remove the screw using a Phillips-head screwdriver and remove the holding clips using a flat-tip screwdriver.
2. Pull down the under cover.

### ⌘ Fog Light Bulbs\*

#### NOTICE

Halogen bulbs get very hot when lit. Oil, perspiration, or a scratch on the glass can cause the bulb to overheat and shatter.

When replacing a halogen bulb, handle it by its plastic case, and protect the glass from contact with your skin or hard objects. If you touch the glass, clean it with denatured alcohol and a clean cloth.

#### Models with LED fog lights

Front fog lights are LED type. Have an authorised Honda dealer inspect and replace the light assembly.

#### Holding clip

Insert a flat-tip screwdriver, lift and remove the centre pin to remove the clip.

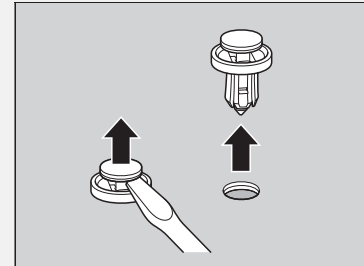

\* Not available on all models

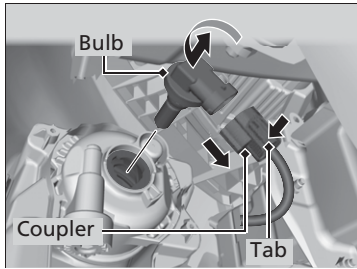

3. Push the tab to remove the coupler.
4. Rotate the old bulb to the left to remove.
5. Insert a new bulb into the fog light assembly and turn it to the right.
6. Insert the coupler into the connector of the bulb.

► Fog Light Bulbs\*

Insert the clip with the centre pin raised, and push until it is flat.

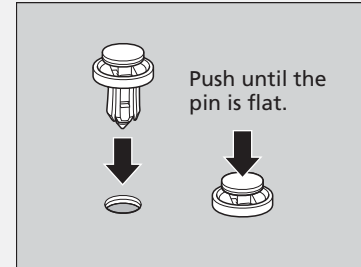

## Side Turn Signal/Emergency Indicator Light Bulbs

### Fender type

When replacing, use the following bulbs.

### Side Turn Signal Light: 5 W (Amber)

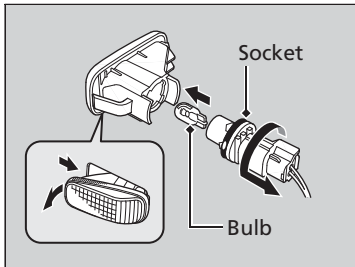

1. Push the front of the side turn signal assembly towards the rear of the vehicle until it pops out of the body.
2. Turn the socket anticlockwise and remove it.
3. Remove the old bulb and insert a new bulb.

### Door mirror type

Door mirror side turn lights are LED type. Have an authorised Honda dealer inspect and replace the light assembly.

## Brake/Taillight, Rear Side Marker Light and Rear Turn Signal Light Bulbs

When replacing, use the following bulbs.

<b>Brake/Taillight:</b>	<b>LED Type</b>
<b>Rear Side Marker Light:</b>	<b>LED Type</b>
<b>Rear Turn Signal Light:</b>	<b>21W (Amber)</b>

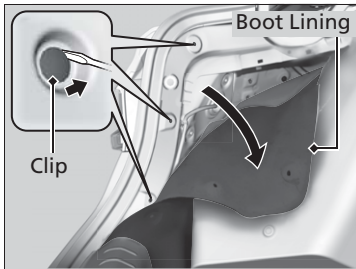

1. Remove the holding clips using a flat-tip screwdriver, then pull the lining back.

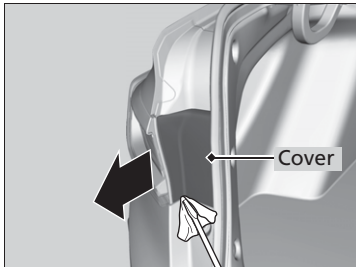

2. Pry on the edge of the cover using a flat-tip screwdriver to remove the cover.
  - Wrap the flat-tip screwdriver with a cloth to prevent scratches.

### ⚠ Brake/Taillight, Rear Side Marker Light and Rear Turn Signal Light Bulbs

Brake/taillights, rear side marker lights are LED type. Have an authorised Honda dealer inspect and replace the light assembly.



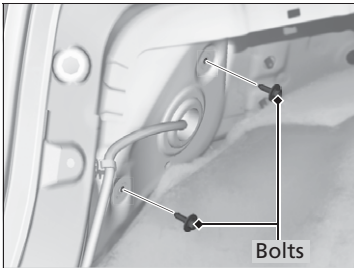

3. Use a Phillips-head screwdriver or socket to remove the bolts.

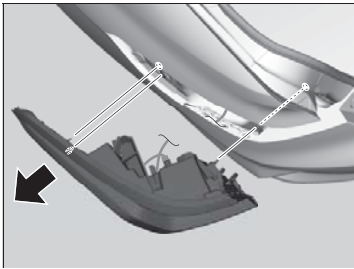

4. Pull the light assembly out of the rear pillar.

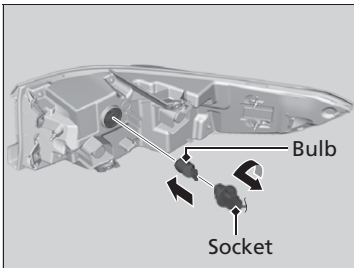

5. Turn the socket anticlockwise and remove it.

6. Remove the old bulb and insert a new bulb.

## Back-Up Light and Taillight Bulbs

When replacing, use the following bulbs.

<b>Back-Up Light:</b>	<b>16 W</b>
<b>Taillight:</b>	<b>LED Type</b>

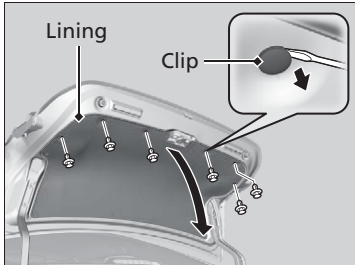

1. Remove the holding clips using a flat-tip screwdriver, then pull the lining back.

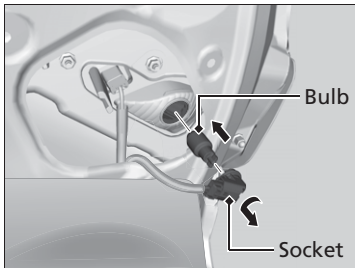

2. Turn the socket anticlockwise and remove it.
3. Remove the old bulb and insert a new bulb.

### ▶▶ Back-Up Light and Taillight Bulbs

Taillights are LED type. Have an authorised Honda dealer inspect and replace the light assembly.

## Rear Licence Plate Light Bulbs

When replacing, use the following bulb.

**Rear Licence Plate Light: 5 W**

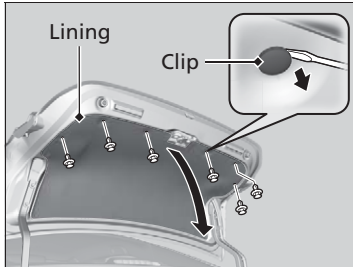

1. Remove the holding clips using a flat-tip screwdriver, then pull the lining back.

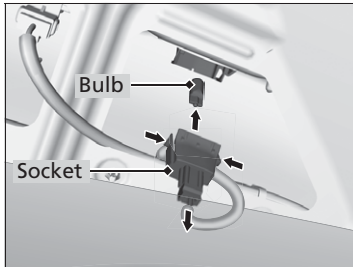

2. Remove the licence plate light assembly by squeezing the tabs on both sides of the socket.
3. Remove the old bulb and insert a new bulb.

## High-Mount Brake Light

---

High-mount brake light is LED type. Have an authorised Honda dealer inspect and replace the light assembly.

## Other Light Bulbs

### ■ Ceiling Light Bulb\*

When replacing, use the following bulb.

**Ceiling Light: 8 W**

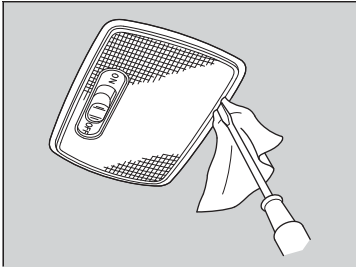

1. Pry on the edge of the cover using a flat-tip screwdriver to remove the cover.
  - ▶ Wrap the flat-tip screwdriver with a cloth to prevent scratches.

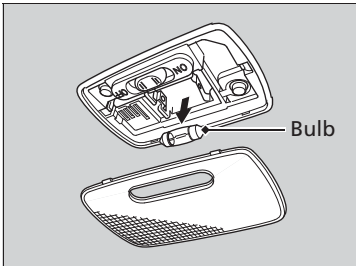

2. Remove the old bulb and insert a new bulb.

\* Not available on all models

### ■ Ceiling Light Bulb\*

When replacing, use the following bulb.

**Ceiling Light: 8 W**

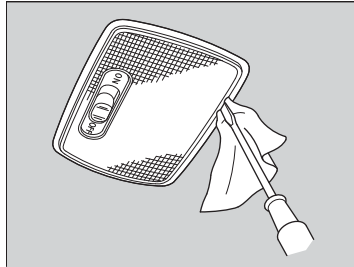

1. Pry on the edge of the cover using a flat-tip screwdriver to remove the cover.
  - ▶ Wrap the flat-tip screwdriver with a cloth to prevent scratches.

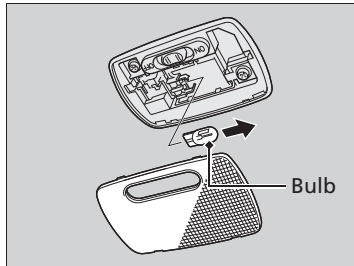

2. Remove the old bulb and insert a new bulb.

### Models with sunroof

### ■ Map Light Bulbs\*

When replacing, use the following bulbs.

**Map Light: 8 W**

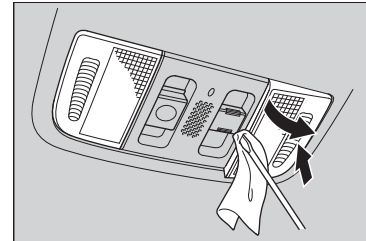

1. Push on the lens of the opposite side you are replacing.
2. Pry on the edge of the cover using a flat-tip screwdriver to remove the cover.
  - ▶ Wrap the flat-tip screwdriver with a cloth to prevent scratches.

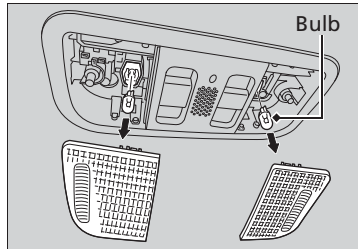

3. Remove the old bulb and insert a new bulb.

**Models without sunroof**

**Map Light Bulbs \***

When replacing, use the following bulbs.

**Map Light: 8 W**



1. Push on the lens of the opposite side you are replacing.
2. Pry on the edge between the lenses using a flat-tip screwdriver to remove the cover.
  - Wrap the flat-tip screwdriver with a cloth to prevent scratches.

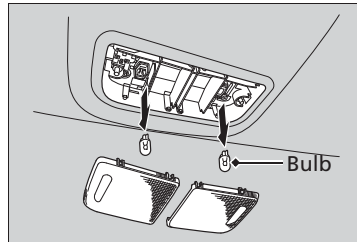

3. Remove the old bulb and insert a new bulb.

**Models with sunroof**

**Rear Map Light Bulbs \***

When replacing, use the following bulbs.

**Rear Map Light: 8 W**

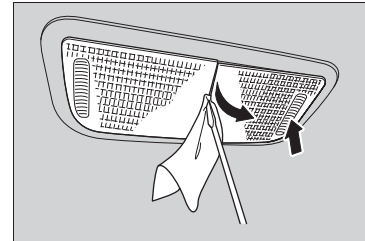

1. Push on the lens of the opposite side you are replacing.
2. Pry on the edge between the lenses using a flat-tip screwdriver to remove the cover.
  - Wrap the flat-tip screwdriver with a cloth to prevent scratches.

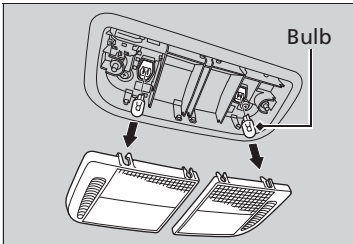

3. Remove the old bulb and insert a new bulb.

### ■ Boot Light Bulb

When replacing, use the following bulb.

**Boot Light: 5 W**

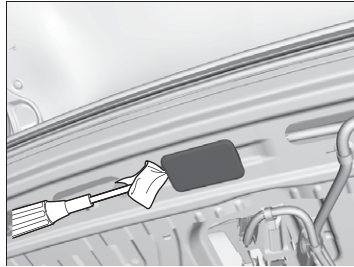

1. Pry on the edge of the cover using a flat-tip screwdriver to remove the cover.
  - ▶ Wrap the flat-tip screwdriver with a cloth to prevent scratches.

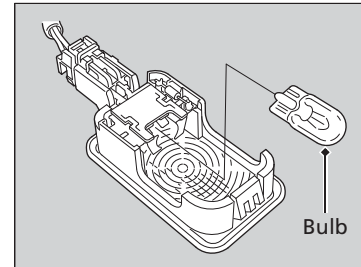

2. Remove the old bulb and insert a new bulb.

## Checking Wiper Blades

If the wiper blade rubber has deteriorated, it will leave streaks and the hard surfaces of the blade may scratch the window glass.

## Changing the Wiper Blade Rubber

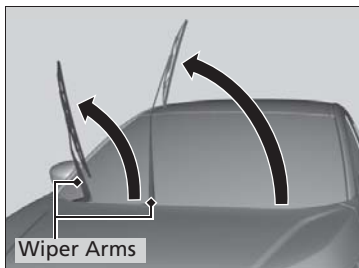

1. Lift the driver side wiper arm first, then the passenger side.

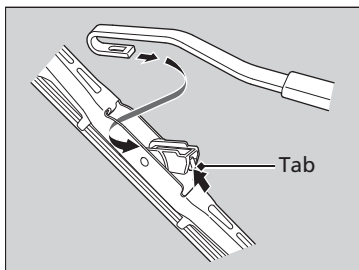

2. Press up on and hold the tab, then slide the holder off the wiper arm.

### Changing the Wiper Blade Rubber

#### NOTICE

Avoid dropping the wiper arm onto the windshield, it may damage the wiper arm and/or the windshield.



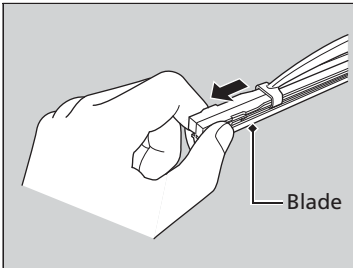

3. Slide the wiper blade out of the holder by pulling the tabbed end out.

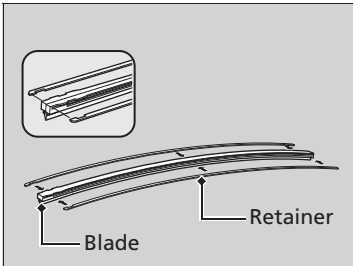

4. Remove the retainers from the wiper blade that has been removed, and mount to a new wiper blade.
  - ▶ Correctly align the wiper blade protrusion and the retainer grooves.
5. Slide the new wiper blade onto the holder from the bottom end.
  - ▶ The tab on the holder should fit in the indent of the wiper blade.
6. Slide the holder onto the wiper arm securely.
7. Lower the passenger side wiper arm first, then the driver side.

## Checking Tyres

To safely operate your vehicle, your tyres must be of the proper type and size, in good condition with adequate tread, and properly inflated.

### ■ Inflation guidelines

Properly inflated tyres provide the best combination of handling, tread life, and comfort. Refer to the driver's doorjamb label for the specified pressure.

Underinflated tyres wear unevenly, adversely affect handling and fuel economy, and are more likely to fail from overheating.

Overinflated tyres make your vehicle ride harshly, are more prone to road hazards, and wear unevenly.

Every day before you drive, look at each of the tyres. If one looks lower than the others, check the pressure with a tyre gauge.

At least once a month or before long trips, use a gauge to measure the pressure in all tyres, including the spare. Even tyres in good condition can lose 10-20 kPa (0.1-0.2 bar, 1-2 psi) per month.

### 🔍 Checking Tyres

## ⚠️ WARNING

Using tyres that are excessively worn or improperly inflated can cause a crash in which you can be seriously hurt or killed.

Follow all instructions in this owner's manual regarding tyre inflation and maintenance.

Measure the air pressure when tyres are cold. This means the vehicle has been parked for at least three hours, or driven less than 1.6 km. If necessary, add or release air until the specified pressure is reached.

If checked when hot, tyre pressure can be as much as 30–40 kPa (0.3-0.4 bar, 4-6 psi) higher than if checked when cold.

Have a dealer check the tyres if you feel a consistent vibration while driving. New tyres and any that have been removed and reinstalled should be properly balanced.

### Models with deflation warning system

Whenever tyre pressure is adjusted, you must calibrate the deflation warning system.

➡ **Deflation Warning System** \* P. 231

## ■ Inspection guidelines

Every time you check inflation, also examine the tyres and valve stems.

Look for:

- Bumps or bulges on the side or in the tread. Replace the tyre if you find any cuts, splits, or cracks in the side of the tyre. Replace it if you see fabric or cord.
- Remove any foreign objects and inspect for air leaks.
- Uneven tread wear. Have a dealer check the wheel alignment.
- Excessive tread wear.

📄 **Wear Indicators** P. 298

- Cracks or other damage around valve stem.

### 🔍 Checking Tyres

#### High speed driving

We recommend that you do not drive faster than the posted speed limits and conditions allow. If you drive at sustained high speeds (over 160 km/h), adjust the cold tyre pressures as shown below to avoid excessive heat build up and sudden tyre failure.

#### Models with 185/60R15 84H tyre

Tyre Size	185/60R15 84H
Pressure*1, *2	Front: 250 kPa (2.5 bar, 36 psi) Rear: 230 kPa (2.3 bar, 33 psi)
Pressure*3	Front: 240 kPa (2.4 bar, 35 psi)*4 250 kPa (2.5 bar, 36 psi)*5 Rear: 230 kPa (2.3 bar, 33 psi)*4 240 kPa (2.4 bar, 35 psi)*5
Pressure*6	Front: 250 kPa (2.5 bar, 36 psi) Rear: 240 kPa (2.4 bar, 35 psi)

\*1: Latin American models

\*2: Malaysian, Bangladeshi, Brunei and Singaporean models

\*3: Indian, Bhutanese, Nepalese and Sri Lankan models

\*4: Petrol models

\*5: Diesel models

\*6: African models

#### Models with 185/55R16 83H tyre

Tyre Size	185/55R16 83H
Pressure	Front: 250 kPa (2.5 bar, 36 psi) Rear: 240 kPa (2.4 bar, 35 psi)

#### Models with 185/55R16 87H tyre

Tyre Size	185/55R16 87H
Pressure	Front: 260 kPa (2.6 bar, 38 psi) Rear: 240 kPa (2.4 bar, 35 psi)

## Wear Indicators

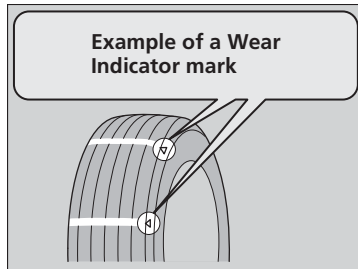

The groove where the wear indicator is located is about 1.6 mm shallower than elsewhere on the tyre. If the tread has worn so that the indicator is exposed, replace the tyre.

**Worn out tyres have poor traction on wet roads.**

## Tyre Service Life

The life of your tyres is dependent on many factors, including driving habits, road conditions, vehicle loading, inflation pressure, maintenance history, speed, and environmental conditions (even when the tyres are not in use).

In addition to regular inspections and inflation pressure maintenance, it is recommended that you have annual inspections performed once the tyres reach five years old. All tyres, including the spare, should be removed from service after 10 years from the date of manufacture, regardless of their condition or state of wear.

## Tyre and Wheel Replacement

Replace your tyres with radials of the same size, load range, speed rating, and maximum cold tyre pressure rating (as shown on the tyre's sidewall). Using tyres of a different size or construction can cause certain vehicle systems such as the ABS and Vehicle Stability Assist (VSA) system to work incorrectly.

It is best to replace all four tyres at the same time. If that isn't possible, replace the front or rear tyres in pairs.

Make sure that the wheel's specifications match those of the original wheels.

### ▶▶ Tyre and Wheel Replacement

#### **WARNING**

Installing improper tyres on your vehicle can affect handling and stability. This can cause a crash in which you can be seriously hurt or killed.

Always use the size and type of tyres recommended in the tyre information label on your vehicle.

## Tyre Rotation

Rotating tyres according to the maintenance schedule helps to distribute wear more evenly and increase tyre life.

### ■ Your Vehicle's Tyre Rotation Pattern

#### Models with a compact/temporary spare tyre

Rotate the tyres as shown here.

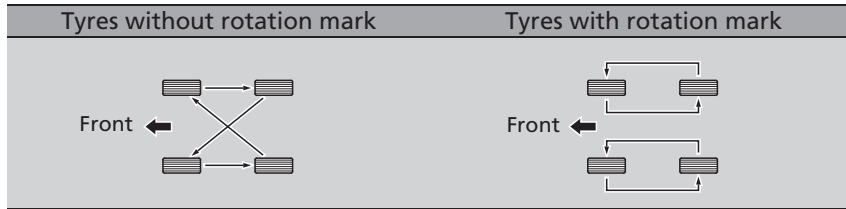

#### Models with a full-size spare tyre

Rotate the tyres, including a spare, as shown here.

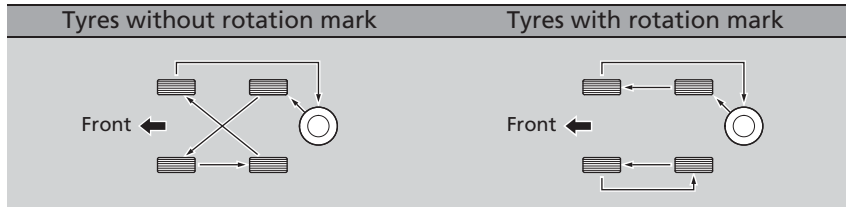

#### ► Tyre Rotation

Tyres with directional tread patterns should only be rotated front to back (not from one side to the other). Directional tyres should be mounted with the rotation indication mark facing forward, as shown below.

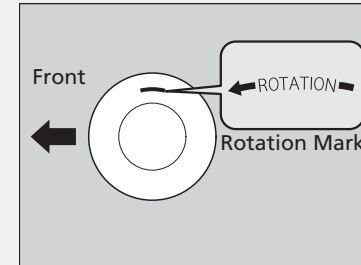

When the tyres are rotated, make sure the air pressures are checked.

#### Models with deflation warning system

Whenever tyres are rotated, you must calibrate the deflation warning system.

► **Deflation Warning System**\* P. 231

## Snow Traction Devices

If driving on snowy or frozen roads, mount winter tyres, or tyre chains; reduce speed; and maintain sufficient distance between vehicles when driving.

Be particularly careful when operating the steering wheel or brakes to prevent skidding.

Use tyre chains, winter tyres, or all season tyres when necessary or according to the law.

When mounting, refer to the following points.

For winter tyres:

- Select the size and load ranges that are the same as the original tyres.
- Mount the tyres to all four wheels.

For tyre chains:

- Consult a dealer before purchasing any type of chains for your vehicle.
- Install them on the front tyres only.
- Because your vehicle has limited tyre clearance, we strongly recommend using the chains listed below:

### Bhutanese models

Original Tyre Size* <sup>1</sup>	Chain Type
185/60R15 84H	RUD-matic classic 48478
185/55R16 83H	RUD-matic classic 48479
185/55R16 87H	

\*1: Original tyre size is mentioned on the tyre information label on the driver's doorjamb.

### ❖ Snow Traction Devices

## ⚠ WARNING

Using the wrong chains, or not properly installing chains, can damage the brake lines and cause a crash in which you can be seriously injured or killed.

Follow all instructions in this owner's manual regarding the selection and use of tyre chains.

### NOTICE

Traction devices that are the wrong size or improperly installed can damage your vehicle's brake lines, suspension, body, and wheels. Stop driving if they are hitting any part of the vehicle.

When tyre chains are mounted, follow the chain manufacturer's instructions regarding vehicle operational limits.

Use tyre chains only in an emergency or when they are legally required for driving through a certain area.

Use greater caution when driving with tyre chains on snow or ice. They may have less-predictable handling than good winter tyres without chains.

- Follow the chain manufacturer's instruction when installing. Mount them as tightly as you can.
- Check that the chains do not touch the brake lines or suspension.
- Drive slowly.

#### ☒ Snow Traction Devices

If your vehicle is equipped with summer tyres, be aware that these tyres are not designed for winter driving conditions. For more information, contact a dealer.



## Checking the Battery

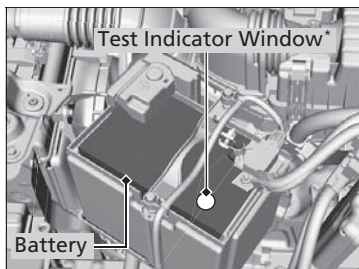

### Models with test indicator window on the battery

Check the battery condition monthly. Look at the test indicator window and check the terminals for corrosion.

The battery condition is monitored by the sensor on the negative terminal. If there is a problem with the sensor, the warning message on information display\*/driver information interface\* will let you know. Have your vehicle checked by a dealer.

### Models without test indicator window on the battery

The condition of the battery is monitored by a sensor located on the negative terminal of the battery. If there is a problem with this sensor, the information display\*/driver information interface\* will display a warning message. If this happens, have your vehicle inspected by a dealer.

Check the battery terminals for corrosion monthly.

If your vehicle's battery is disconnected or goes dead:

- The clock resets.
  - **Clock** P. 124

\* Not available on all models

### ⌘ Battery

## ⚠ WARNING

The battery gives off explosive hydrogen gas during normal operation.

A spark or open flame can cause the battery to explode with enough force to kill or seriously hurt you.

Keep all sparks, open flames, and smoking materials away from the battery.

Wear protective clothing and a face shield, or have a skilled technician do any battery maintenance.

## ⚠ WARNING

The battery contains sulfuric acid (electrolyte) which is highly corrosive and poisonous.

Getting electrolyte in your eyes or on your skin can cause serious burns. Wear protective clothing and eye protection when working on or near the battery.

Swallowing electrolyte can cause fatal poisoning if immediate action is not taken.

KEEP OUT OF THE REACH OF CHILDREN

## Charging the Battery

Disconnect both battery cables to prevent damaging your vehicle's electrical system. Always disconnect the negative (-) cable first, and reconnect it last.

### ▶▶ Battery

#### Emergency Procedures

Eyes: Flush with water from a cup or other container for at least 15 minutes. (Water under pressure can damage the eye.) Call a physician immediately.

Skin: Remove contaminated clothing. Flush the skin with large quantities of water. Call a physician immediately.

Swallowing: Drink water or milk. Call a physician immediately.

When you find corrosion, clean the battery terminals by applying a baking powder and water solution. Clean the terminals with a damp towel. Cloth/towel dry the battery. Coat the terminals with grease to help prevent future corrosion.

When replacing the battery, the replacement must be of the same specifications. Consult a dealer for more information.

#### Models with test indicator window on the battery

The test indicator's colour information is on the battery.

The location of the test indicator window may vary depending on the model.

## ▶▶ Battery

The indicators for the Vehicle Stability Assist (VSA) system, Vehicle Stability Assist (VSA) OFF, and low tyre pressure/deflation warning system indicator\* may come on along with a message in the driver information interface\* when you set the power mode to ON after re-connecting a battery.

Drive a short distance at more than 20 km/h. Each indicator should go off. If it does not, have your vehicle checked by a dealer.

\* Not available on all models

## Replacing the Button Battery

If the indicator does not come on when the button is pressed, replace the battery.



### Battery type: CR2032

1. Remove the built-in key.
2. Remove the upper half of the cover by carefully prying on the edge with a coin.
  - ▶ Wrap a coin with a cloth to prevent scratching the keyless remote.
  - ▶ Remove carefully to avoid losing the buttons.
3. Make sure to replace the battery with the correct polarity.

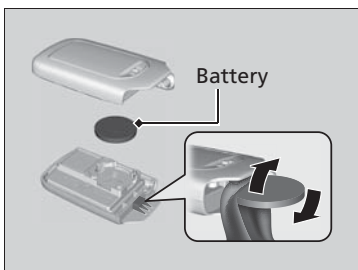

### Replacing the Button Battery

## **⚠ WARNING**

### CHEMICAL BURN HAZARD

The battery that powers the remote transmitter can cause severe internal burns and can even lead to death if swallowed. Keep new and used batteries away from children.

If you suspect that a child has swallowed the battery, seek medical attention immediately.

### NOTICE

An improperly disposed of battery can damage the environment. Always confirm local regulations for battery disposal.

Replacement batteries are commercially available or at a dealer.

## Dust and Pollen Filter

### ■ When to Replace the Dust and Pollen Filter

Replace the dust and pollen filter according to your vehicle's recommended maintenance schedule. It is recommended to replace the filter even sooner if the vehicle has been driven in a dusty environment.

➤ **Maintenance Schedule** P. 255

### ■ How to Replace the Dust and Pollen Filter



1. Open the glove box.

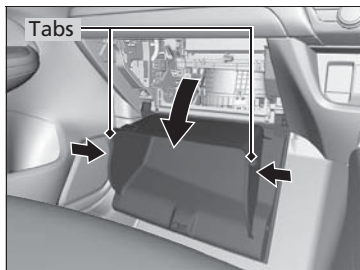

2. Disengage the two tabs by pushing on each side panel.

3. Pivot the glove box out of the way.

### ☒ Dust and Pollen Filter

If the airflow from the cooling system\*/climate control system\* deteriorates noticeably, and the windows fog up easily, the filter may need to be replaced.

The dust and pollen filter collects pollen, dust, and other debris in the air.

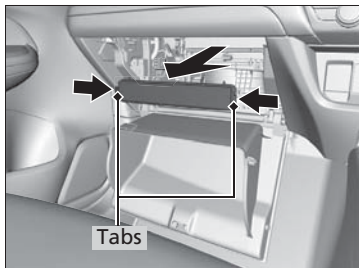

4. Push in the tabs on the corners of the filter case cover, and remove it.

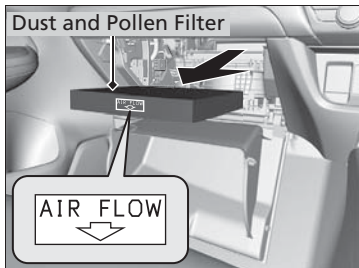

5. Remove the filter from the case.
6. Install a new filter in the case.
  - Put the **AIR FLOW** arrow directed side down.

#### ►► Dust and Pollen Filter

If you are not sure how to replace the dust and pollen filter, have it replaced by a dealer.

## Interior Care

Use a vacuum cleaner to remove dust before using a cloth.

Use a damp cloth with a mixture of mild detergent and warm water to remove dirt.

Use a clean cloth to remove detergent residue.

### Cleaning Seat Belts

Use a soft brush with a mixture of mild soap and warm water to clean the seat belts.

Let the belts air dry. Wipe the openings of the seat belt anchors using a clean cloth.

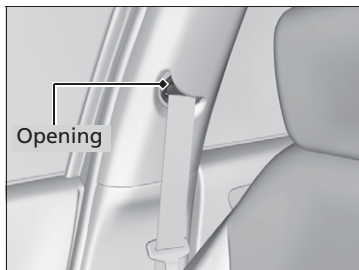

### Interior Care

Do not spill liquids inside the vehicle.

Electrical devices and systems may malfunction if liquids are splashed on them.

Do not use silicone based sprays on electrical devices such as audio devices and switches.

Doing so may cause the items to malfunction or cause a fire inside the vehicle.

If a silicone based spray is inadvertently used on electrical devices, consult a dealer.

Depending on their composition, chemicals and liquid aromatics may cause discoloration, wrinkles, and cracking to resin-based parts and textiles.

Do not use alkali solvents or organic solvents such as benzene or petrol.

After using chemicals, make sure to gently wipe them away using a dry cloth.

Do not place used cloths on top of resin based parts or textiles for long periods of time without washing.

Be careful not to spill a liquid type air freshener.

## ■ Cleaning the Window

Wipe using a glass cleaner.

## ■ Floor Mats\*

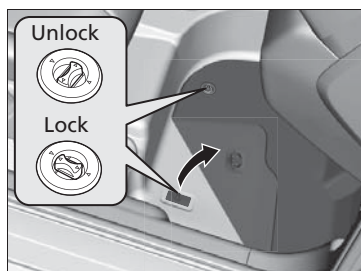

The driver's floor mat hooks over the floor anchors, which keep the mat from sliding forward. To remove a mat for cleaning, turn the anchor knobs to the unlock position. When reinstalling the mat after cleaning, turn the knobs to the lock position.

**Do not put additional floor mats on top of the anchored mat.**

## ■ Maintaining Genuine Leather\*

To properly clean leather:

1. Use a vacuum or soft dry cloth first to remove any dirt or dust.
2. Clean the leather with a soft cloth dampened with a solution comprised of 90% water and 10% neutral soap.
3. Wipe away any soap residue with a clean damp cloth.
4. Wipe away residual water and allow leather to air dry in the shade.

## ☒ Cleaning the Window

Wires are mounted to the inside of the rear window. Wipe along the same direction as the wires with a soft cloth so as not to damage them.

## ☒ Floor Mats\*

If you use any floor mats that were not originally provided with your vehicle, make sure they are designed for your specific vehicle, fit correctly, and are securely anchored by the floor anchors. Position the rear seat floor mats properly. If they are not properly positioned, the floor mats can interfere with the front seat functions.

## ☒ Maintaining Genuine Leather\*

It is important to clean or wipe away dirt or dust as soon as possible. Spills can soak into leather resulting in stains. Dirt or dust can cause abrasions in the leather. In addition, please note that some dark coloured clothing can rub onto the leather seats resulting in discolouration or stains.



## Exterior Care

Dust off the vehicle body after you drive. Regularly inspect your vehicle for scratches on painted surfaces. A scratch on a painted surface can result in body rust. If you find a scratch, promptly repair it.

### ■ Washing the Vehicle

Wash the vehicle regularly. Wash more frequently when driving in the following conditions:

- If driving on roads with road salt.
- If driving in coastal areas.
- If tar, soot, bird droppings, insects, or tree sap are stuck to painted surfaces.

### ■ Using an Automated Car Wash

- Make sure to follow the instructions indicated on the automated car wash.
- Fold in the door mirrors.

### ■ Using High Pressure Cleaners

- Keep sufficient distance between the cleaning nozzle and the vehicle body.
- Take particular care around the windows. Standing too close may cause water to enter the vehicle interior.
- Do not spray high pressure water directly into the engine compartment. Instead, use low pressure water and a mild detergent.

### ▶▶ Washing the Vehicle

Do not spray water into the air intake vents. It can cause a malfunction.

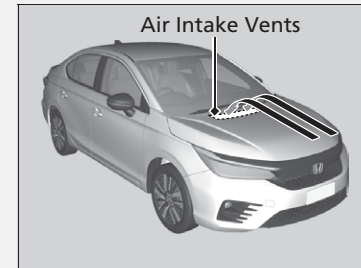

*Continued*

## ■ Applying Wax

A good coat of automotive body wax helps to protect your vehicle's paint from the elements. Wax will wear off over time and expose your vehicle's paint to the elements, so reapply as necessary.

## ■ Maintaining the Bumpers and Other Resin Coated Parts

If you get petrol, oil, engine coolant, or battery fluid on resin coated parts, they may be stained or the coating may peel. Promptly wipe it away using a soft cloth and clean water.

## ■ Cleaning the Window

Wipe using a glass cleaner.

## ■ Maintaining Aluminium Wheels

Aluminium is susceptible to deterioration caused by salt and other road contaminants. When necessary, as early as possible use a sponge and mild detergent to wipe away these contaminants. Do not use a stiff brush or harsh chemicals (including some commercial wheel cleaners). These can damage the protective finish on aluminium alloy wheels, resulting in corrosion. Depending on the type of finish, the wheels also may lose their lustre or appear burnished. To avoid water stains, wipe the wheels dry with a cloth while they are still wet.

## ►► Applying Wax

### NOTICE

Chemical solvents and strong cleaners can damage the paint, metal, and plastic on your vehicle. Wipe away spills immediately.

## ►► Maintaining the Bumpers and Other Resin Coated Parts

Ask a dealer about the correct coating material when you want to repair the painted surface of the parts made of resin.

## ■ Fogged Exterior Light Lenses

The inside lenses of exterior lights (headlights, brake lights, etc.) may fog temporarily if you have driven in the rain, or after the vehicle has been run through a car wash. Dew condensation also may build up inside the lenses when there is a significant enough difference between the ambient and inside lens temperatures (similar to vehicle windows fogging up in rainy conditions). These conditions are natural processes, not structural design problems in the exterior lights.

Lens design characteristics may result in moisture developing on the light lens frame surfaces. This also is not a malfunction.

However, if you see large amounts of water accumulation, or large water drops building up inside the lenses, have your vehicle inspected by a dealer.

## Accessories

When installing accessories, check the following:

- Do not install accessories on the windshield. They can obstruct your view and delay your reaction to driving conditions.
- Do not install any accessories over areas marked SRS Airbag, on the sides or backs of the front seats, on front or side pillars, or near the side windows. Accessories installed in these areas may interfere with proper operation of the vehicle's airbags or may be propelled into you or another occupant if the airbags deploy.
- Be sure electronic accessories do not overload electrical circuits or interfere with proper operation of your vehicle.
  - **Fuses** P. 348
- Before installing any electronic accessory, have the installer contact a dealer for assistance. If possible, have a dealer inspect the final installation.

### Accessories and Modifications

#### **WARNING**

**Improper accessories or modifications can affect your vehicle's handling, stability, and performance, and cause a crash in which you can be seriously hurt or killed.**

**Follow all instructions in this owner's manual regarding accessories and modifications.**

When properly installed, mobile phones, alarms, two-way radios, radio antennas, and low-powered audio systems should not interfere with your vehicle's computer controlled systems, such as your airbags and anti-lock brakes.

Honda Genuine accessories are recommended to ensure proper operation on your vehicle.

## Modifications

---

Do not modify your vehicle in a manner that may affect its handling, stability, or reliability, or install non-genuine Honda parts or accessories that may have a similar effect.

Even minor modifications to vehicle systems can affect overall vehicle performance. Always make sure all equipment is properly installed and maintained, and do not make any modification to your vehicle or its systems that might cause your vehicle to no longer meet your country's and local regulations.

The on-board diagnostic port (OBD-II/SAE J1962 connector) installed on this vehicle is intended to be used with automobile system diagnostic devices or with other devices that Honda has approved. Use of any other type of device may adversely affect the vehicle's electronic systems or allow them to be compromised, possibly resulting in a system malfunction, drained battery, or other unexpected problems.

Do not modify or attempt to repair any of the electrical components.



# Handling the Unexpected

This chapter explains how to handle unexpected troubles.

## Tools

Types of Tools ..... 318

## If a Tyre Goes Flat

Changing a Flat Tyre ..... 319

## Engine Does Not Start

Checking the Engine ..... 329

**Models with information display**

If the Keyless Remote Battery is Weak ... 331

Emergency Engine Stop ..... 332

**Jump Starting** ..... 333

**Shift Lever Does Not Move** ..... 337

## Overheating

How to Handle Overheating ..... 338

## Indicator, Coming On/Blinking

**Models with information display**

If the Low Oil Pressure Indicator Comes On ..... 340

**Models with driver information interface**

If the Low Oil Pressure Warning Appears... 341

If the Charging System Indicator Comes On.. 342

If the Malfunction Indicator Lamp Comes On or Blinks ..... 343

If the Brake System Indicator (Red) Comes On ..... 343

If the Electric Power Steering (EPS) System Indicator Comes On ..... 344

**Indian, Bhutanese, Nepalese and Sri Lankan models**

If the Low Tyre Pressure/Deflation Warning System Indicator Comes On or Blinks .. 345

**Diesel models with information display**

If the PGM-FI Indicator Comes On.... 346

**Diesel models with driver information interface**

If the PGM-FI Symbol Appears ..... 347

## Fuses

Fuse Locations ..... 348

Inspecting and Changing Fuses ..... 361

**Emergency Towing** ..... 362

## Types of Tools

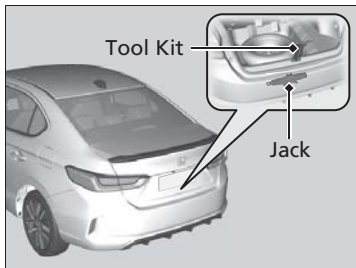
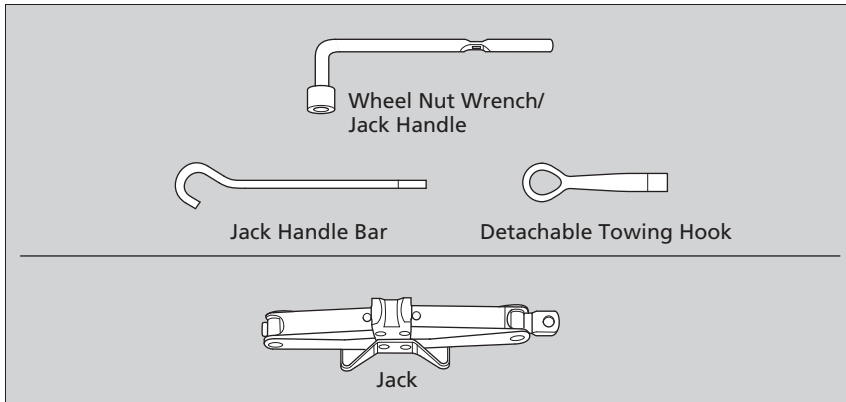

### Types of Tools

The tools are stored in the boot.



## Changing a Flat Tyre

If a tyre goes flat while driving, grasp the steering wheel firmly, and brake gradually to reduce speed. Then, stop in a safe place. Replace the flat tyre with a compact spare tyre\*/temporary spare tyre\*/full-size spare tyre\*. Go to a dealer as soon as possible to have the full-size tyre repaired or replaced.

1. Park the vehicle on a firm, level, non-slippery surface and apply the parking brake.

### Continuously variable transmission models

2. Put the transmission into **P**.

### Manual transmission models

2. Put the transmission into **R**.

### All models

3. Turn on the hazard warning lights and set the power mode to VEHICLE OFF (LOCK).

### Changing a Flat Tyre

Follow compact/temporary spare\* precautions:

#### Compact spare tyre

Periodically check the tyre pressure of the compact spare. It should be set to the specified pressure. Specified Pressure: 420 kPa (4.2 bar, 60 psi)

#### Temporary spare tyre

Check the air pressure of the 175/65R15 size temporary spare tyre every time you check the other full-size tyres. It should be inflated to the recommended air pressure on the label attached to the driver's doorjamb.

#### Compact spare tyre

When driving with the compact spare tyre, keep the vehicle speed under 80 km/h. Replace with a full-size tyre as soon as possible.

#### Temporary spare tyre

When driving with the temporary spare tyre, keep the vehicle speed under 120 km/h. Replace with a full-size tyre as soon as possible.

The compact/temporary spare tyre and wheel in your vehicle are specifically for this model. Do not use them with another vehicle. Do not use another type of compact/temporary spare tyre or wheel with your vehicle.

\* Not available on all models

#### ► Changing a Flat Tyre

Do not mount tyre chains on a compact/temporary spare tyre.

If a chain-mounted front tyre goes flat, remove one of the full-size rear tyres and replace it with the compact/temporary spare tyre. Remove the flat front tyre and replace it with the full-size tyre that was removed from the rear. Mount the tyre chains on the front tyre.

A compact spare tyre gives a harsher ride and less traction on some road surfaces. Use greater caution while driving.

## ■ Getting Ready to Replace the Flat Tyre

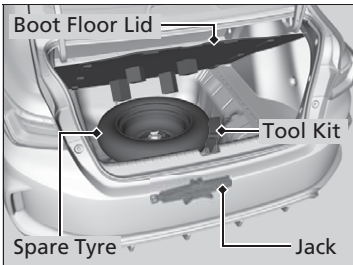

1. Open the boot floor lid.

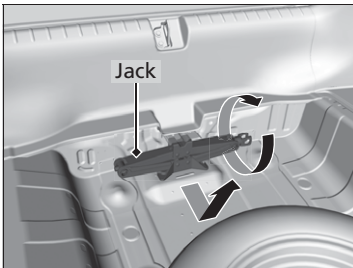

2. Take the tool kit and jack out of the boot.

▶ Remove the jack by turning the jack's end bracket to the left to loosen it.

3. Unscrew the wing bolt, and remove the spacer cone. Then, remove the spare tyre.

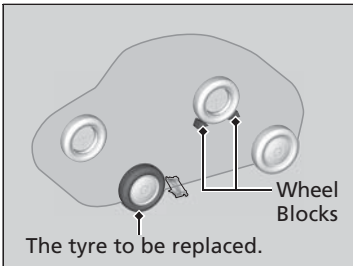

4. Place a wheel block or rock in front and rear of the wheel diagonal to the flat tyre.

## ▣ Changing a Flat Tyre

The compact/temporary spare tyre is smaller than the regular tyre. Your vehicle's ground clearance reduces when the compact/temporary spare tyre is installed. Driving over road debris or bumps could possibly damage the underside of your vehicle.

**WARNING:** The jack can only be used for helping an emergency vehicle breakdown, not for changing the regular seasonal tyre or any other normal maintenance or repair operation.

### NOTICE

Do not use the jack if it doesn't work properly. Call your dealer or a professional towing service.

Do not use more than one compact/temporary spare tyre at the same time.

Continued



5. Place the spare tyre (wheel side up) under the vehicle body, near the tyre that needs to be replaced.



6. Loosen each wheel nut about one turn using the wheel nut wrench.

## How to Set Up the Jack

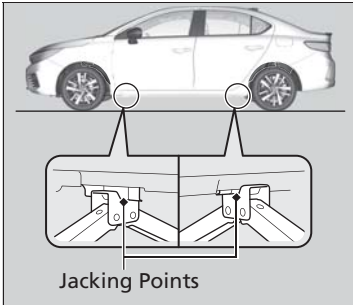

1. Place the jack under the jacking point closest to the tyre to be changed.

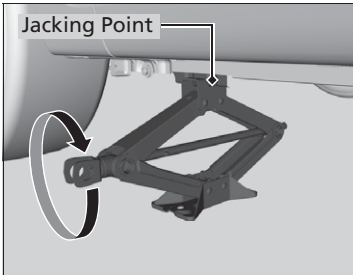

2. Turn the end bracket clockwise as shown in the image until the top of the jack contacts the jacking point.
  - ▶ Make sure that the jacking point tab is resting in the jack notch.

### How to Set Up the Jack

#### **⚠ WARNING**

The vehicle can easily roll off the jack, seriously injuring anyone underneath.

Follow the directions for changing a tyre exactly, and no person should place any portion of their body under a vehicle that is supported by a jack.

**WARNING:** The jack shall be placed on a flat and stable surface on the same level as the vehicle is parked.

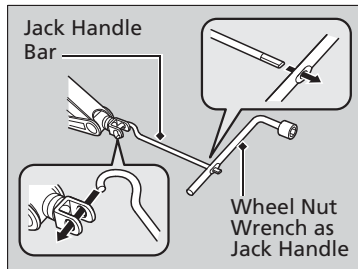

3. Raise the vehicle, using the jack handle bar and the jack handle, until the tyre is off the ground.

#### ▶ How to Set Up the Jack

Do not use the jack with people or luggage in the vehicle.

Use the jack provided in your vehicle. Other jacks may not support the weight ("load") or may not fit the jacking point.

The following instructions must be followed to use the jack safely:

- Do not use while the engine is running.
- Use only where the ground is firm and level.
- Use only at the jacking points.
- Do not get in the vehicle while using the jack.
- Do not put anything on top of or underneath the jack.

## ■ Replacing the Flat Tyre

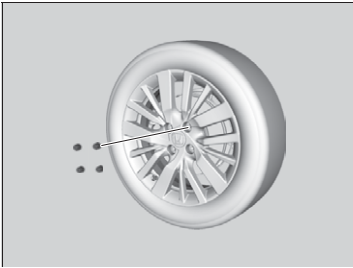

1. Remove the wheel nuts and flat tyre.

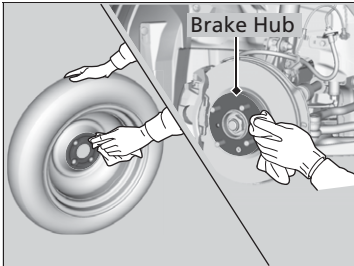

2. Wipe the mounting surfaces of the wheel with a clean cloth.
3. Mount the spare tyre.
4. Screw the wheel nuts until they touch the lips around the mounting holes, then stop rotating.

## ▣ Replacing the Flat Tyre

Do not over tighten the wheel nuts by applying extra torque using your foot or a pipe.

*Continued*

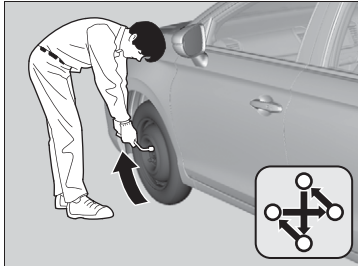

5. Lower the vehicle and remove the jack.  
Tighten the wheel nuts in the order indicated in the image. Go around, tightening the nuts, two to three times in this order.

**Wheel nut torque:**

108 N·m (11 kgf·m, 80 lbf·ft)



## Storing the Flat Tyre

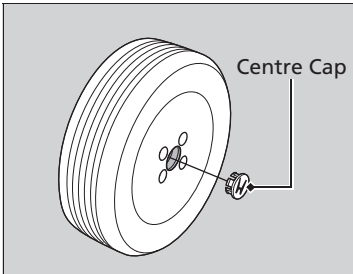

1. Remove the centre cap.

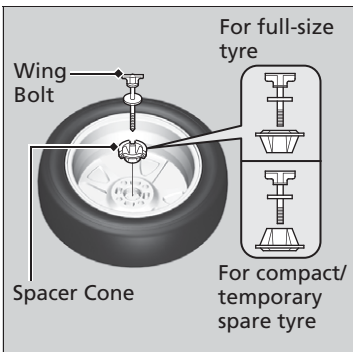

2. Place the flat tyre face down in the spare tyre well.
3. Remove the spacer cone from the wing bolt, flip it over, and insert it back on the bolt. Secure the flat tyre with the wing bolt.
4. Securely store the wheel nut wrench and jack handle bar back in the tool bag. Store the tool bag and jack in the boot.

### Storing the Flat Tyre

## ⚠ WARNING

Loose items can fly around the interior in a crash and can seriously injure the occupants.  
Store the wheel, jack, and tools securely before driving.

Indian, Bhutanese, Nepalese and Sri Lankan models

## ■ Deflation Warning System and the Spare Tyre

If you replace a flat tyre with the spare tyre, the low tyre pressure/deflation warning system indicator comes on while you are driving. After driving for a few kilometres, **Tyre Pressure Monitor System Problem** will appear on the driver information interface\* and the indicator will start blinking for a short time and then stay on; however, this is normal and is no cause for concern.

Calibrate the deflation warning system when you replace the tyre with a specified regular tyre.

➤ **Deflation Warning System Initialisation** P. 232

## Checking the Engine

If the engine does not start, check the starter.

### » Checking the Engine

If you must start the vehicle immediately, use an assisting vehicle or booster battery to jump start it.

➤ **Jump Starting** P. 333

Do not hold the **ENGINE START/STOP** button for more than 15 seconds.

### Starter condition

### Checklist

#### Starter doesn't turn or turns over slowly.

The battery may be dead. Check each of the items on the right and respond accordingly.

#### Check for a message on the information display\* or driver information interface\*.

##### Models with information display

- If the **KEY BATT** message appears

##### Models with driver information interface

- If the **To Start, Hold Remote Near Start Button** message appears
  - **If the Keyless Remote Battery is Weak** P. 331
- ▶ Make sure the keyless remote is in its operating range
  - **ENGINE START/STOP Button Operating Range** P. 157

#### Check the brightness of the interior lights.

Turn on the interior lights and check the brightness.

- If the interior lights are dim or do not come on at all ➤ **Battery** P. 303
- If the interior lights come on normally ➤ **Fuses** P. 348

Starter condition	Checklist
<p><b>The starter turns over normally but the engine doesn't start.</b> There may be a problem with the fuse. Check each of the items on the right and respond accordingly.</p>	<p><b>Review the engine start procedure.</b> Follow its instructions, and try to start the engine again. ➤ <b>Starting the Engine</b> P. 206</p> <hr/> <p><b>Check the immobilizer system indicator.</b> When the immobilizer system indicator is blinking, the engine cannot be started. ➤ <b>Immobilizer System</b> P. 149</p> <hr/> <p><b>Check the fuel level.</b> There should be enough fuel in the tank. ➤ <b>Fuel Gauge</b> P. 104</p> <hr/> <p><b>Check the fuse.</b> Check all fuses, or have the vehicle checked by a dealer. ➤ <b>Inspecting and Changing Fuses</b> P. 361</p> <hr/> <p><b>If the problem continues:</b> ➤ <b>Emergency Towing</b> P. 362</p>
<p><b>The starter turns over normally but the engine doesn't start.</b> There may be a problem with the fuses. Check each of the items on the right and respond accordingly.</p>	<p><b>Diesel models</b></p> <p><b>Check the malfunction indicator lamp comes on, or the PGM-FI indicator comes on* or the PGM-FI Engine Control System Problem. Power May Be Reduced. message appears* in the instrument panel under the following circumstances:</b></p> <ul style="list-style-type: none"> <li>The fuel tank has been run dry. ➤ <b>Malfunction Indicator Lamp</b> P. 91 ➤ <b>PGM-FI Indicator*</b> P. 102</li> </ul> <p><b>Diesel models</b></p> <p><b>Have the fuel filter checked to drain off water.</b> The water in fuel indicator comes on in the instrument panel. ➤ <b>Water in Fuel Indicator*</b> P. 102</p>

## If the Keyless Remote Battery is Weak

### Models with information display

If the beeper sounds, the **KEY BATT** message appears on the information display, and the **ENGINE START/STOP** button flashes, and the engine won't start, start the engine as follows:

### Models with driver information interface

If the beeper sounds, the **To Start, Hold Remote Near Start Button** message appears on the driver information interface, and the **ENGINE START/STOP** button flashes, and the engine won't start, start the engine as follows.

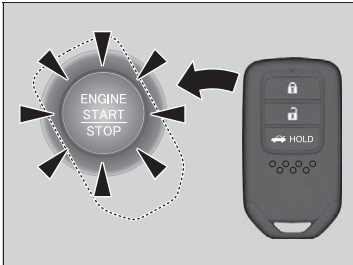

1. Touch the centre of the **ENGINE START/STOP** button with the **H** logo on the keyless remote while the **ENGINE START/STOP** button is flashing. The buttons on the keyless remote should be facing you.
  - ▶ The **ENGINE START/STOP** button flashes for about 30 seconds.

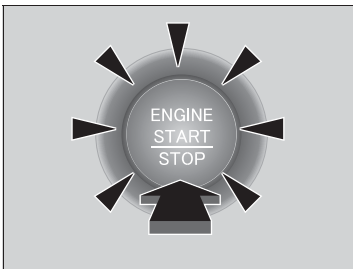

2. Depress the brake pedal (continuously variable transmission) or clutch pedal (manual transmission) and press the **ENGINE START/STOP** button within 10 seconds after the beeper sounds and the **ENGINE START/STOP** button changes from flashing to on.
  - ▶ If you don't depress the pedal, the mode will change to ACCESSORY.

## Emergency Engine Stop

The **ENGINE START/STOP** button may be used to stop the engine due to an emergency situation even while driving. If you must stop the engine, do either of the following operations:

- Press and hold the **ENGINE START/STOP** button for about two seconds.
- Firmly press the **ENGINE START/STOP** button three times.

The steering wheel will not lock.

### Continuously variable transmission models

The power mode is in ACCESSORY when the engine is stopped.

To change the mode to VEHICLE OFF, put the transmission into **P** after the vehicle comes to a complete stop.

Then press the **ENGINE START/STOP** button twice without depressing the brake pedal.

### Manual transmission models

The power mode changes to VEHICLE OFF.

### Emergency Engine Stop

Do not press the **ENGINE START/STOP** button while driving unless it is absolutely necessary for the engine to be turned off.

If you press the **ENGINE START/STOP** button while driving, the beeper sounds.

## Jump Starting Procedure

Turn off the power to electric devices, such as audio and lights. Turn off the engine, then open the bonnet.

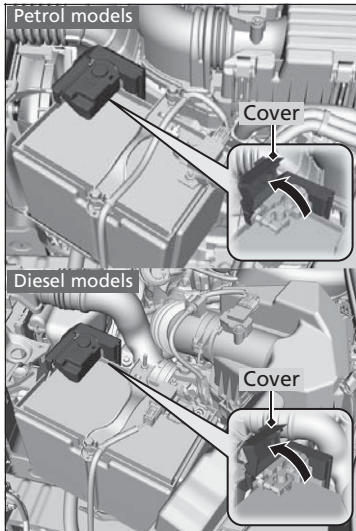

1. Open the terminal cover on your vehicle's battery positive ⊕ terminal.

### Jump Starting

## ⚠ WARNING

A battery can explode if you do not follow the correct procedure, seriously injuring anyone nearby.

Keep all sparks, open flames, and smoking materials away from the battery.

### NOTICE

If a battery sits in extreme cold, the electrolyte inside can freeze. Attempting to jump start with a frozen battery can cause it to rupture.

Securely attach the jumper cables clips so that they do not come off when the engine vibrates. Also be careful not to tangle the jumper cables or allow the cable ends to touch each other while attaching or detaching the jumper cables.

Battery performance degrades in cold conditions and may prevent the engine from starting.

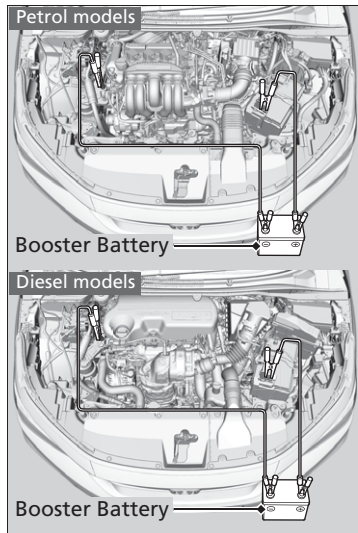

2. Connect the first jumper cable to your vehicle's ⊕ terminal.
3. Connect the other end of the first jumper cable to the booster battery ⊕ terminal.
  - ▶ Use a 12-volt booster battery only.
  - ▶ When using an automotive battery charger to boost your 12-volt battery, select a lower charging voltage than 15-volt. Check the charger manual for the proper setting.
4. Connect the second jumper cable to the booster battery ⊖ terminal.



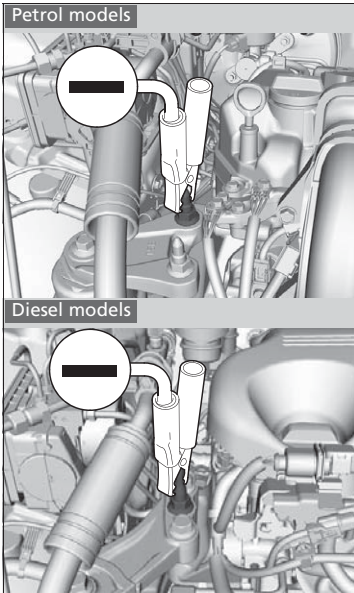

5. Connect the other end of the second jumper cable to the engine mounting bolt as shown. Do not connect this jumper cable to any other part.
6. If your vehicle is connected to another vehicle, start the assisting vehicle's engine and increase its rpm slightly.
7. Attempt to start your vehicle's engine. If it turns over slowly, check that the jumper cables have good metal-to-metal contact.

## ■ What to Do After the Engine Starts

Once your vehicle's engine has started, remove the jumper cables in the following order.

1. Disconnect the jumper cable from your vehicle's ground.
2. Disconnect the other end of the jumper cable from the booster battery ⊖ terminal.
3. Disconnect the jumper cable from your vehicle's battery ⊕ terminal.
4. Disconnect the other end of the jumper cable from the booster battery ⊕ terminal.

Have your vehicle inspected by a nearby service station or a dealer.

## ▶▶ Jump Starting

The indicators for the Vehicle Stability Assist (VSA) System, Vehicle Stability Assist (VSA) OFF may come on when you set the power mode to ON after reconnecting a battery.

Drive a short distance at more than 20 km/h. Each indicator should go off. If it does not, have your vehicle checked by a dealer.

# Shift Lever Does Not Move

## Continuously variable transmission models

Follow the procedure below if you cannot move the shift lever out of the **P** position.

### Releasing the Lock

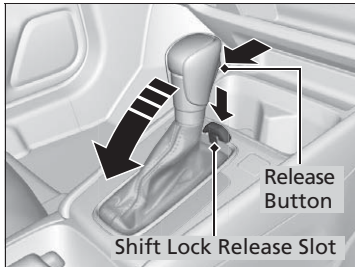

1. Set the parking brake.
2. Remove the built-in key from the keyless remote.
3. Insert the key into the shift lock release slot.
4. While pushing the key down, press the shift lever release button, and place the shift lever into **N**.
  - ▶ The lock is now released. Have the shift lever checked by a dealer as soon as possible.

## How to Handle Overheating

Overheating symptoms are as follows:

- The high temperature indicator comes on or the engine suddenly loses power.

### Models with driver information interface

- **Engine Temperature Too Hot. Allow Engine To Cool.** message appears on the driver information interface.

### All models

- Steam or spray comes out of the engine compartment.

### ■ First thing to do

1. Immediately park the vehicle in a safe place.
2. Turn off all accessories and turn on the hazard warning lights.
  - ▶ **No steam or spray present:**  
Keep the engine running and open the bonnet.
  - ▶ **Steam or spray is present:**  
Turn off the engine and wait until it subsides. Then, open the bonnet.

### » How to Handle Overheating

## **WARNING**

Steam and spray from an overheated engine can seriously scald you.

Do not open the bonnet if steam is coming out.

### NOTICE

Continuing to drive with the high temperature indicator on may damage the engine.

### Models with driver information interface

Continuing to drive with the **Engine Temperature Too Hot. Allow Engine To Cool.** message on the driver information interface may damage the engine.

### ■ Next thing to do

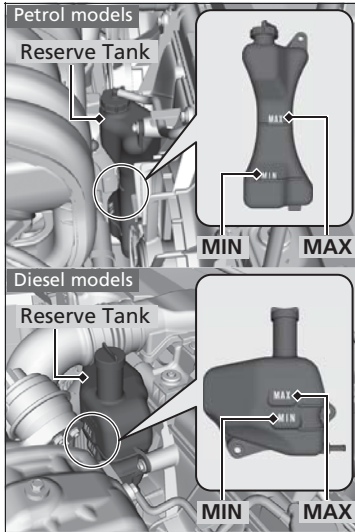

1. Check that the cooling fan is operating and stop the engine once the high temperature indicator goes off.
  - ▶ If the cooling fan is not operating, immediately stop the engine.
2. Once the engine has cooled down, inspect the coolant level and check the cooling system components for leaks.
  - ▶ If the coolant level in the reserve tank is low, add coolant until it reaches the **MAX** mark.
  - ▶ If there is no coolant in the reserve tank, check that the radiator is cool. Cover the radiator cap with a heavy cloth and open the cap. If necessary, add coolant up to the base of the filler neck, and put the cap back on.

### ■ Last thing to do

Once the engine has cooled sufficiently, restart it and check the high temperature indicator.

If the high temperature indicator is off, resume driving. If it stays on, contact a dealer for repairs.

#### ▶▶ How to Handle Overheating

### ⚠ WARNING

Removing the radiator cap while the engine is hot can cause the coolant to spray out, seriously scalding you.

Always let the engine and radiator cool down before removing the radiator cap.

If the coolant is leaking, contact a dealer for repairs.

Use water as an emergency/temporary measure only. Have a dealer flush the system with proper antifreeze as soon as possible.

Models with information display

## If the Low Oil Pressure Indicator Comes On



### ■ Reasons for the indicator to come on

Comes on when the engine oil pressure is low.

### ■ What to do as soon as the indicator comes on

1. Immediately park the vehicle on level ground in a safe place.
2. If necessary, turn the hazard warning lights on.

### ■ What to do after parking the vehicle

1. Stop the engine and let it sit for approximately three minutes.
2. Open the bonnet and check the oil level.

➤ **Oil Check** P. 268

3. Start the engine and check the low oil pressure indicator.

- ▶ The indicator goes off: Start driving again.
- ▶ The indicator does not go off within 10 seconds: Immediately stop the engine and contact a dealer for repairs.

### ➤ If the Low Oil Pressure Indicator Comes On

#### NOTICE

Running the engine with low oil pressure can cause serious mechanical damage almost immediately.

Models with driver information interface

## If the Low Oil Pressure Warning Appears

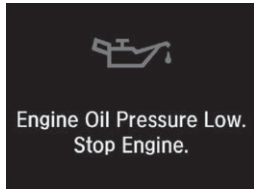

### ■ Reasons for the warning to appear

Appears when the engine oil pressure is low.

### ■ What to do as soon as the warning appears

1. Immediately park the vehicle on level ground in a safe place.
2. If necessary, turn the hazard warning lights on.

### ■ What to do after parking the vehicle

1. Stop the engine and let it sit for approximately three minutes.
2. Open the bonnet and check the oil level.  
➤ **Oil Check** P. 268
3. Start the engine and check the low oil pressure warning.
  - ▶ The warning disappears: Start driving again.
  - ▶ The warning does not disappear: Immediately stop the engine and contact a dealer for repairs.

### ▶▶ If the Low Oil Pressure Warning Appears

#### NOTICE

Running the engine with low oil pressure can cause serious mechanical damage almost immediately.

## If the Charging System Indicator Comes On



### ■ Reasons for the indicator to come on

Comes on when the battery is not being charged.

### ■ What to do when the indicator comes on

Turn off the cooling system\*/climate control system\*, rear demister, and other electrical systems, and immediately contact a dealer for repairs.

### ⚠ If the Charging System Indicator Comes On

If you need to stop temporarily, do not turn off the engine. Restarting the engine may rapidly discharge the battery.



## If the Malfunction Indicator Lamp Comes On or Blinks



### Reasons for the indicator lamp to come on or blink

- Comes on when there is a problem with the engine emissions control system.

#### Petrol models

- Blinks when engine misfiring is detected.

#### Diesel models

- Comes on when air may have entered the fuel system.

### What to do when the indicator lamp comes on

Avoid high speeds and immediately get your vehicle inspected at a dealer.

#### Petrol models

### What to do when the indicator lamp blinks

Park the vehicle in a safe place with no flammable items and wait at least 10 minutes or more with the engine stopped until it cools.

### If the Malfunction Indicator Lamp Comes On or Blinks

#### NOTICE

If you drive with the malfunction indicator lamp on, the emissions control system and the engine could be damaged.

#### Petrol models

If the malfunction indicator lamp blinks again when restarting the engine, drive to the nearest dealer at 50 km/h or less. Have your vehicle inspected.

## If the Brake System Indicator (Red) Comes On



### Reasons for the indicator to come on

- The brake fluid is low.
- There is a malfunction in the brake system.

### What to do when the indicator comes on while driving

Depress the brake pedal lightly to check pedal pressure.

- If normal, check the brake fluid level the next time you stop.
- If abnormal, take immediate action. If necessary, downshift the transmission to slow the vehicle using engine braking.

### If the Brake System Indicator (Red) Comes On

Have your vehicle repaired immediately.

It is dangerous to drive with low brake fluid. If there is no resistance from the brake pedal, stop immediately in a safe place. If necessary downshift the gears.

If the brake system indicator (red) and **ABS** indicator come on simultaneously, the electronic brake distribution system is not working. This can result in vehicle instability under sudden braking. Have your vehicle inspected by a dealer immediately.

## If the Electric Power Steering (EPS) System Indicator Comes On

---



### ■ Reasons for the indicator to come on

- Comes on when there is a problem with the EPS system.
- If you depress the accelerator pedal repeatedly to increase the engine speed while the engine is idling, the indicator comes on, and sometimes the steering wheel becomes harder to operate.

### ■ What to do when the indicator comes on

Stop the vehicle in a safe place and restart the engine.

If the indicator comes on and stays on, immediately have your vehicle inspected by a dealer.

Indian, Bhutanese, Nepalese and Sri Lankan models

## If the Low Tyre Pressure/Deflation Warning System Indicator Comes On or Blinks



### ■ Reasons for the indicator to come on or blink

A tyre pressure is significantly low, or the deflation warning system has not been calibrated. If there is a problem with the deflation warning system, the indicator blinks for about one minute, and then stays on. If the compact spare tyre\* is installed, the indicator will either come on or it will first blink for about one minute, then stay on.

### ■ What to do when the indicator comes on

Drive carefully and avoid abrupt cornering and hard braking. Stop your vehicle in a safe place. Check the tyre pressure and adjust the pressure to the specified level. The specified tyre pressure is on a label on the driver side doorjamb.

- ▶ Calibrate the deflation warning system after the tyre pressure is adjusted.

#### 🔧 Deflation Warning System Initialisation P. 232

If the compact spare tyre\* causes the indicator to come on, change the tyre to a full-size tyre. The indicator goes off after calibrating the deflation warning system.

### ■ What to do when the indicator blinks, then remains on

Have the tyre inspected by a dealer as soon as possible. If the compact spare tyre\* causes the indicator first blink, and then stays on, change the tyre to a full-size tyre.

The indicator goes off after calibrating the deflation warning system.

▶▶ If the Low Tyre Pressure/Deflation Warning System Indicator Comes On or Blinks

### NOTICE

Driving on an extremely underinflated tyre can cause it to overheat. An overheated tyre can fail. Always inflate your tyres to the prescribed level.

\* Not available on all models

Diesel models with information display

## If the PGM-FI Indicator Comes On

**PGM-FI**

### ■ Reasons for the indicator to come on while the engine is running

There is a problem with the engine control system.

### ■ What to do when the indicator to come on for the first time

1. Stop in a safe place.
2. Stop the engine for about 30 seconds, and restart the engine.
3. Repeat step 2 for at least three times.

### ■ What to do when the indicator comes on repeatedly

Avoid full-throttle acceleration and high speed driving. Have your vehicle checked by a dealer.

▶▶ If the PGM-FI Indicator Comes On

### NOTICE

Continuously driving with this indicator on can damage the emissions controls and engine. Those repairs may not be covered by your vehicle's warranties.

## If the PGM-FI Symbol Appears

Diesel models with driver information interface

**PGM-FI**

Engine Control  
System Problem.  
Power May Be  
Reduced.

### ■ Reasons for the symbol to appear while the engine is running

There is a problem with the engine control system.

### ■ What to do when the symbol appears for the first time

1. Stop in a safe place.
2. Stop the engine for about 30 seconds, and restart the engine.
3. Repeat step 2 for at least three times.

### ■ What to do when the symbol appears repeatedly

Avoid full-throttle acceleration and high speed driving. Have your vehicle checked by a dealer.

▶▶ If the PGM-FI Symbol Appears

#### NOTICE

Continuously driving with this symbol on can damage the emissions controls and engine. Those repairs may not be covered by your vehicle's warranties.

## Fuse Locations

If any electrical devices are not working, set the power mode to VEHICLE OFF (LOCK) and check to see if any applicable fuse is blown.

There are two fuse boxes in the engine compartment.

### ■ Engine Compartment Fuse Box (Type A)

Located near the ⊕ terminal on the battery.

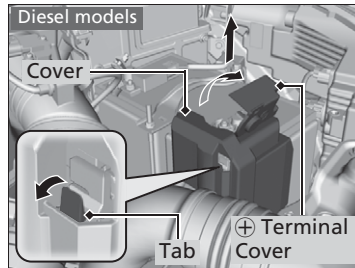
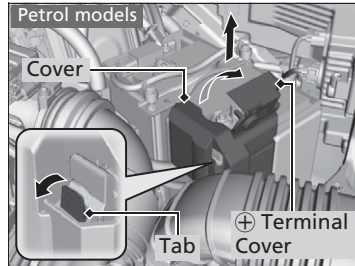

1. Open the ⊕ terminal cover.
2. Remove the cover by pulling the tab as shown.  
Replacement of engine compartment fuses should be done by a dealer.

## ■ Circuit protected and fuse rating

### Petrol models

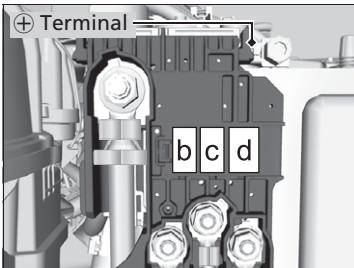
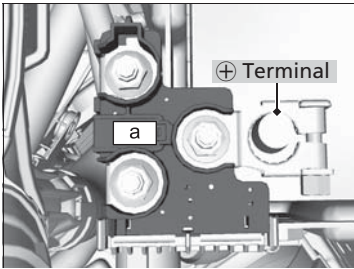

	Circuit Protected	Amps
a	MAIN	100 A
b	RB MAIN 1	70 A
c	RB MAIN 2	80 A
d	CAP MAIN	70 A

### Diesel models

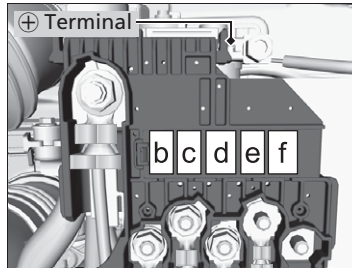
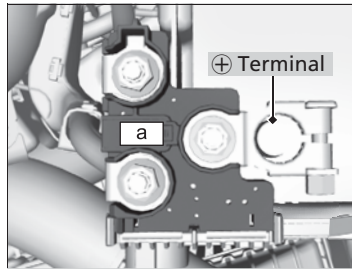

	Circuit Protected	Amps
a	MAIN	100 A
b	MAIN 1	70 A
c	RB MAIN 2	80 A
d	EPS	70 A
e	GLOW	60 A
f	FFV	70 A

## ■ Engine Compartment Fuse Box (Type B)

Models with fuse number-stamped on the cover

Located in the back of the engine compartment on the left side. Push the tabs to open the box.

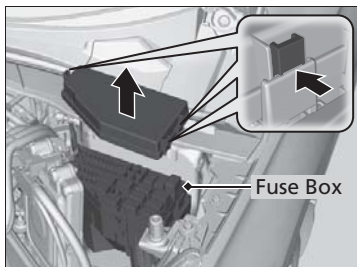

Fuse locations are shown on the fuse box cover.

Locate the fuse in question by the fuse number and box cover mark.

## ■ Circuit protected and fuse rating

		Circuit Protected	Amps
1		Wiper	30 A
2		–	(20 A)
3		Hazard	10 A
4		Stop	10 A
5	–	–	–
6	–	–	–
7	–	–	–
8		IGP	15 A
9		IG Coil	15 A
10		DBW	15 A
11		ABS/VSA MTR	40 A
12		Main Fan	30 A
13		ST Magnetic SW	30 A
14		MG Clutch	7.5 A
15		Battery Sensor	7.5 A

		Circuit Protected	Amps
16		Transmission Control Unit*	(10 A)
17		Back Up FI-ECU	10 A
18		Horn	10 A
19		Front Fog Light*	(10 A)
20		Front Fog Light*	(15 A)
21		Back Up Main	(15 A)
22		Back Up	10 A
23		Sub Fan	(30 A)
24		ABS/VSA FSR	30 A
25		IGP2 Sub	7.5 A
26		IGPS (LAF)	10 A
27	–	–	–
28	–	–	–
29	–	–	–
30		–	(30 A)
31		Starter DIAG	(7.5 A)
32	–	–	–
33	–	–	–



Models without fuse number-stamped on the cover

Located in the back side of the engine compartment on the left side.  
Push the tabs to open the box.

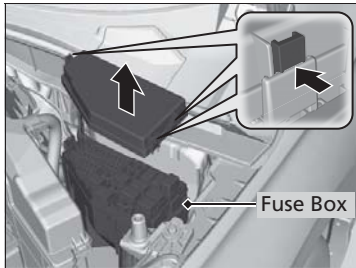

Fuse locations are shown on the image below.

Locate the fuse in question by the fuse number in the image and chart.

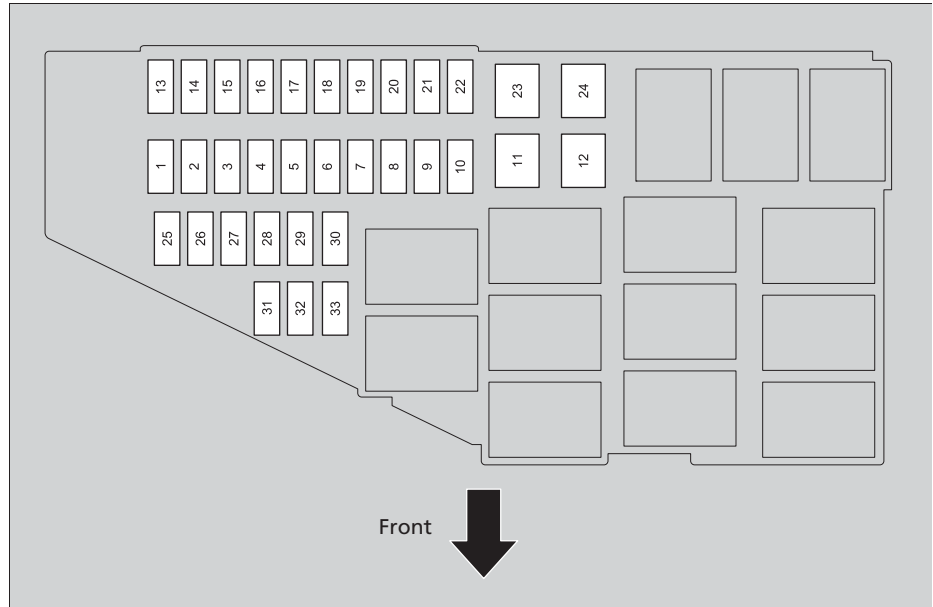

■ **Circuit protected and fuse rating**

	Circuit Protected	Amps
1	Wiper	30 A
2	–	–
3	Hazard	10 A
4	Stop	10 A
5	–	–
6	LAF* <sup>2</sup>	(7.5 A)
7	–	–
8	IGP	(15 A) <sup>*1</sup> (20 A) <sup>*2</sup>
9	IG Coil <sup>*1</sup>	15 A
10	DBW <sup>*1</sup>	15 A
11	ABS/VSA MTR	40 A
12	MAIN FAN	30 A
13	ST Magnetic SW	30 A
14	MG Clutch	7.5 A
15	Battery Sensor	7.5 A
16	Transmission Control Unit	(10 A) <sup>*1</sup> (15 A) <sup>*2</sup>
17	Back Up FI-ECU	10 A
18	Horn	10 A
19	Front Fog Light*	(10 A)
20	Front Fog Light*	(15 A)

	Circuit Protected	Amps
21	Back Up Main	15 A
22	Back Up	10 A
23	Sub Fan	30 A
24	ABS/VSA FSR	30 A
25	IGP2 Sub <sup>*1</sup>	(7.5 A)
26	IGPS (LAF) <sup>*1</sup>	(10 A)
27	–	–
28	–	–
29	–	–
30	–	–
31	Starter DIAG	(7.5 A)
32	–	–
33	–	–

\*1: Petrol models

\*2: Diesel models

## Driver's Side Interior Fuse Box

### Models with interior fuse box label

Located under the dashboard.

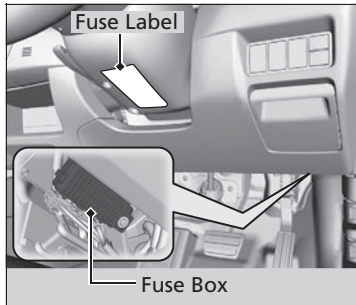











Fuse locations are shown on the label. Locate the fuse in question by the fuse number and label number.

### ■ Circuit protected and fuse rating

		Circuit Protected	Amps
1		Accessory	7.5 A
2		Accessory Key Lock	7.5 A
3		–	(10 A)
4		–	(7.5 A)
5		Option	10 A
6		Option2	10 A
7		Meter	10 A
8		Fuel Pump	15 A
9		A/C	10 A
10		Rear Accessory Socket	(20 A)
11		Mon	5 A
12		Right Side Door Lock	10 A
13		Left Side Door Unlock	10 A
14		Rear Left Power Window	20 A
15		Front Passenger's Power Window	20 A

		Circuit Protected	Amps
16		Door Lock	20 A
17		Transmission Control Unit	(10 A)
18		–	(10 A)
19		–	(20 A)
20		Starter Cut	7.5 A
21		ACG	(10 A)
22		Daytime Running Lights	7.5 A
23		–	(10 A)
24		Option	7.5 A
25		–	(10 A)
26		Right Side Door Unlock	10 A
27		Rear Right Power Window	20 A
28		Driver's Power Window	20 A
29		Front Accessory Socket	20 A

		Circuit Protected	Amps
30		Smart	(10 A)
31		–	(15 A)
32		–	(20 A)
33		–	(20 A)
34		ABS/VSA	10 A
35		SRS	10 A
36		–	(20 A)
37		IMG	(10 A)
38		Left Side Door Lock	10 A
39		–	(10 A)

**Models without interior fuse box label**

Located under the dashboard.

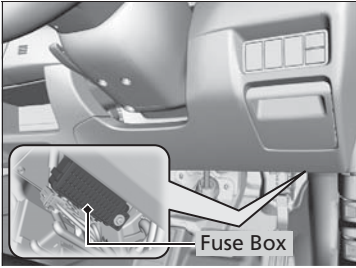

Fuse locations are shown on the image below.

Locate the fuse in question by the fuse number in the image and chart.

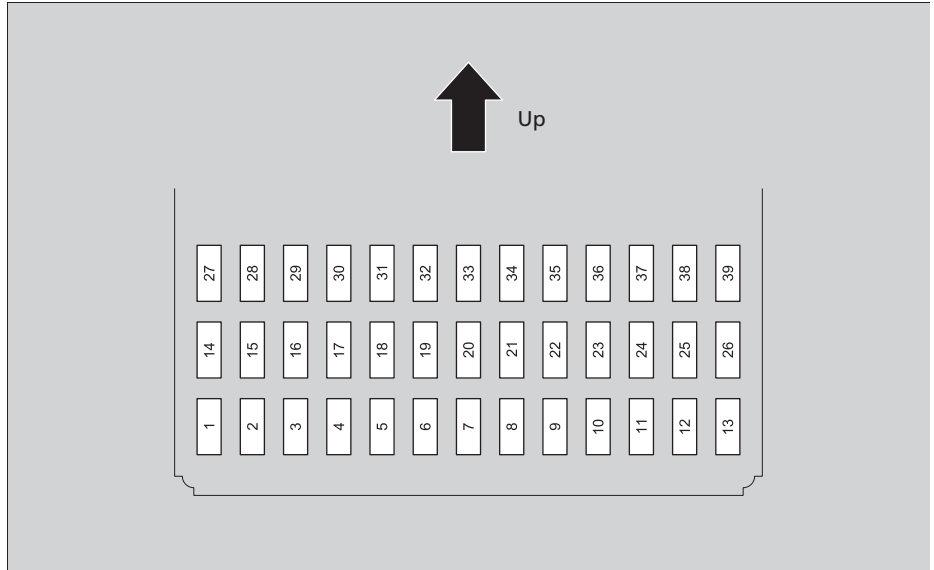

■ **Circuit protected and fuse rating**

	Circuit Protected	Amps
1	Accessory	7.5 A
2	Accessory Key Lock	7.5 A
3	–	–
4	–	–
5	Option	10 A
6	Option2	10 A
7	Meter	10 A
8	Fuel Pump	15 A
9	A/C	10 A
10	Rear Accessory Socket	(20 A)
11	Mon	5 A
12	Right Side Door Lock	10 A
13	Left Side Door Unlock	10 A
14	Rear Left Power Window	20 A
15	Front Passenger's Power Window	20 A
16	Door Lock	20 A
17	Transmission Control Unit	(10 A)
18	–	–
19	Sunroof*	(20 A)
20	Starter Cut	7.5 A

	Circuit Protected	Amps
21	ACG	10 A
22	Daytime Running Lights	7.5 A
23	–	–
24	Option	7.5 A
25	Driver's Door Lock*	(10 A)
26	Right Side Door Unlock	10 A
27	Rear Right Power Window	20 A
28	Driver's Power Window	20 A
29	Front Accessory Socket	20 A
30	Smart	10 A
31	–	–
32	–	–
33	–	–
34	ABS/VSA	10 A
35	SRS	10 A
36	–	–
37	IMG	10 A
38	Left Side Door Lock	10 A
39	Driver's Door Unlock*	(10 A)

## Passenger's Side Interior Fuse Box A

Models with interior fuse box label

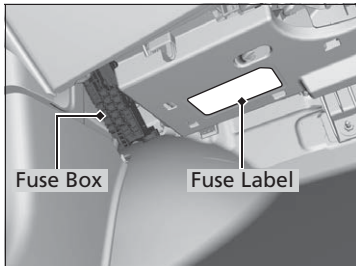

Fuse locations are shown on the label. Locate the fuse in question by the fuse number and label number.

### ■ Circuit protected and fuse rating

		Circuit Protected	Amps
1		Fuse Box Main1*1	60 A
2		IG Main	30 A
3		IG Main 2	30 A
4		Relay Module1	30 A
5		Relay Module2	30 A
6		Fuse Box Main2	40 A
7		–	(40 A)
8		–	–
9		–	(40 A)
10		DC/DC1	(30 A)
11		–	–
12		Heater Motor	30 A
13		Rear Demister	30 A
14		SRS	10 A
15		–	(10 A)

		Circuit Protected	Amps
16		–	(10 A)
17		–	(10 A)
18		ACC Socket (Console2)*	(20 A)
19		–	–
20		–	–
21		Washer	15 A
22		–	–
23		–	(15 A)
24		–	–
25		–	–

\*1: Replacement of this fuses should be done by a dealer.

\* Not available on all models

Models without interior fuse box label

Located under the dashboard.

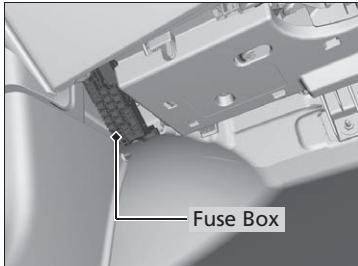

Fuse locations are shown on the image below.

Locate the fuse in question by the fuse number in the image and chart.

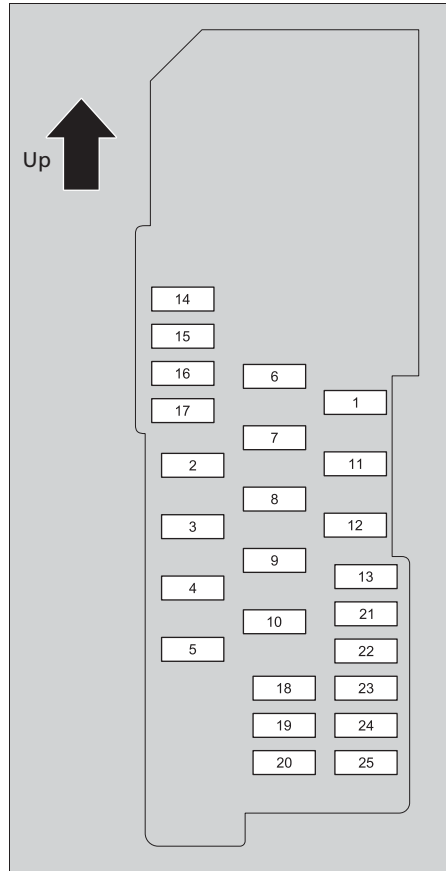



■ **Circuit protected and fuse rating**

	Circuit Protected	Amps
1	Fuse Box Main1*1	60 A
2	IG Main	30 A
3	IG Main 2	30 A
4	Relay Module1	30 A
5	Relay Module2	30 A
6	Fuse Box Main2	40 A
7	Fuse Box Option*	(40 A)
8	–	–
9	–	–
10	DC/DC1	(30 A)
11	–	–
12	Heater Motor	30 A
13	Rear Demister*	(30 A)* (40 A)*
14	SRS	10 A
15	–	–

	Circuit Protected	Amps
16	–	–
17	–	–
18	ACC Socket (Console2)*	(20 A)
19	–	–
20	–	–
21	Washer	15 A
22	–	–
23	–	–
24	–	–
25	–	–

\*1: Replacement of this fuses should be done by a dealer.

\* Not available on all models

Petrol models

**Passenger's Side Interior Fuse Box B**

Located under the dashboard.

1. Open the glove box.

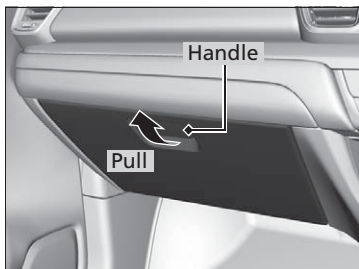

2. Disengage the two tabs by pushing on each side panel.
3. Pivot the glove box out of the way.

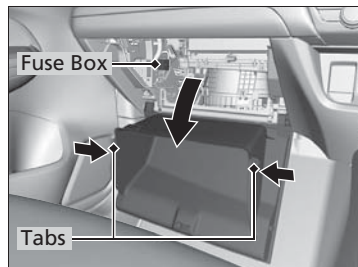

Fuse locations are shown on the label. Locate the fuse in question by the fuse number and label number.

**■ Circuit protected and fuse rating**

		Circuit Protected	Amps
1		ACC Cut VST	(7.5 A)
2		-	-
3		VST IG1-1	(7.5 A)
4		Back Up 2 Main	(15 A)

## Inspecting and Changing Fuses

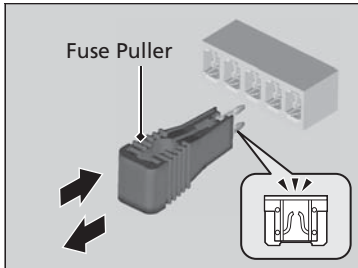
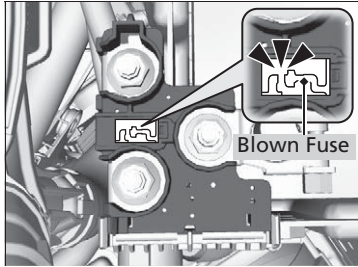

1. Set the power mode to VEHICLE OFF (LOCK). Turn headlights and all accessories off.
2. Remove the fuse box cover.
3. Check the large fuses in the engine compartment.
  - If the fuse is blown, have it replaced by a dealer.
4. Inspect the small fuses in the engine compartment and the vehicle interior.
  - If there is a blown fuse, remove it with the fuse puller and replace it with a new one.
5. Inspect the small fuses in the vehicle interior.
  - If there is a burned out fuse, remove it with the fuse puller and replace it with a new one.

### ► Inspecting and Changing Fuses

#### NOTICE

Replacing a fuse with one that has a higher rating greatly increases the chances of damaging the electrical system.

Replace fuse with a spare fuse of the same specified amperage.

#### Models with fuse label

Use the charts to locate the fuse in question and confirm the specified amperage on the fuse label.

#### Models without fuse label

Use the charts to locate the fuse in question and confirm the specified amperage.

➤ **Fuse Locations** P. 348, 350, 353

There is a fuse puller on the type B engine compartment fuse box cover.

Call a professional towing service if you need to tow your vehicle.

## ■ Flat bed equipment

The operator loads your vehicle on the back of a truck.

**This is the best way to transport your vehicle.**

## ■ Wheel lift equipment

The tow truck uses two pivoting arms that go under the front tyres and lift them off the ground. The rear tyres remain on the ground. **This is an acceptable way to tow your vehicle.**

## » Emergency Towing

### NOTICE

Trying to lift or tow your vehicle by the bumpers will cause serious damage. The bumpers are not designed to support the vehicle's weight.

### NOTICE

Improper towing such as towing behind a motorhome or other motor vehicle can damage the transmission.

Never tow your vehicle with just a rope or chain. It is very dangerous since ropes or chains may shift from side to side or break.

# Information

This chapter includes your vehicle's specifications, locations of identification numbers, and other information required by regulation.

<b>Specifications</b> .....	364
<b>Identification Numbers</b>	
Vehicle Identification Number (VIN), Engine Number and Transmission Number .....	368
<b>Devices that Emit Radio Waves*</b> .....	370
<b>TCU Open Source Licence*</b>	
Free/Open Source Software Information ..	371

\* Not available on all models

## ■ Vehicle Specifications

Model	City* <sup>1</sup> Ballade* <sup>2</sup>	
Curb Weight	1,107-1,217 kg <sup>3</sup> 1,112-1,153 kg <sup>4</sup> 1,122-1,132 kg <sup>5</sup>	
Maximum Permissible Weight	1,580 kg <sup>6</sup> 1,650 kg <sup>7</sup>	
Maximum Permissible Axle Weight	Front	850 kg <sup>6</sup> 920 kg <sup>7</sup>
	Rear	735 kg

\*1: Models with emblem of CITY

\*2: Models with emblem of BALLADE

\*3: Indian, Bhutanese, Nepalese and Sri Lankan models

\*4: African models

\*5: Malaysian models

\*6: Petrol models

\*7: Diesel models

## ■ Engine Specifications

Type	Water-cooled in-line 4-cylinder DOHC	
Bore x Stroke	73.0 x 89.5 mm <sup>1</sup> 76.0 x 82.5 mm <sup>2</sup>	
Displacement	1,498 cm <sup>3</sup>	
Compression Ratio	10.6 : 1 <sup>1</sup> 16.0 : 1 <sup>2</sup>	
Spark Plugs <sup>1</sup>	NGK	DILZKAR7C11H
	DENSO	DXE22HCR11H

\*1: Petrol models

\*2: Diesel models

## ■ Fuel

Type	<b>Petrol models</b>
	Unleaded petrol, research octane number 90 or higher <sup>1</sup>
Fuel Tank Capacity	<b>Diesel models</b>
	Automotive Diesel Fuel

\*1: Indonesian models

\*2: Except Indonesian models

## ■ Battery

Capacity	<b>Petrol models</b>
	27AH(5)30AH(20) <sup>*1</sup> 28AH(5)35AH(20) <sup>*2</sup>
	<b>Diesel models</b>
	38AH(5)47AH(20)

\*1: Except African models

\*2: African models

## ■ Washer Fluid

Tank Capacity	1.8 L
---------------	-------

### ■ Light Bulbs

Headlights (Low Beam)	55 W (H7) <sup>*1</sup> LED <sup>*2</sup>
Headlights (High Beam)	60 W (HB3) <sup>*1</sup> LED <sup>*2</sup>
Fog Lights*	19 W (H16) <sup>*3, *4</sup> 35 W (H8) <sup>*5</sup> LED <sup>*6</sup>
Front Turn Signal Lights	21 W (Amber) <sup>*1</sup> LED <sup>*2</sup>
Position/Daytime Running Lights	LED
Side Turn Signal Lights (on Front Fender)*	5 W (Amber)
Side Turn Signal Lights (on Door Mirror)*	LED
Brake Lights	LED
Taillights/Rear Side Marker Lights	LED
Taillights	LED
Rear Turn Signal Lights	21 W (Amber)
Back-Up Lights	16 W
High-Mount Brake Light	LED
Rear Licence Plate Lights	5 W
Interior Lights	
Front Map Lights	8W <sup>*7, *8, *9, *10</sup> LED <sup>*11, *12</sup>
Rear Map Lights*	8W <sup>*7</sup> LED <sup>*11, *13</sup>
Ambient Light*	LED
Ceiling Light*	8W <sup>*8, *9, *10</sup> LED <sup>*4</sup>
Centre Pocket Light	LED
Boot Light	5 W
Foot Lights*	LED

- \*1: Models with halogen headlights
- \*2: Models with LED headlights
- \*3: Indian, Bhutanese, Nepalese and Sri Lankan models with halogen headlights
- \*4: African models with halogen headlights
- \*5: EX models
- \*6: Models with LED fog lights
- \*7: VX and VX-D models
- \*8: V and V-D models
- \*9: Latin American models
- \*10: Malaysian, Bangladeshi, Brunei, Singaporean and Indonesian models
- \*11: ZX and ZX-D models
- \*12: African models
- \*13: African models with sunroof

### ■ Air Conditioning

Refrigerant Type	HFC-134a (R-134a)
Charge Quantity	355 - 405 g <sup>*1</sup> 395 - 445 g <sup>*2</sup>

- \*1: Diesel models
- \*2: Petrol models

### ■ Brake/Clutch\* Fluid

Specified	Brake Fluid with DOT 3 or DOT 4
-----------	---------------------------------

### ■ Manual Transmission Fluid\*

Specified	Honda MTF	
Capacity	Change	1.4 L <sup>*1</sup> 1.9 L <sup>*2</sup>

- \*1: Petrol models
- \*2: Diesel models

### ■ Continuously Variable Transmission Fluid\*

Specified	Honda HCF-2	
Capacity	Change	2.8 L

\* Not available on all models

### ■ Engine Oil

Recommended	<b>Petrol models</b>	
	Honda Engine OIL #1.0 Honda Green OIL Honda Genuine Motor Oil 0W-16, 0W-20, 5W-30 ACEA A5/B5, API service SM or higher grade 0W-16, 0W-20, 5W-30	
Capacity	<b>Diesel models</b>	
	Honda Genuine Diesel Oil #2.0 ACEA C2/C3 0W-30, 5W-30	
Change	3.1 L <sup>*1</sup>	
	4.0 L <sup>*2</sup>	
Change including filter	3.3 L <sup>*1</sup>	
	4.4 L <sup>*2</sup>	

\*1: Petrol models

\*2: Diesel models

### ■ Engine Coolant

Specified	Honda All Season Antifreeze/Coolant Type 2
Ratio	50/50 with distilled water
Capacity <sup>*1, *2</sup>	<b>Petrol models</b>
	3.65 L <sup>15</sup> (change including the remaining 0.42 L in the reserve tank) 3.79 L <sup>16</sup> (change including the remaining 0.42 L in the reserve tank)
Capacity <sup>*3, *4</sup>	<b>Diesel models</b>
	3.95 L (change including the remaining 0.47 L in the reserve tank) 3.53 L <sup>15</sup> (change including the remaining 0.42 L in the reserve tank) 3.67 L <sup>16</sup> (change including the remaining 0.42 L in the reserve tank)

\*1: African models

\*2: Indian, Bhutanese, Nepalese and Sri Lankan models

\*3: Southeast Asian and Latin American models

\*4: Bangladeshi models

\*5: Manual Transmission models

\*6: Continuously Variable Transmission models

### ■ Tyre

Regular	Size <sup>*1</sup>	185/60R15 84H 185/55R16 83H 185/55R16 87H
	Pressure	See the label on driver's doorjamb
Compact Spare <sup>*</sup>	Size <sup>*1</sup>	T135/80D15 99M T135/80D15 100M
	Pressure	See the label on driver's doorjamb
Temporary Spare <sup>*</sup>	Size	175/65R15 84T
	Pressure	See the label on driver's doorjamb
Spare <sup>*</sup> (Full-size tyre)	Size <sup>*1</sup>	185/55R16 83H 185/55R16 87H
	Pressure	Same as the regular tyre. See the label on driver's doorjamb.
Wheel Size	Regular	15 x 6J <sup>*2</sup> 16 x 6J <sup>*3</sup>
	Compact Spare <sup>*</sup>	15 x 4T
	Temporary Spare <sup>*</sup>	15 x 5 1/2J
	Full-size Spare <sup>*</sup>	16 x 6J

\*1: Original tyre size is mentioned on the tyre information label on the driver's doorjamb.

\*2: Models with 15 inch wheel

\*3: Models with 16 inch wheel

#### Indian model only

The tyres fitted in the vehicles meet the requirement of the BIS and they comply with the requirements under the central motor vehicles rules (CMVR), 1989.



## ■ Brake

Type	Power assisted
Front	Ventilated disc
Rear	Drum
Parking	Mechanical

## ■ Vehicle Dimensions

Length		4,549 mm <sup>*1</sup>
		4,553 mm <sup>*2</sup>
Width		1,748 mm
Height		1,467 mm <sup>*2</sup>
		1,489 mm <sup>*1</sup>
Wheelbase		2,600 mm
Track	Front	1,495 mm <sup>*2</sup>
		1,496 mm <sup>*1</sup>
	Rear	1,483 mm <sup>*2</sup>
		1,484 mm <sup>*1</sup>

\*1: Indian, Bhutanese, Nepalese and Sri Lankan models

\*2: Malaysian models

## Vehicle Identification Number (VIN), Engine Number and Transmission Number

Your vehicle has a 17-digit vehicle identification number (VIN) used to register your vehicle for warranty purposes, and for licensing and insuring your vehicle. The locations of your vehicle's VIN, engine number and transmission number are shown as follows.

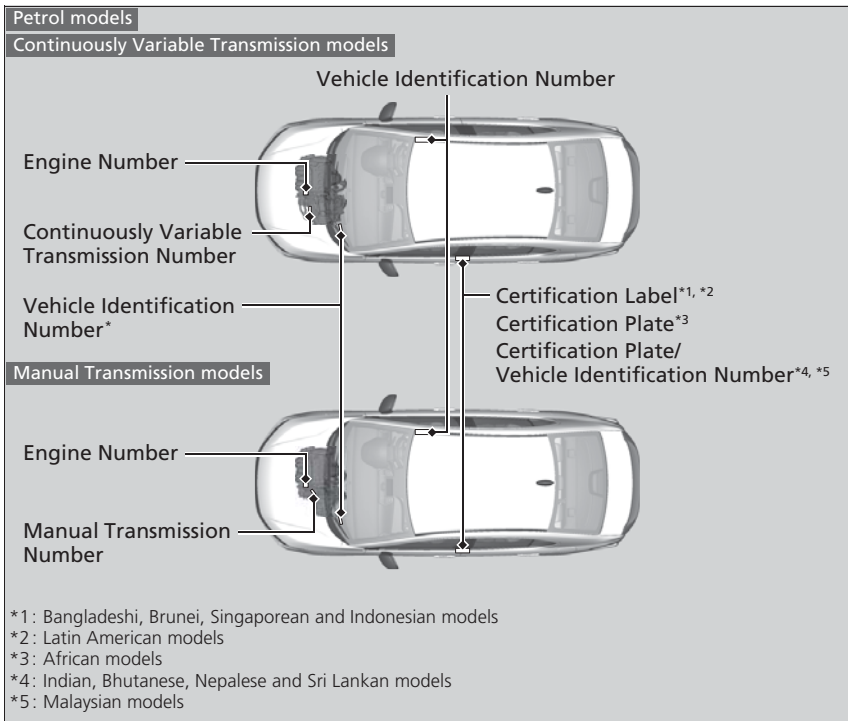

### Vehicle Identification Number (VIN), Engine Number and Transmission Number

The interior vehicle identification number (VIN) is located under the cover.

**Southeast Asian and Latin American models**  
**Bangladeshi models**



**African models**  
**Indian, Bhutanese, Nepalese and Sri Lankan models**

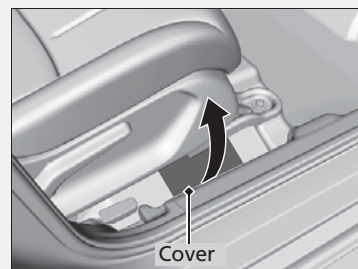

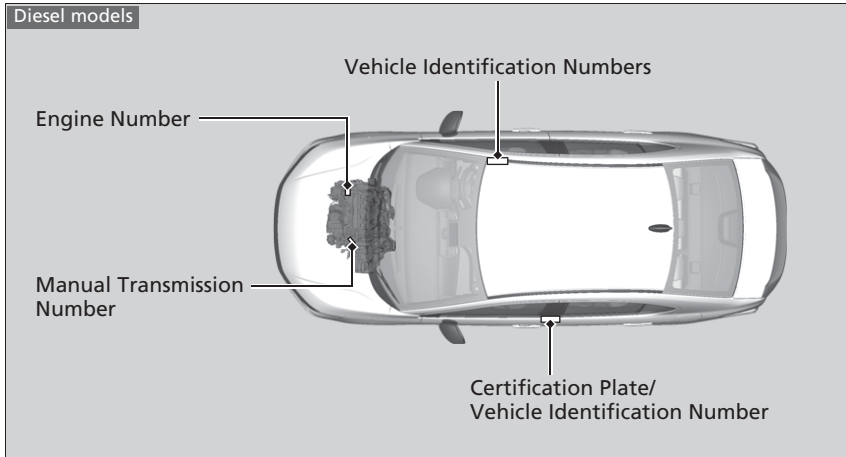

# Devices that Emit Radio Waves\*

The following products and systems on your vehicle emit radio waves when in operation.

## Keyless Access System\*

Zambian models

FOB:



Botswanan models

FOB:



Singaporean models

FOB:



## Free/Open Source Software Information

---

This product contains Free/Open Source Software(FOSS).

The licence information and/or the source code of such FOSS can be found at the following URL.

*<https://www.denso.com/global/en/opensource/tcu/honda/>*

## Numbers

7-Speed Manual Shift Mode ..... 217

## A

ABS (Anti-lock Brake System)..... 237

Accessories and Modifications..... 314

Accessory Power Sockets ..... 189

### Adding

Coolant ..... 271

Engine Oil..... 270

Washer..... 276

Additives, Engine Oil ..... 266, 267, 268

### Adjusting

Armrest ..... 182

Front Seats ..... 175

Head Restraints..... 178

Headlights ..... 164

Mirrors ..... 172

Rear Seats..... 181

Steering Wheel ..... 171

Temperature..... 105

Agile Handling Assist..... 230

### Air Conditioning System (Climate Control

System) ..... 194

Changing the Mode ..... 194

Defrosting the Windscreen and

Windows ..... 196

Dust and Pollen Filter..... 307

Recirculation/Fresh Air Mode ..... 194, 195

Sensors..... 197

Using Automatic Climate Control..... 194

### Air Conditioning System (Cooling

System) ..... 191

Cooling ..... 192

Defrosting the Windscreen and

Windows ..... 193

Dust and Pollen Filter..... 307

Air Pressure..... 366

Airbags ..... 44

After a Collision ..... 47

Airbag Care..... 53

Event Data Recorder..... 1

Front Airbags (SRS)..... 46

Indicator..... 52, 94

Sensors ..... 44

Side Airbag ..... 49

Side Curtain Airbag ..... 51

Anti-lock Brake System (ABS) ..... 237

Indicator..... 94

Armrest ..... 182

Auto Door Locking/Unlocking ..... 139

Average Fuel Economy ..... 107, 111

Average Speed ..... 113

## B

Battery ..... 303

Charging System Indicator..... 91, 342

Jump Starting..... 333

Maintenance (Checking the Battery)..... 303

Belts (Seat) ..... 33

Beverage Holders ..... 186

Booster Seats (For Children) ..... 82

Boot ..... 146

Lid ..... 146

Light Bulb ..... 293

Brake System ..... 235

Anti-lock Brake System (ABS) ..... 237

Brake Assist System..... 238

Fluid ..... 275

Foot Brake ..... 236

Indicator ..... 90, 343

Parking Brake..... 235

Brightness Control (Instrument Panel) ... 168

Bulb Replacement ..... 280

Back-Up Lights ..... 288

Boot Light..... 293

Brake Lights ..... 286

Ceiling Light ..... 291

Fog Lights ..... 283

Front Turn Signal Lights ..... 282

Headlights ..... 280

High-Mount Brake Light..... 290

Map Lights..... 291, 292

Position/Daytime Running Lights ..... 282

Rear Licence Plate Lights ..... 289

Rear Map Lights..... 292

Rear Side Marker Lights ..... 286

Rear Turn Signal Lights..... 286

Side Turn Signal Lights ..... 285

Taillights ..... 286, 288

Bulb Specifications ..... 365

## C

Carbon Monoxide Gas .....	84
Carrying Luggage .....	203, 204
Certification Label .....	368
Changing Bulbs .....	280
Charging System Indicator .....	91, 342
Child Restraint System .....	54
Booster Seats .....	82
Child Restraint System for Infants.....	58
Child Restraint System for Small Children..	60
Installing a Child Restraint System with a Lap/Shoulder Seat Belt .....	77
Installing a Lower Anchorage-Compatible Child Restraint System.....	73
Larger Children .....	81
Rearward Facing Child Restraint System ....	58
Selecting a Child Restraint System .....	61
Using Tether .....	79
Child Safety .....	54
Childproof Door Locks .....	138
Cleaning the Exterior .....	311
Cleaning the Interior .....	309
Climate Control System .....	194
Changing the Mode.....	194
Defrosting the Windscreen and Windows .....	196
Dust and Pollen Filter .....	307
Recirculation/Fresh Air Mode.....	194, 195
Sensors .....	197
Using Automatic Climate Control.....	194
Clock .....	124

Clutch Fluid .....	275
Coat Hook .....	188
Compact Spare Tyre .....	319, 366
Console Compartment .....	185
Continuously Variable Transmission .....	214
Creeping .....	214
Fluid .....	274
Kickdown .....	214
Operating the Shift Lever .....	18, 215, 216
Shift Lever Does Not Move .....	337
Shifting .....	215
Controls .....	123
Coolant (Engine).....	271
Adding the Coolant.....	273
Checking the Coolant.....	271
High Temperature Indicator .....	94
Low Temperature Indicator .....	94
Overheating .....	338
Cooling System .....	191
Cooling .....	192
Defrosting the Windscreen and Windows .....	193
Dust and Pollen Filter .....	307
Creeping (Continuously Variable Transmission) .....	214
Cruise Control .....	222
Indicator .....	98
Cup Holders .....	186
Customizing the Auto Door Locking/ Unlocking Setting .....	140

## D

Daytime Running Lights .....	165
Dead Battery.....	333
Deflation Warning System.....	231
Defrosting the Windscreen and Windows .....	193, 196
Devices that Emit Radio Waves .....	370
Diesel.....	20, 247
Fuel Economy and CO <sub>2</sub> Emissions .....	249
Information .....	247
Refueling.....	247
Diesel Particulate Filter (DPF) .....	277
Dimming .....	
Headlights.....	161
Dipstick (Engine Oil).....	268
Directional Signals (Turn Signals).....	160
Door Mirrors .....	173
Doors .....	126
Auto Door Locking .....	139
Auto Door Unlocking .....	139
Door/Boot Open Indicator .....	31, 95
Keys .....	126
Locking/Unlocking the Doors from the Inside .....	135
Locking/Unlocking the Doors from the Outside .....	128
Lockout Prevention System.....	134
Driver Information Interface .....	108
Driver's Side Pocket.....	188

Driving .....	201
Braking .....	235
Continuously Variable Transmission .....	214
Cruise Control .....	222
Shifting Gear .....	215, 219
Starting the Engine .....	206
Dust and Pollen Filter .....	307

## E

Eco Assist System .....	9
ECON Mode .....	221
Elapsed Time .....	113
Electric Power Steering (EPS) System	
Indicator .....	96, 344
Emergency .....	362
Emergency Stop Signal .....	239
Engine	
Coolant .....	271
Jump Starting .....	333
Number .....	368
Oil .....	266, 267
Starting .....	206
Switch Buzzer .....	157
Engine Coolant .....	271
Adding the Coolant .....	273
Checking the Coolant .....	271
High Temperature Indicator .....	94
Low Temperature Indicator .....	94
Overheating .....	338

Engine Oil .....	266, 267
Adding .....	270
Checking .....	268
Low Oil Pressure Indicator .....	91, 340
Recommended Engine Oil .....	266, 267
ENGINE START/STOP Button .....	157
EPS (Electric Power Steering) System .....	96
Exhaust Hazard (Carbon Monoxide) .....	84
Exterior Care (Cleaning) .....	311
Exterior Mirrors .....	173

## F

Features .....	199
Filter	
Dust and Pollen .....	307
Flat Tyre .....	319
Fluids	
Brake .....	275
Clutch .....	275
Continuously Variable Transmission .....	274
Engine Coolant .....	271
Manual Transmission .....	274
Windscreen Washer .....	276
Fog Light Indicator .....	96
Folding Down the Rear Seats .....	181
Foot Brake .....	236
Front Airbags (SRS) .....	46
Front Seats .....	176
Adjusting .....	176

Fuel .....	20, 246
Fuel Economy and CO <sub>2</sub> Emissions .....	249
Gauge .....	104
Instant Fuel Economy .....	104, 111
Low Fuel Indicator .....	93
Range .....	107, 111
Recommendation .....	246, 247
Refueling .....	246, 247
Fuel Economy and CO <sub>2</sub> Emissions .....	249
Fuel Fill Cap .....	20, 248
Fuel Fill Door .....	20, 248
Fuses .....	348
Inspecting and Changing .....	361
Locations .....	348, 350, 353, 357, 360

## G

Gauges .....	104
Gear Shift Lever Positions	
Continuously Variable Transmission .....	215
Manual Transmission .....	219
Glass (care) .....	310, 312
Glove Box .....	185
G-Meter .....	114

## H

Halogen Bulbs .....	280, 281, 283
Hazard Warning Button .....	4
Head Restraints .....	178



<b>Headlights</b> .....	161
Adjuster .....	164
Aiming .....	280
Dimming .....	161
Operating .....	161
<b>High-Beam Indicator</b> .....	96

## I

<b>Identification Numbers</b> .....	368
Engine and Transmission .....	368
Vehicle Identification .....	368

## Illumination Control

Knob .....	168
------------	-----

<b>Immobilizer System</b> .....	149
Indicator .....	97

## Indicators

ABS (Anti-lock Brake System) .....	94
Brake System Indicator .....	90
Charging System .....	91
CRUISE CONTROL .....	98, 224
CRUISE MAIN .....	98, 222, 224
Diesel Particulate Filter (DPF) Indicator .....	101
Door and Boot Open .....	95
ECO .....	98
ECON Mode .....	98
Electric Power Steering (EPS) System .....	96
Fog Light .....	96
Glow Plugs Indicator .....	102
High Temperature .....	94
High-Beam .....	96

Immobilizer System .....	97
KEY BATT .....	103
Keyless Access System .....	98
Light Control .....	97
Lights On .....	96
Low Fuel .....	93
Low Oil Pressure .....	91
Low Temperature .....	94
Low Tyre Pressure/Deflation Warning System .....	100
M (7-speed manual shift mode) Indicator/Shift .....	92
Malfunction Indicator Lamp .....	91
NO KEY .....	103
Parking Brake and Brake System .....	90
PGM-FI Indicator .....	102
Rear Seat Belt Reminder Indicators .....	93
Rotate Wheel .....	99
Seat Belt Reminder .....	93
Security System Alarm .....	97
Shift Position .....	92
Shift to Park .....	99
Speed Alarm Indicator .....	101
Starter System .....	99
Supplemental Restraint System .....	94
System Message Indicator .....	101
Transmission System .....	92
Turn Signal .....	96
Vehicle Stability Assist (VSA) System .....	95
VSA OFF .....	95, 229
Water in Fuel Indicator .....	102

<b>Information Display</b> .....	106
<b>Instant Fuel Economy</b> .....	104, 111
<b>Instrument Panel</b> .....	87
Brightness Control .....	168
<b>Interior Lights</b> .....	183
<b>Interior Rearview Mirror</b> .....	172

## J

<b>Jack (Wheel Nut Wrench)</b> .....	323
<b>Jump Starting</b> .....	333

## K

<b>Key Number Tag</b> .....	127
<b>Keys</b> .....	126
Lockout Prevention .....	134
Number Tag .....	127
Rear Door Won't Open .....	138
Remote Transmitter .....	128
Types and Functions .....	126
<b>Kickdown (Continuously Variable Transmission)</b> .....	214

## L

<b>Light Switches</b> .....	161
-----------------------------	-----

- Lights** ..... 161, 280  
 Bulb Replacement ..... 280  
 Daytime Running Lights ..... 165  
 Fog Lights ..... 163  
 High-Beam Indicator Light ..... 96  
 Interior ..... 183  
 Lights On Indicator ..... 96  
 Turn Signals ..... 160
- Load Limits** ..... 204
- Locking/Unlocking** ..... 126  
 Auto Door Locking/Unlocking ..... 139  
 Childproof Door Locks ..... 138  
 From Inside ..... 135  
 From Outside ..... 128  
 Keys ..... 126  
 Using a Key ..... 133
- Lockout Prevention System** ..... 134
- Low Battery Charge** ..... 342
- Low Fuel Indicator** ..... 93
- Low Oil Pressure Indicator** ..... 91, 340
- Low Tyre Pressure/Deflation**  
 Warning System Indicator ..... 100, 345
- Lower Anchorages** ..... 73
- Lubricant Specifications Chart** ..... 366
- Luggage (Load Limit)** ..... 204
- M**
- Maintenance** ..... 251  
 Battery ..... 303  
 Brake Fluid ..... 275
- Cleaning ..... 309  
 Climate Control ..... 307  
 Coolant ..... 271  
 Cooling System ..... 307  
 Oil ..... 268  
 Precautions ..... 252  
 Radiator ..... 273  
 Remote Transmitter ..... 306  
 Replacing Light Bulbs ..... 280  
 Safety ..... 253  
 Transmission Fluid ..... 274  
 Tyres ..... 296  
 Under the Bonnet ..... 263
- Malfunction Indicator Lamp** ..... 91, 343
- Manual Transmission** ..... 219  
 Fluid ..... 274  
 Shifting ..... 219
- Map Lights** ..... 184
- Maximum Permissible Weight** ..... 204
- Meters, Gauges** ..... 104
- Mirrors** ..... 172  
 Adjusting ..... 172  
 Door ..... 173  
 Exterior ..... 173  
 Interior Rear View ..... 172
- Modifications (and Accessories)** ..... 314
- N**
- Numbers (Identification)** ..... 368
- O**
- Odometer** ..... 105, 107
- Oil (Engine)** ..... 266, 267  
 Adding ..... 270  
 Checking ..... 268  
 Low Oil Pressure Indicator ..... 90, 91, 340  
 Recommended Engine Oil ..... 266, 267  
 Viscosity ..... 266, 267
- Opening/Closing**  
 Bonnet ..... 265  
 Boot ..... 146  
 Power Windows ..... 151  
 Sunroof ..... 155
- Outside Temperature** ..... 105  
 Adjusting ..... 105
- Overheating** ..... 338
- P**
- Parking Brake** ..... 235
- Parking Brake and Brake System**  
 Indicator ..... 90, 343
- Parking Sensor System** ..... 242
- Passing Indicators** ..... 161
- Petrol** ..... 20, 246  
 Fuel Economy and CO<sub>2</sub> Emissions ..... 249  
 Gauge ..... 104  
 Information ..... 246  
 Instant Fuel Economy ..... 104, 111  
 Low Fuel Indicator ..... 93  
 Refueling ..... 246

PGM-FI Indicators.....	102, 346
PGM-FI Symbol.....	347
Precautions While Driving.....	213
Rain.....	213
Pregnant Women.....	41
Puncture (Tyre).....	319

## R

Radiator.....	273
Rear Demister Button.....	170
Rear Seats (Folding Down).....	181
Rear Sunshade.....	190
Refueling.....	246
Diesel.....	247, 364
Fuel Gauge.....	104
Low Fuel Indicator.....	93
Petrol.....	246, 364
Remote Engine Start.....	209
Remote Transmitter.....	128
Replacement.....	
Battery.....	303
Bulbs.....	280
Fuses.....	348, 350, 353, 357, 360
Tyres.....	319
Wiper Blade Rubber.....	294
Resetting a Trip Meter.....	107, 111

## S

Safe Driving.....	27
-------------------	----

Safety Check.....	31
Safety Labels.....	85
Safety Message.....	0
Seat Belts.....	33
Checking.....	42
Fastening.....	39
Installing a Child Restraint System with a Lap/Shoulder Seat Belt.....	77
Pregnant Women.....	41
Reminder.....	36
Warning Indicator.....	36, 93
Seats.....	175
Adjusting.....	175
Front Seats.....	176
Rear Seats.....	181
Security System.....	149
Immobilizer System Indicator.....	97
Security System Alarm Indicator.....	97
Select Lever.....	215, 219
Selecting a Child Restraint System.....	61
Setting the Clock.....	124
Settings.....	116
Shift Lever.....	215, 219
Operation.....	215, 219
Releasing.....	337
Shift Lever Position Indicator.....	216
Won't Move.....	337
Shifting (Transmission).....	215, 219
Side Airbags.....	49
Side Curtain Airbag.....	51
Spare Tyre.....	319, 366

Spark Plugs.....	364
Specifications.....	364
Specified Fuel.....	246
Speedometer.....	104
SRS Airbags (Airbags).....	46
Starting the Engine.....	206
Does Not Start.....	329
Engine Switch Buzzer.....	157
Jump Starting.....	333
Steering Wheel.....	171
Adjusting.....	171
Stopping.....	240
Sunroof.....	155
Supplemental Restraint System (SRS).....	46
Switches (Around the Steering Wheel).....	4, 5, 157

## T

Tachometer.....	104
Temperature.....	
High Temperature Indicator.....	94
Low Temperature Indicator.....	94
Outside Temperature Display.....	105
Temperature Sensor.....	105, 197
Time (Setting).....	124
Tools.....	318
Towing a Trailer.....	205
Towing Your Vehicle.....	
Emergency.....	362

<b>Transmission</b> .....	215, 219
Continuously Variable Transmission .....	215
Fluid .....	274
Gear Position Indicator.....	92
Manual.....	219
Number.....	368
Shift Lever Position Indicator .....	216
<b>Trip Meter</b> .....	107, 111
<b>TRIP/CLOCK Button</b> .....	106
<b>Troubleshooting</b> .....	317
Blown Fuse.....	348, 350, 353
Brake Pedal Vibrates .....	23
Buzzer Sounds When Opening Door .....	25
Emergency Towing .....	362
Engine Won't Start .....	329
Noise When Braking .....	25
Overheating.....	338
Puncture/Flat Tyre .....	319
Rear Door Won't Open .....	24
Shift Lever Won't Move .....	337
Warning Indicators .....	88
<b>Turn signals</b> .....	160
Indicators (Instrument Panel).....	96
<b>Tyres</b> .....	296
Air Pressure .....	366
Checking and Maintaining.....	296
Inspection.....	297
Puncture (Flat Tyre).....	319
Rotation .....	300
Spare Tyre .....	319, 366
Tyre Chains.....	301

Wear Indicators.....	298
Winter.....	301

## U

<b>Unlocking the Doors</b> .....	128
<b>Unlocking the Driver's Doors from the Inside</b> .....	135
<b>Utility Pocket</b> .....	188

## V

<b>Vanity Mirrors</b> .....	7
<b>Vehicle Identification Numbers</b> .....	368
<b>Vehicle Stability Assist (VSA)</b> .....	228
Off Button.....	229
OFF Indicator.....	95
System Indicator.....	95
<b>Ventilation</b> .....	191, 194
<b>Viscosity (Oil)</b> .....	266, 267, 366
<b>VSA (Vehicle Stability Assist)</b> .....	228

## W

<b>Warning Indicator On/Blinking</b> .....	340
<b>Warning Labels</b> .....	85
<b>Watts</b> .....	365
<b>Wear Indicators (Tyre)</b> .....	298
<b>Wheel Nut Wrench (Jack Handle)</b> .....	323
<b>Window Washers</b>	
Adding/Refilling Fluid .....	276
Switch .....	166

<b>Windows (Opening and Closing)</b> .....	151
<b>Windscreen</b>	
Cleaning .....	310, 312
Defrosting/Defogging .....	193, 196
Washer Fluid.....	276
Wiper Blades.....	294
Wipers and Washers .....	166
<b>Winter Tyres</b> .....	301
Tyre Chains.....	301
<b>Wipers and Washers</b> .....	166
Checking and Replacing Wiper Blades.....	294
<b>Worn Tyres</b> .....	296